



**CANDIDATE – PLEASE NOTE!**

PRINT your name on the line below and return this booklet with your answer sheet. Failure to do so may result in disqualification.

TEST CODE **01234010**

MAY/JUNE 2020

**FORM TP 2020091**

**CARIBBEAN EXAMINATIONS COUNCIL  
CARIBBEAN SECONDARY EDUCATION CERTIFICATE®  
EXAMINATION**

**MATHEMATICS**

**Paper 01 – General Proficiency**

*1 hour 30 minutes*

**13 MAY 2020 (p.m.)**

**READ THE FOLLOWING INSTRUCTIONS CAREFULLY.**

1. This test consists of 60 items. You will have 1 hour and 30 minutes to answer them.
2. In addition to this booklet, you should have an answer sheet.
3. **A list of formulae is provided on page 2 of this booklet.**
4. Each item in this test has four suggested answers lettered (A), (B), (C), (D). Read each item you are about to answer and decide which choice is best.
5. On your answer sheet, find the number which corresponds to your item and shade the space having the same letter as the answer you have chosen. Look at the sample item below.

Sample Item

$2a + 6a =$

- (A)  $8a$
- (B)  $8a^2$
- (C)  $12a$
- (D)  $12a^2$

Sample Answer



The best answer to this item is “ $8a$ ”, so (A) has been shaded.

6. If you want to change your answer, erase it completely before you fill in your new choice.
7. When you are told to begin, turn the page and work as quickly and as carefully as you can. If you cannot answer an item, go on to the next one. You may return to that item later.
8. You may do any rough work in this booklet.
9. Calculators and mathematical tables are NOT allowed for this paper.

**DO NOT TURN THIS PAGE UNTIL YOU ARE TOLD TO DO SO.**



**LIST OF FORMULAE**

Volume of a prism  $V = Ah$  where  $A$  is the area of the cross-section and  $h$  is the perpendicular length.

Volume of a cylinder  $V = \pi r^2 h$  where  $r$  is the radius of the base and  $h$  is the perpendicular height.

Volume of a right pyramid  $V = \frac{1}{3} Ah$  where  $A$  is the area of the base and  $h$  is the perpendicular height.

Circumference  $C = 2\pi r$  where  $r$  is the radius of the circle.

Arc length  $S = \frac{\theta}{360} \times 2\pi r$  where  $\theta$  is the angle subtended by the arc, measured in degrees.

Area of a circle  $A = \pi r^2$  where  $r$  is the radius of the circle.

Area of a sector  $A = \frac{\theta}{360} \times \pi r^2$  where  $\theta$  is the angle of the sector, measured in degrees.

Area of a trapezium  $A = \frac{1}{2} (a + b) h$  where  $a$  and  $b$  are the lengths of the parallel sides and  $h$  is the perpendicular distance between the parallel sides.

Roots of quadratic equations If  $ax^2 + bx + c = 0$ ,

$$\text{then } x = \frac{-b \pm \sqrt{b^2 - 4ac}}{2a}$$

Trigonometric ratios

$$\sin \theta = \frac{\text{length of opposite side}}{\text{length of hypotenuse}}$$

$$\cos \theta = \frac{\text{length of adjacent side}}{\text{length of hypotenuse}}$$

$$\tan \theta = \frac{\text{length of opposite side}}{\text{length of adjacent side}}$$

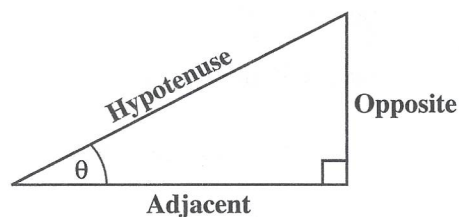

Area of a triangle

Area of  $\Delta = \frac{1}{2} bh$  where  $b$  is the length of the base and  $h$  is the perpendicular height.

$$\text{Area of } \Delta ABC = \frac{1}{2} ab \sin C$$

$$\text{Area of } \Delta ABC = \sqrt{s(s-a)(s-b)(s-c)}$$

$$\text{where } s = \frac{a+b+c}{2}$$

Sine rule

$$\frac{a}{\sin A} = \frac{b}{\sin B} = \frac{c}{\sin C}$$

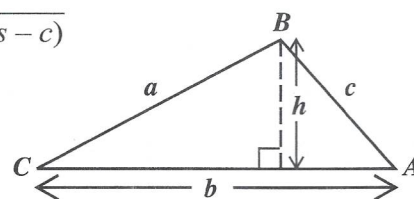

Cosine rule

$$a^2 = b^2 + c^2 - 2bc \cos A$$

GO ON TO THE NEXT PAGE

1.  $(-3)^2 + (-2)^2$  is equal to

- (A) -13
- (B) -10
- (C) 5
- (D) 13

2. What is the value of the digit 2 in the number 48.621?

- (A)  $\frac{2}{100}$
- (B)  $\frac{2}{10}$
- (C) 2
- (D) 200

3. Using the distributive property

$$49 \times 17 + 49 \times 3 =$$

- (A)  $49 \times 20$
- (B)  $49 + 20$
- (C)  $52 \times 66$
- (D)  $52 + 66$

4. A total of 540 beads are shared in the ratio 4:5. The LARGER share of beads is

- (A) 60
- (B) 240
- (C) 300
- (D) 432

5. 0.45 written as a common fraction, in its simplest form, is

- (A)  $\frac{9}{20}$
- (B)  $\frac{4}{5}$
- (C)  $\frac{9}{10}$
- (D)  $\frac{5}{4}$

6. Dan sold 40 concert tickets in 5 days. Each day he sold 3 tickets MORE than the previous day. The number of tickets he sold on the third day is

- (A) 8
- (B) 9
- (C) 10
- (D) 11

Item 7 refers to the following Venn diagram which shows the number of members of a sports club who play rugby or basketball.

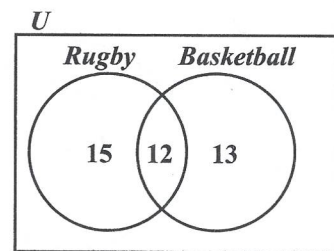

7. The number of members who play rugby but NOT basketball is

- (A) 12
- (B) 15
- (C) 28
- (D) 40

GO ON TO THE NEXT PAGE

Item 8 refers to the following Venn diagram.

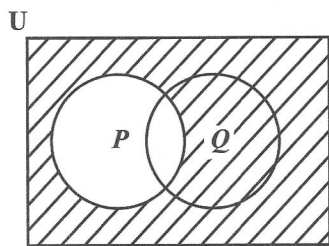

8. The shaded region represents

- (A)  $P'$
- (B)  $(P \cup Q)'$
- (C)  $P \cup Q'$
- (D)  $Q \cap P'$

Items 9–10 refer to the following Venn diagram which shows the universal set ( $U$ ), and two sets,  $T$  and  $C$ , that represent the students in a class who play tennis ( $T$ ) and chess ( $C$ ).

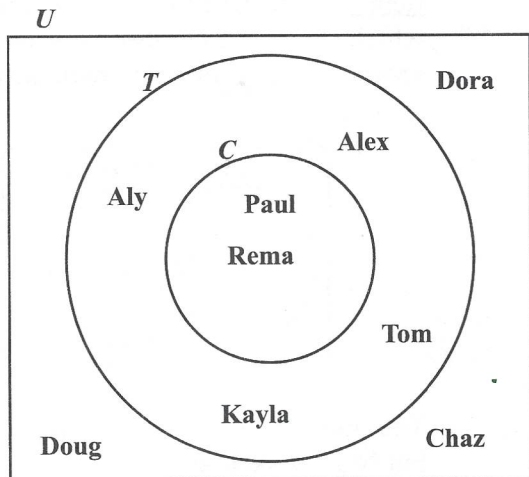

9. How many students play BOTH games?

- (A) 2
- (B) 3
- (C) 4
- (D) 6

10. How many students play EXACTLY one game?

- (A) 2
- (B) 3
- (C) 4
- (D) 6

Item 11 refers to the following information on the description of 3 sets.

- $P = \{\text{prime numbers}\}$
- $Q = \{\text{odd numbers}\}$
- $R = \{\text{even numbers}\}$

11. Which of the following sets is empty?

- (A)  $P \cap R$
- (B)  $P \cup Q$
- (C)  $P \cap Q$
- (D)  $Q \cap R$

12. If  $n(A) = 14$ ,  $n(B) = 15$ , and  $n(A \cap B) = 6$ , then  $n(A \cup B)$  is

- (A) 2
- (B) 19
- (C) 23
- (D) 29

13. A dress which costs \$180 is being sold at a discount of 10%. The amount of the discount is

- (A) \$ 1.80
- (B) \$ 10.00
- (C) \$ 18.00
- (D) \$170.00



14. A dinner at a restaurant was advertised at \$60 plus 18% tax. The total bill for this dinner was
- (A) \$60.00
  - (B) \$70.80
  - (C) \$78.00
  - (D) \$81.60
15. The cost price of a refrigerator is \$1 850.00. A buyer who is given a discount of 5% for a cash purchase will pay
- (A) \$1 942.50
  - (B) \$1 845.00
  - (C) \$1 757.50
  - (D) \$ 1350.00
16. The annual interest rate on a mortgage on a house assessed at a value of \$450 000 is 5 cents on every \$1. What is the interest paid on the mortgage for the first year?
- (A) \$ 11 750
  - (B) \$ 22 500
  - (C) \$107 500
  - (D) \$117 500
17. The simple interest on a sum of money invested at 5% per annum for 3 years was \$90.
- The sum of money invested was
- (A) \$ 54
  - (B) \$ 150
  - (C) \$ 600
  - (D) \$1350
18. At the end of any year a car is worth 5% less than what it was worth at the beginning of the year. If a car is worth \$9 500 in December 2016, then its value in January 2016 was
- (A) \$ 9 025
  - (B) \$ 9 995
  - (C) \$10 000
  - (D) \$10 025
19. A television set costs \$350 cash. When bought on hire purchase, a deposit of \$35 is required, followed by 12 monthly payments of \$30 each. How much is saved by paying cash?
- (A) \$10
  - (B) \$25
  - (C) \$40
  - (D) \$45
20. A man's regular pay is \$3 per hour up to 40 hours. Overtime is twice the payment for regular time. If he was paid \$216, how many hours of overtime did he work?
- (A) 8
  - (B) 16
  - (C) 28
  - (D) 48
21.  $3x - 4(x + 6) =$
- (A)  $-x + 6$
  - (B)  $-x - 24$
  - (C)  $-7x + 6$
  - (D)  $-7x - 24$



22. If  $5(2x - 1) = 35$ , then  $x =$
- (A)  $-4$   
(B)  $\frac{1}{4}$   
(C)  $3$   
(D)  $4$
23. If  $x$  is an integer that satisfies the inequality  $4 < 2x \leq 6$ , then
- (A)  $2 < x \leq 3$   
(B)  $2 < x \leq 6$   
(C)  $4 < x \leq 3$   
(D)  $4 < x \leq 6$
24. Given that  $3 * 6 = 12$  and  $2 * 5 = 9$ , then  $a * b$  may be defined as
- (A)  $4(b - a)$   
(B)  $a^2 - b$   
(C)  $6a - b$   
(D)  $2a + b$
25. If  $p + q = -1$  and  $pq = -6$ , then  $p^3 + q^3 =$
- (A)  $-19$   
(B)  $-13$   
(C)  $25$   
(D)  $35$

26. The distance  $L$  that an elastic string is stretched by hanging an object of mass  $m$  varies directly as the mass of that object. If a 5-kg object stretches the string 31 cm, how far will a 29-kg object stretch the string?
- (A) 4.68 cm  
(B) 6.2 cm  
(C) 135.72 cm  
(D) 179.8 cm

27. Given that  $A = \begin{bmatrix} 1 & 3 & -3 \\ 3 & 0 & 5 \end{bmatrix}$ , then  $3A$  equals
- (A)  $\begin{bmatrix} 3 & 9 & -9 \\ 9 & 0 & 15 \end{bmatrix}$   
(B)  $\begin{bmatrix} 4 & 6 & -6 \\ 6 & 3 & 8 \end{bmatrix}$   
(C)  $\begin{bmatrix} 3 & 9 & -6 \\ 9 & 0 & 15 \end{bmatrix}$   
(D)  $\begin{bmatrix} -2 & 0 & 6 \\ 0 & 3 & 2 \end{bmatrix}$

Item 28 refers to the following matrix,  $P$ .

$$P = \begin{bmatrix} 8 & 6 \\ 7 & 5 \end{bmatrix}$$

28. The determinant of  $P$ ,  $|P|$ , is
- (A) 2  
(B)  $-2$   
(C)  $-13$   
(D) 26

Item 29 refers to the following vectors,  $\mathbf{p}$  and  $\mathbf{q}$ .

$$\mathbf{p} = \begin{pmatrix} 3 \\ 7 \end{pmatrix} \quad \mathbf{q} = \begin{pmatrix} -2 \\ 5 \end{pmatrix}$$

29. The vector  $\mathbf{p} - \mathbf{q}$  is represented by

(A),  $\begin{pmatrix} 1 \\ 12 \end{pmatrix}$

(B)  $\begin{pmatrix} 5 \\ 12 \end{pmatrix}$

(C)  $\begin{pmatrix} 5 \\ 2 \end{pmatrix}$

(D)  $\begin{pmatrix} 1 \\ 5 \end{pmatrix}$

Item 30 refers to the following diagram of triangle  $PQR$ , in which  $L$  is the midpoint of  $PR$  and  $\vec{QP} = \mathbf{a}$  and  $\vec{QR} = \mathbf{b}$ .

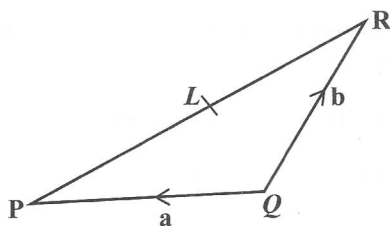

30.  $\vec{PL}$  expressed in terms of  $\mathbf{a}$  and  $\mathbf{b}$  is

(A)  $\frac{(\mathbf{a} + \mathbf{b})}{2}$

(B)  $\frac{(\mathbf{b} - \mathbf{a})}{2}$

(C)  $\frac{(-\mathbf{b} - \mathbf{a})}{2}$

(D)  $\frac{(\mathbf{a} - \mathbf{b})}{2}$

31. The length 3 800 millimetres expressed in metres is

(A) 0.38

(B) 3.8

(C) 38

(D) 380

32. The volume of a cube with edge 10 cm is

(A)  $30 \text{ cm}^3$

(B)  $100 \text{ cm}^3$

(C)  $300 \text{ cm}^3$

(D)  $1\,000 \text{ cm}^3$

33. The distance around the edge of a circular pond is 88 metres. The radius, in metres, is

(A)  $88\pi$

(B)  $176\pi$

(C)  $\frac{88}{\pi}$

(D)  $\frac{88}{2\pi}$

Item 34 refers to the following diagram, **not drawn to scale**, which shows a cylinder of radius 3 cm and height 8 cm.

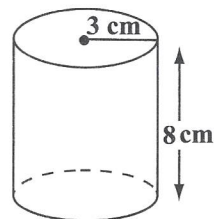

34. The volume of the cylinder is

(A)  $12 \pi \text{ cm}^3$

(B)  $48 \pi \text{ cm}^3$

(C)  $72 \pi \text{ cm}^3$

(D)  $192 \pi \text{ cm}^3$

Item 35 refers to the following diagram, **not drawn to scale**, which shows a sector of a circle with centre  $O$ .

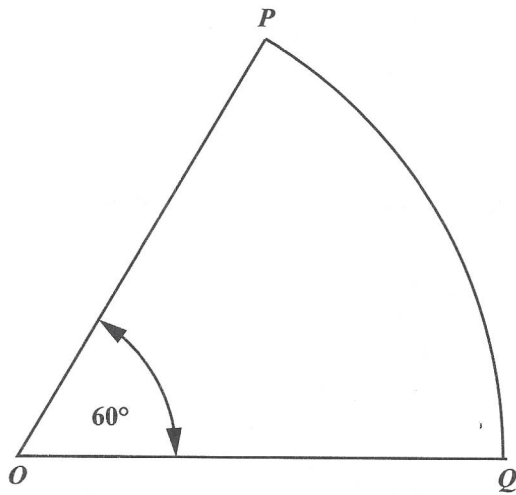

35. If the length of the minor arc  $PQ$  is 8 cm, what is the circumference of the circle?

- (A) 16 cm
- (B) 24 cm
- (C) 48 cm
- (D) 64 cm

36. A man leaves home at 22:15 hours and reaches his destination at 04:00 hours on the following day in the same time zone. How many hours did the journey take?

- (A) 5
- (B)  $5\frac{3}{4}$
- (C) 6
- (D)  $6\frac{1}{4}$

---

Item 37 refers to the following diagram which shows a square,  $A$ , and a rectangle,  $B$ .

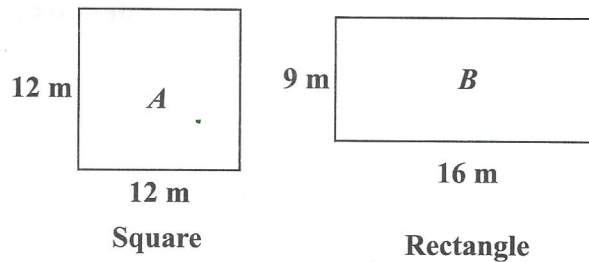

37. Which of the following statements is true about the perimeters of the figures  $A$  and  $B$ ?

- (A) Perimeter of  $A$  = perimeter of  $B$
- (B) Perimeter of  $A$  < perimeter of  $B$
- (C) Perimeter of  $A$   $\geq$  perimeter of  $B$
- (D) Perimeter of  $A$  > perimeter of  $B$



Item 38 refers to the following diagram, not drawn to scale, which consists of a triangle resting on a square of side 5 cm.

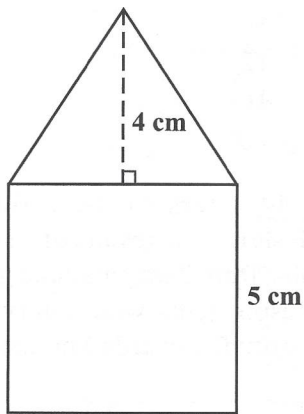

38. If the height of the triangle is 4 cm, what is the TOTAL area of the figure?
- (A) 35 cm<sup>2</sup>
  - (B) 45 cm<sup>2</sup>
  - (C) 50 cm<sup>2</sup>
  - (D) 100 cm<sup>2</sup>

Items 39–40 refer to the following histogram which shows the number of children aged 4, 5, 6, 7 and 8 who took part in a survey.

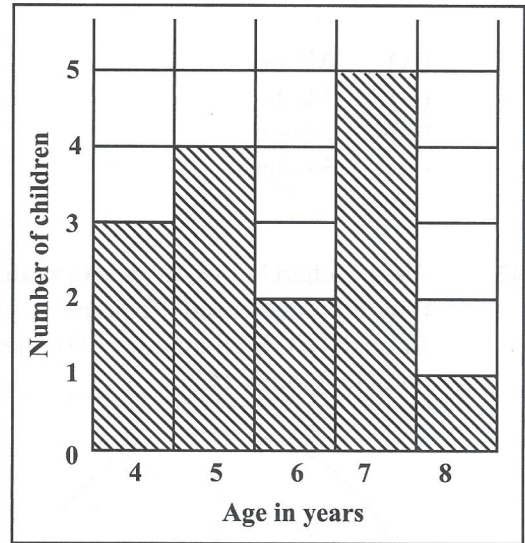

39. What was the modal age?
- (A) 5
  - (B) 6
  - (C) 7
  - (D) 8
40. How many children took part in the survey?
- (A) 5
  - (B) 15
  - (C) 75
  - (D) 87

41. Ms Clarke arranged the 15 test scores of her students in order of size and selected the 8th score for reporting purposes. Which of the following statistical measures did Ms Clarke obtain?

- (A) Mean
- (B) Mode
- (C) Range
- (D) Median

42. The pie chart below, **drawn to scale**, shows how a student used 12 hours in studying English (*E*), Mathematics (*M*), French (*F*) and Geography (*G*).

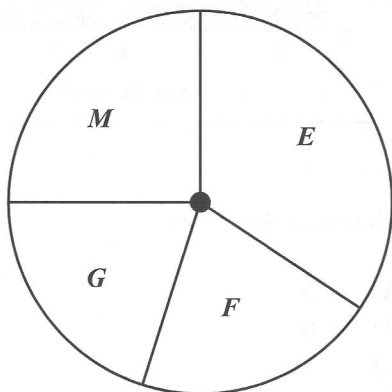

The amount of time spent studying Mathematics is APPROXIMATELY

- (A) 1 hour
- (B) 2 hours
- (C) 3 hours
- (D) 4 hours

43. If the mean of the 4 numbers 4, 8,  $x$  and 12 is 10, then  $x$  is

- (A) 4
- (B) 10
- (C) 12
- (D) 16

Item 44 refers to the following table which shows the results of a survey of 100 persons, from 2 major ethnic groups, *P* and *R*. Respondents were interviewed about their attitude towards Mathematics.

Attitude Towards Mathematics	Ethnicity		Total
	<i>P</i>	<i>R</i>	
Positive	25	12	37
Neutral	11	9	20
Negative	24	19	43
Total	60	40	100

44. A respondent is selected at random. What is the probability that he has a positive attitude towards Mathematics?

- (A) 0.20
- (B) 0.37
- (C) 0.43
- (D) 0.60

GO ON TO THE NEXT PAGE

45. Which of the following diagrams BEST illustrates a function?

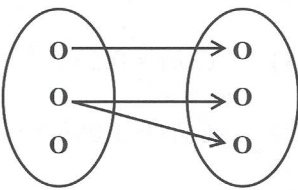
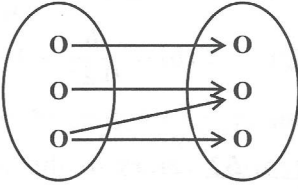
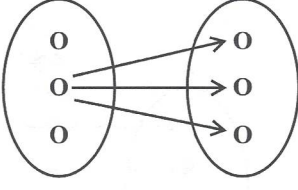
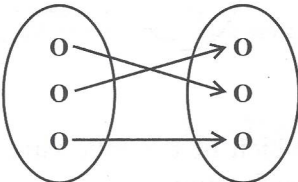
- (A) 
- (B) 
- (C) 
- (D) 

Item 46 refers to the following graph of a straight line.

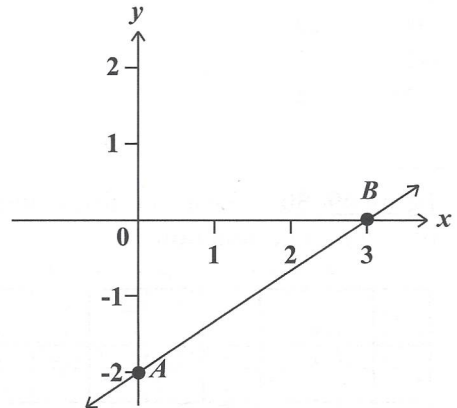

46. The straight line  $AB$  cuts the  $y$ -axis at

- (A)  $(0, 3)$   
(B)  $(0, 2)$   
(C)  $(3, -2)$   
(D)  $(0, -2)$

Item 47 refers to the following graph of a straight line.

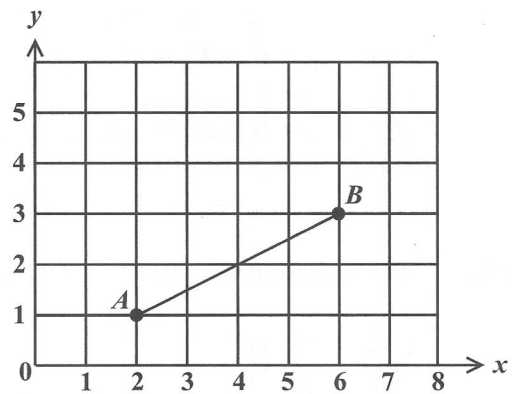

47. The gradient of  $AB$  in the graph above is

- (A)  $-\frac{1}{2}$   
(B)  $\frac{1}{2}$   
(C)  $-2$   
(D)  $2$

GO ON TO THE NEXT PAGE

48. If  $f(x) = 2x^2 - 1$ , then  $f(-3) =$
- (A) -32
  - (B) -19
  - (C) 17
  - (D) 35

Items 49–50 refer to the following graph of a quadratic function.

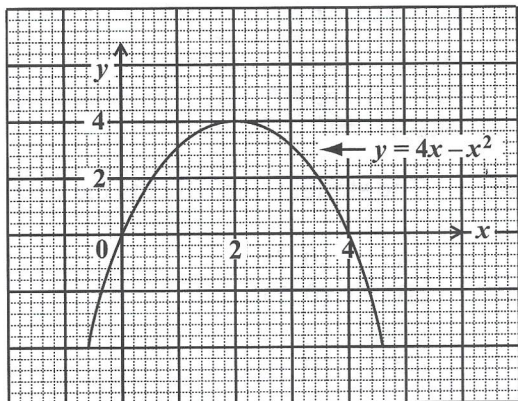

49. The values of  $x$  at the points where the curve  $y = 4x - x^2$  intersects the line  $y = 0$  are
- (A)  $x = 0$  and  $x = 4$
  - (B)  $x = 0$  and  $x = 2$
  - (C)  $x = 0$  and  $x = -4$
  - (D)  $x = 2$  and  $x = 4$

50. The maximum point of  $y = 4x - x^2$  is
- (A) (4, 4)
  - (B) (0, 4)
  - (C) (4, 2)
  - (D) (2, 4)

51. A parking lot charges \$1.00 plus \$0.25 for every hour ( $h$ ) or part thereof in which a vehicle is parked. A function,  $C(h)$ , that represents the parking cost is

- (A)  $C(h) = 0.25h$
- (B)  $C(h) = 1.00h + 0.25$
- (C)  $C(h) = 0.25h + 1.00$
- (D)  $C(h) = \frac{h}{0.25} + 1.00$

Item 52 refers to the following arrow diagram which shows a function,  $f$ .

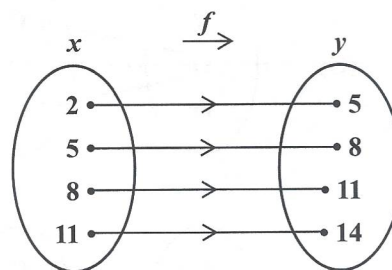

52. Which of the following BEST describes the function?
- (A)  $y = x + 3$
  - (B)  $x + y = 3$
  - (C)  $x = y + 3$
  - (D)  $y = 2x + 1$

53. If the sum of the interior angles of a polygon is 4 right angles, then the polygon is a
- (A) triangle
  - (B) hexagon
  - (C) pentagon
  - (D) quadrilateral

GO ON TO THE NEXT PAGE

Item 54 refers to the following diagram of a right-angled triangle.

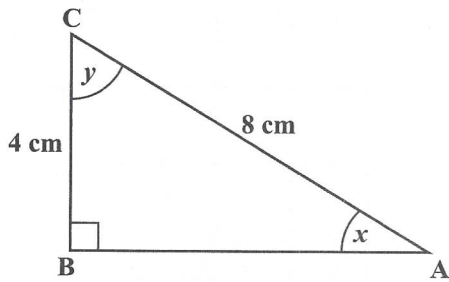

54. In the right-angled triangle above, which trigonometric ratio is equal to  $\frac{4}{8}$ ?
- (A)  $\sin x$
  - (B)  $\tan y$
  - (C)  $\sin y$
  - (D)  $\tan x$

Item 55 refers to the following diagram of an isosceles triangle.

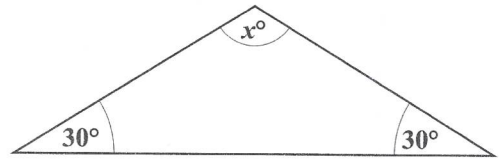

55. In the triangle, the value of  $x$  is
- (A)  $30^\circ$
  - (B)  $60^\circ$
  - (C)  $120^\circ$
  - (D)  $150^\circ$

Item 56 refers to the following diagram which shows a transformation that maps  $\triangle OPQ$  into  $\triangle OP'Q'$ .

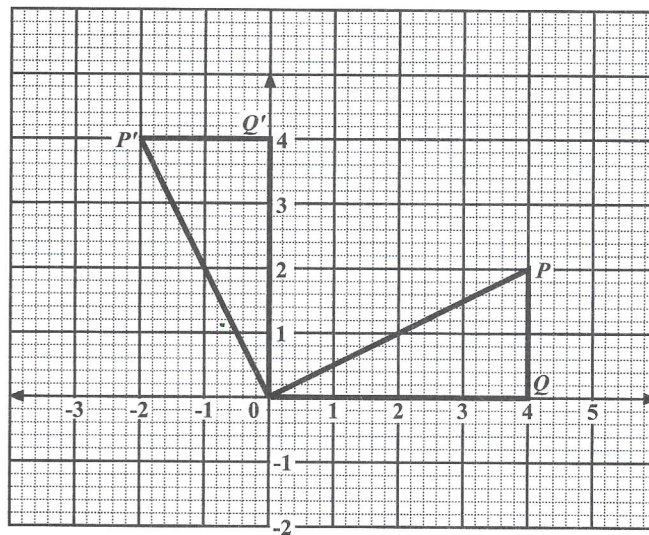

56. The type of transformation that has taken place is a
- (A) rotation of  $90^\circ$  about the origin
  - (B) rotation of  $-90^\circ$  about the origin
  - (C) reflection in the line  $y = x$
  - (D) reflection in the origin



Item 57 refers to the following diagram which shows a transformation.

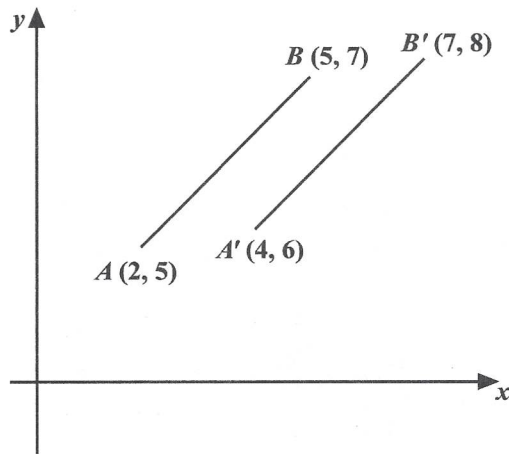

57. In the diagram, the translation by which  $AB$  is mapped onto  $A'B'$  is represented by

- (A)  $\begin{pmatrix} 1 \\ 1 \end{pmatrix}$
- (B)  $\begin{pmatrix} 2 \\ 1 \end{pmatrix}$
- (C)  $\begin{pmatrix} 3 \\ 2 \end{pmatrix}$
- (D)  $\begin{pmatrix} 5 \\ 3 \end{pmatrix}$

Item 58 refers to the following diagram which shows a transformation.

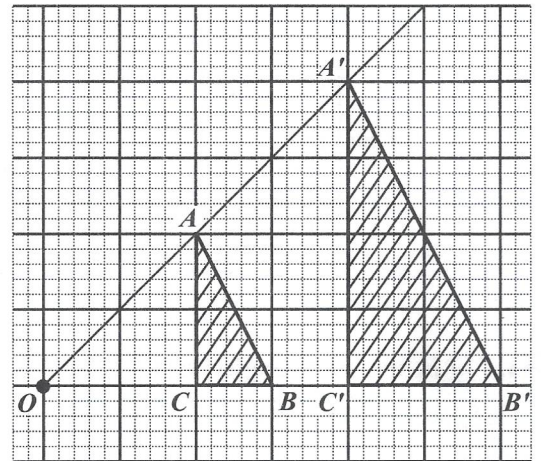

58.  $OAA'$ ,  $OBB'$  and  $OCC'$  are straight lines.  $\triangle ABC$  is mapped onto  $\triangle A'B'C'$  by an enlargement with centre  $O$ . What is the scale factor of the enlargement?

- (A)  $-2$
- (B)  $-\frac{1}{2}$
- (C)  $\frac{1}{2}$
- (D)  $2$

Item 59 refers to the following pair of similar triangles.

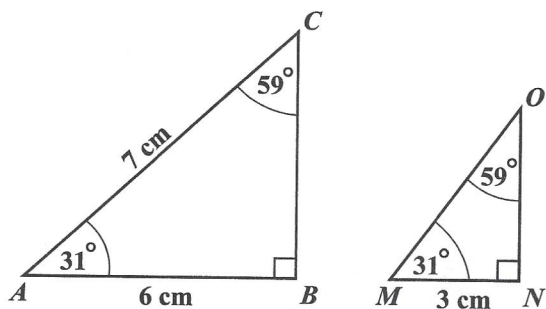

59. The length of  $MO$ , in centimetres, is

- (A) 2.5
- (B) 3.0
- (C) 3.5
- (D) 7.0

Item 60 refers to the following diagram.

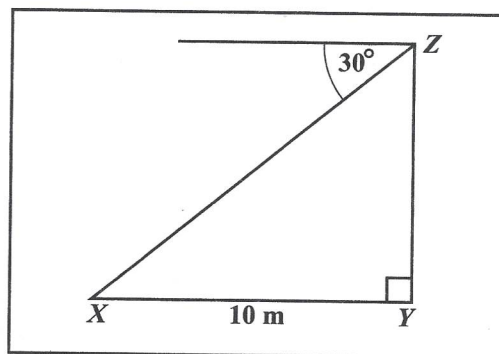

60. The diagram above, **not drawn to scale**, shows that the angle of depression of a point  $X$  from  $Z$  is  $30^\circ$ . If  $X$  is 10 metres from  $Y$ , the height of  $YZ$ , in metres, is

- (A)  $10 \tan 30^\circ$
- (B)  $10 \sin 30^\circ$
- (C)  $10 \cos 30^\circ$
- (D)  $10 \cos 60^\circ$

END OF TEST

IF YOU FINISH BEFORE TIME IS CALLED, CHECK YOUR WORK ON THIS TEST.

**CANDIDATE'S RECEIPT**

**INSTRUCTIONS TO CANDIDATE:**

1. Fill in all the information requested clearly in capital letters.

TEST CODE: 

0	1	2	3	4	0	1	0
---	---	---	---	---	---	---	---

SUBJECT: MATHEMATICS – Paper 01

PROFICIENCY: GENERAL

REGISTRATION NUMBER: 

--	--	--	--	--	--	--	--	--	--

FULL NAME: \_\_\_\_\_  
(BLOCK LETTERS)

Signature: \_\_\_\_\_

Date: \_\_\_\_\_

2. Ensure that this slip is detached by the Supervisor or Invigilator and given to you when you hand in this booklet.
3. Keep it in a safe place until you have received your results.

**INSTRUCTION TO SUPERVISOR/INVIGILATOR:**

Sign the declaration below, detach this slip and hand it to the candidate as his/her receipt for this booklet collected by you.

I hereby acknowledge receipt of the candidate's booklet for the examination stated above.

Signature: \_\_\_\_\_  
Supervisor/Invigilator

Date: \_\_\_\_\_

