

**CARIBBEAN EXAMINATIONS COUNCIL****SECONDARY EDUCATION CERTIFICATE  
EXAMINATION****MATHEMATICS****Paper 01 – General Proficiency***90 minutes***READ THE FOLLOWING DIRECTIONS CAREFULLY**

- In addition to this test booklet, you should have an answer sheet.
- Each item in this test has four suggested answers, lettered (A), (B), (C), (D). Read each item you are about to answer, and decide which choice is best.
- On your answer sheet, find the number which corresponds to your item and blacken the space having the same letter as the answer you have chosen. Look at the sample item below.

Sample Item

$2a + 6a =$

- (A)  $8a$   
 (B)  $8a^2$   
 (C)  $12a$   
 (D)  $12a^2$

Sample Answer

The best answer to this item is "8a", so answer space A has been blackened.

- If you want to change your answer, be sure to erase your old answer completely and fill in your new choice.
- When you are told to begin, turn the page and work as quickly and as carefully as you can. If you cannot answer an item, omit it and go on to the next one. You can return later to the item omitted. Your score will be the total number of correct answers.
- You may do any rough work in the booklet.
- Figures are not necessarily drawn to scale.
- All numbers are real numbers. For calculations that involve  $\pi$ , use  $\pi = \frac{22}{7}$ .
- This test consists of 60 items. You will have 90 minutes to answer them.
- Do not be concerned that the answer sheet provides spaces for more answers than there are items in this test.
- Calculators, slide rules and mathematical tables may NOT be used for this paper.

**DO NOT TURN THIS PAGE UNTIL YOU ARE TOLD TO DO SO**

1. The number 3.14063 correct to 3 decimal places is
- (A) 3.140  
(B) 3.141  
(C) 3.146  
(D) 3.150
2. The set of factors of 18 is
- (A) {1, 18}  
(B) {2, 3, 6, 9}  
(C) {1, 2, 3, 6, 9, 18}  
(D) {18, 36, 54, ...}
3. Which of the following is the same as  $57 \times 999$ ?
- (A)  $57 \times 100 - 1$   
(B)  $57(100 - 1)$   
(C)  $57 \times 1000 - 1$   
(D)  $57(1000 - 1)$
4. A line which has a gradient of  $\frac{1}{3}$  passes through the point (0, 2). An equation of the line is
- (A)  $y = \frac{1}{3}x$   
(B)  $y = \frac{1}{3}x + 2$   
(C)  $y = 3x$   
(D)  $y = 3x + 2$
5. A boat was travelling on a bearing of  $270^\circ$ . In what direction was it travelling?
- (A) West  
(B) East  
(C) North  
(D) South
6. The exchange rate for one United States dollar (US \$1.00) is two dollars and seventy cents in Eastern Caribbean currency (EC \$2.70). The value of US \$4.50 in EC currency is
- (A) \$ 1.67  
(B) \$ 6.00  
(C) \$ 7.20  
(D) \$12.15
7.  $\{x : 5 \leq x < 10, x \text{ is an integer}\}$  may be listed as
- (A) (5, 10)  
(B) {6, 7, 8, 9}  
(C) [5, 6, 7, 8, 9]  
(D) {5, 6, 7, 8, 9, 10}
8.  $P = \{\text{factors of 15}\}$  and  $Q = \{\text{factors of 20}\}$ . The HCF of 15 and 20 can be described as the set
- (A)  $P$   
(B)  $Q$   
(C)  $P \cup Q$   
(D)  $P \cap Q$
- |   |   |   |
|---|---|---|
| 1 | → | 3 |
| 2 | → | 5 |
| 3 | → | 7 |
| 4 | → | 9 |
9. Which of the following could describe the mapping above?
- (A)  $f: x \rightarrow x + 3$   
(B)  $f: x \rightarrow 2x + 1$   
(C)  $f: x \rightarrow x^2 + 1$   
(D)  $f: x \rightarrow 2x^2 - 3$

GO ON TO THE NEXT PAGE

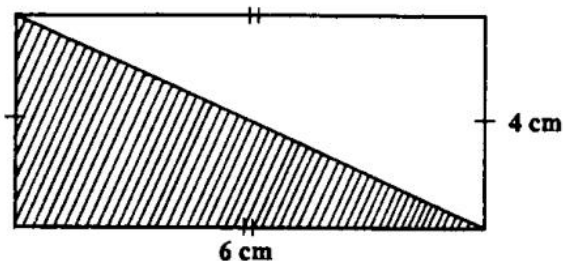

10. The area of the shaded part of the rectangle above is

- (A)  $(6 + 4) \text{ cm}^2$   
 (B)  $\frac{(6 \times 4)}{2} \text{ cm}^2$   
 (C)  $(4 + 6 + 4 + 6) \text{ cm}^2$   
 (D)  $(6 \times 4) \text{ cm}^2$

11.  $\frac{6p}{5q} + \frac{4r}{3s} =$

- (A)  $\frac{10pr}{8qs}$   
 (B)  $\frac{24pr}{8qs}$   
 (C)  $\frac{6ps + 4qr}{15qs}$   
 (D)  $\frac{18ps + 20qr}{15qs}$

12. If the number  $x$  is such that  $60 < x < 80$ , then  $\sqrt{x}$  lies between

- (A) 7 and 8  
 (B) 7 and 9  
 (C) 8 and 9  
 (D) 8 and 10

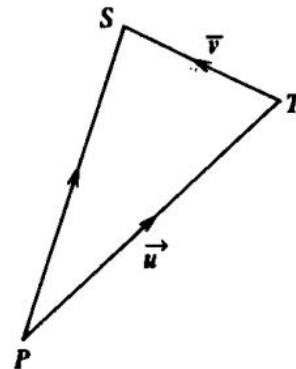

13. In the diagram above, if  $\mathbf{u}$  is the vector  $\begin{pmatrix} 4 \\ 3 \end{pmatrix}$  and  $\mathbf{v}$  is the vector  $\begin{pmatrix} -2 \\ 1 \end{pmatrix}$ , then  $PS$  is

- (A)  $\begin{pmatrix} 2 \\ 2 \end{pmatrix}$   
 (B)  $\begin{pmatrix} 2 \\ 4 \end{pmatrix}$   
 (C)  $\begin{pmatrix} 6 \\ 2 \end{pmatrix}$   
 (D)  $\begin{pmatrix} 6 \\ 4 \end{pmatrix}$

14. Expressed in standard form,  $0.003\ 68 =$

- (A)  $3.68 \times 10^3$   
 (B)  $3.68 \times 10^2$   
 (C)  $3.68 \times 10^{-2}$   
 (D)  $3.68 \times 10^{-3}$

15.  $5(2x - y) - 2(3y - 5x) =$

- (A)  $-11y$   
 (B)  $2x - 6y$   
 (C)  $5x - 7y$   
 (D)  $20x - 11y$

16. If  $60 - y < 20$ , then a possible value of  $y$  is

- (A) 10  
 (B) 30  
 (C) 40  
 (D) 50

GO ON TO THE NEXT PAGE

17.  $A = \begin{pmatrix} 2 & 1 \\ 0 & -1 \end{pmatrix}$ ,  $B = \begin{pmatrix} 0 & -2 \\ 3 & 1 \end{pmatrix}$ .

Then  $AB =$

(A)  $\begin{pmatrix} 3 & -3 \\ -3 & -1 \end{pmatrix}$

(B)  $\begin{pmatrix} 3 & -1 \\ 3 & 0 \end{pmatrix}$

(C)  $\begin{pmatrix} 0 & 2 \\ 6 & 2 \end{pmatrix}$

(D)  $\begin{pmatrix} 0 & -2 \\ 0 & -1 \end{pmatrix}$

18. A company gives a 10% discount off the marked price of items. A government sales tax of 8% is charged on the sale price. What would a customer pay for an article marked \$5000?

(A) \$4860

(B) \$4900

(C) \$4960

(D) \$5060

19.  $6x^2 + 5x - 4$  is equivalent to

(A)  $(6x - 2)(x + 2)$

(B)  $(6x + 2)(x - 2)$

(C)  $(3x + 4)(2x - 1)$

(D)  $(3x - 4)(2x + 1)$

20. Classes in school start at 08:50 hrs. and end at 15:00 hrs. There is a 20-minute morning break and a midday break for 1 hr. How much time is spent in class?

(A) 2 h 30 min

(B) 4 h 50 min

(C) 5 h 30 min

(D) 6 h 10 min

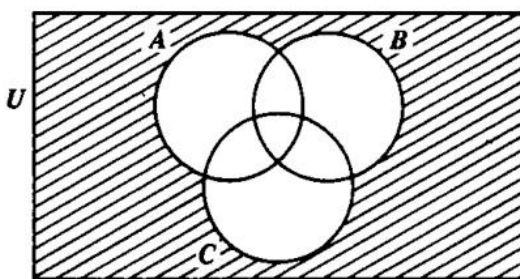

21. In the Venn diagram above, the shaded region represents the set

(A)  $A \cap (B \cap C)'$

(B)  $(A \cup B)' \cup C$

(C)  $(A \cap B \cap C)'$

(D)  $(A \cup B \cup C)'$

22. There are 9000 children in a town. The probability that a child is affected by an epidemic is  $\frac{1}{3}$ . How many children are NOT likely to be affected?

(A) 2700

(B) 3000

(C) 6000

(D) 6300

23.  $2(a^2b)^3 =$

(A)  $2a^5b^3$

(B)  $2a^6b^3$

(C)  $6a^2b$

(D)  $8a^6b^3$

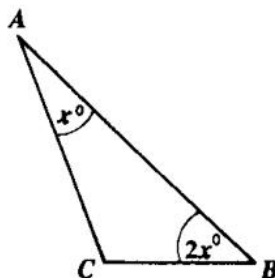

24. In the triangle  $ABC$  above, not drawn to scale, angle  $A = x^\circ$  and angle  $B = 2x^\circ$ . If angle  $C$  is less than  $120^\circ$ , then angle  $A$  is

(A) less than  $20^\circ$

(B) exactly  $60^\circ$

(C) between  $20^\circ$  and  $60^\circ$

(D) between  $60^\circ$  and  $120^\circ$

GO ON TO THE NEXT PAGE

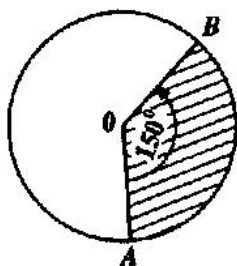

25. The area of the circle above, not drawn to scale, is  $27 \text{ cm}^2$ . What is the area of the shaded sector?
- (A)  $11.25 \text{ cm}^2$   
 (B)  $13.50 \text{ cm}^2$   
 (C)  $14.00 \text{ cm}^2$   
 (D)  $22.50 \text{ cm}^2$

Items 26 - 28 refer to the graph below.

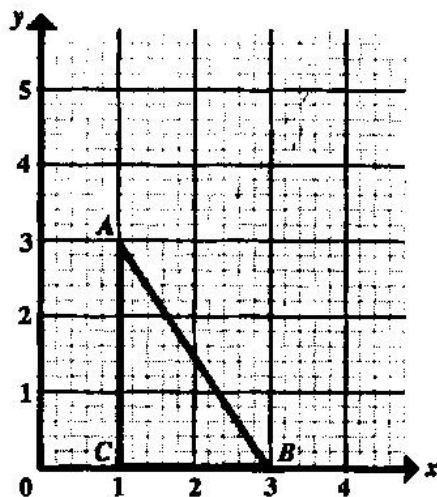

26. The coordinates of the point A are
- (A) (3, 0)  
 (B) (3, 1)  
 (C) (0, 3)  
 (D) (1, 3)
27. The gradient of AB is
- (A)  $-\frac{3}{2}$   
 (B)  $-\frac{2}{3}$   
 (C)  $\frac{2}{3}$   
 (D)  $\frac{3}{2}$
28. The equation of the line CB is
- (A)  $y = 0$   
 (B)  $x = 0$   
 (C)  $x = 3$   
 (D)  $y = 3x$

29. Which of the following represents the statement, 'The difference of two square numbers is positive'?

- (A)  $2x - 2y > 0$   
 (B)  $2(y - x) > 0$   
 (C)  $x^2 - y^2 > 0$   
 (D)  $(y - x)^2 > 0$

30. Given that  $x = -3$ , what is the value of  $2x^2 - x + 5$ ?

- (A) 20  
 (B) 26  
 (C) 38  
 (D) 44

31. The simple interest on \$560 for  $2\frac{1}{2}$  years is \$98. The rate per cent per annum is

- (A) 6  
 (B) 7  
 (C) 8  
 (D) 12

32. The mean of 11 numbers is 7. One of the numbers, 13, is deleted. What is the mean of the remaining 10 numbers?

- (A) 7.7  
 (B) 6.4  
 (C) 6.0  
 (D) 5.8

33. A car presently valued at \$12 000 depreciates at the rate of 10% per annum. What will be its value one year later?

- (A) \$10 800  
 (B) \$11 800  
 (C) \$11 880  
 (D) \$11 990

GO ON TO THE NEXT PAGE

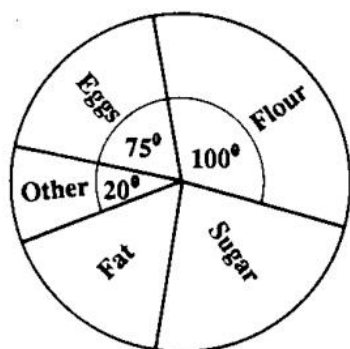

34. The pie chart above, not drawn to scale, represents the masses of ingredients in a cake. The total mass is 288 g. What is the combined mass (in grams) of fat and sugar?

- (A) 93
- (B) 132
- (C) 165
- (D) 195

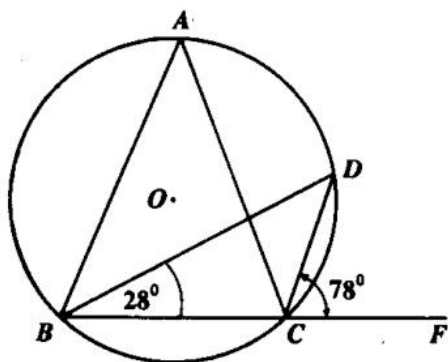

35. In the circle  $ABCD$  above,  $O$  is the centre, angle  $CBD$  is  $28^\circ$  and angle  $FCD$  is  $78^\circ$ . Angle  $BAC =$

- (A)  $28^\circ$
- (B)  $50^\circ$
- (C)  $74^\circ$
- (D)  $78^\circ$

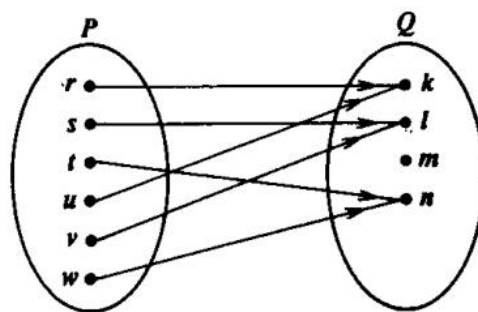

36. The relationship that BEST describes the mapping in the diagram above is

- (A) one-to-one
- (B) one-to-many
- (C) many-to-one
- (D) many-to-many

37. The translation  $T$  maps  $P(2, 3)$  onto  $P'(5, -1)$ . What is the image of  $Q(0, 4)$  under the translation  $T$ ?

- (A)  $(0, -16)$
- (B)  $(7, -4)$
- (C)  $(3, 0)$
- (D)  $(3, 8)$

38. A box contains 28 kg of potatoes. If 10.5 kg are sold, what percentage of the potatoes is left?

- (A) 17.5
- (B) 37.5
- (C) 62.5
- (D) 66.0

39. The sides of a parallelogram are 12 cm and 5 cm. If one of its diagonals is 13 cm, then its area is

- (A)  $30 \text{ cm}^2$
- (B)  $60 \text{ cm}^2$
- (C)  $65 \text{ cm}^2$
- (D)  $78 \text{ cm}^2$

40. The score which occurs most frequently in a distribution is the

- (A) median
- (B) mean deviation
- (C) standard deviation
- (D) mode

GO ON TO THE NEXT PAGE

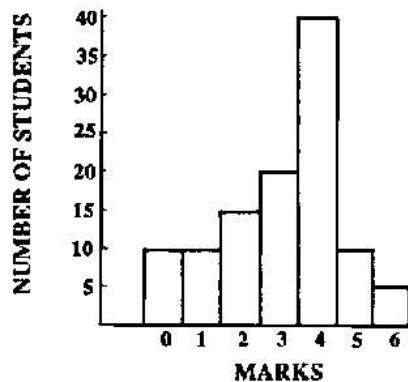

41. The histogram above shows the scores obtained by students in a Mathematics test marked out of 6.

How many students sat the test?

- (A) 40
- (B) 100
- (C) 110
- (D) 180

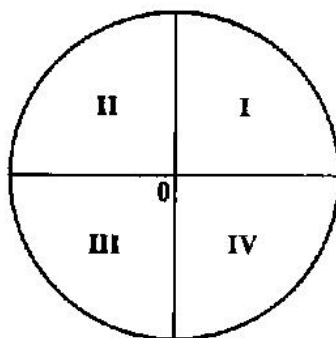

42. In which quadrant(s) above would  $\sin \theta$  have a positive value?

- (A) I only
- (B) I and II only
- (C) I and III only
- (D) II and IV only

43. If John's present age is  $3x$  years and Jane is twice his age, what will be the sum of their ages in 5 years' time?

- (A)  $3x + 10$
- (B)  $9x + 10$
- (C)  $9x + 15$
- (D)  $18x + 5$

44. A rectangular field is  $4x$  metres long and  $2x$  metres wide. Its perimeter is 288 metres. The value of  $x$  is

- (A) 24 m
- (B) 33 m
- (C) 36 m
- (D) 48 m

45. If  $E = \frac{1}{2}mv^2$ , then  $v =$

- (A)  $\frac{E}{m^2}$
- (B)  $\frac{1}{2}mE^2$
- (C)  $\sqrt{\frac{2E}{m}}$
- (D)  $\sqrt{\frac{E}{2m}}$

46. If  $16x^2 + bx + 100$  is a perfect square, then  $b$  is

- (A) 40
- (B) 58
- (C) 80
- (D) 116

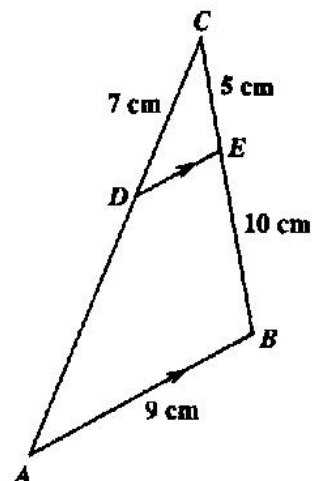

47. In the diagram above, not drawn to scale,  $DE$  is parallel to  $AB$ ,  $AB = 9$  cm,  $BE = 10$  cm,  $EC = 5$  cm and  $CD = 7$  cm. What is the length of  $AC$ ?

- (A)  $10\frac{1}{2}$  cm
- (B) 12 cm
- (C) 14 cm
- (D) 21 cm

GO ON TO THE NEXT PAGE

48. The length of the arc which subtends an angle  $\theta$  at the centre of a circle of radius  $r$  cm is

- (A)  $\frac{\theta}{360} \times \pi r$   
 (B)  $\frac{\theta}{360} \times \pi r^2$   
 (C)  $\frac{\theta}{360} \times 2\pi r$   
 (D)  $\frac{\theta}{360} \times 2\pi r^2$

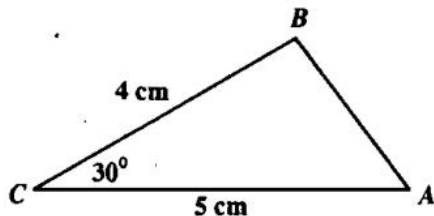

49. In the triangle above, not drawn to scale,  $BC = 4$  cm,  $CA = 5$  cm and angle  $BCA = 30^\circ$ . The area of triangle  $ABC$  is

- (A)  $5 \text{ cm}^2$   
 (B)  $10 \text{ cm}^2$   
 (C)  $17 \text{ cm}^2$   
 (D)  $20 \text{ cm}^2$

50.  $P$  and  $Q$  are two finite sets such that  $n(P) = 7$ ,  $n(Q) = 5$  and  $n(P \cap Q) = 3$ . What is  $n(P \cup Q)$ ?

- (A) 6  
 (B) 9  
 (C) 15  
 (D) 18

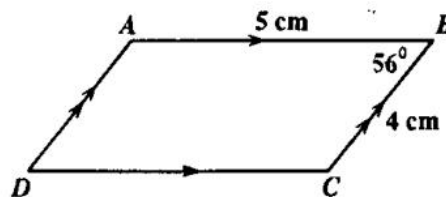

51. In the parallelogram  $ABCD$  above, not drawn to scale,  $AB = 5$  cm,  $BC = 4$  cm and angle  $ABC = 56^\circ$ . What is the area of the parallelogram  $ABCD$ ?

- (A)  $5 \sin 56^\circ \text{ cm}^2$   
 (B)  $10 \sin 56^\circ \text{ cm}^2$   
 (C)  $20 \sin 56^\circ \text{ cm}^2$   
 (D)  $40 \sin 56^\circ \text{ cm}^2$

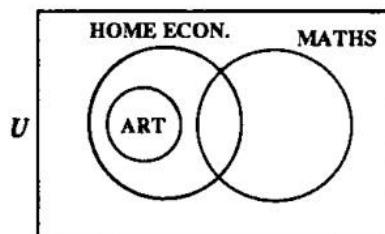

52. The Venn diagram above gives information on students who are studying Home Economics, Mathematics and Art. Which of the following deductions can be made?

- I. Some students who study Art study Home Economics.  
 II. No student who studies Art studies Mathematics.  
 III. Some Home Economics students study Mathematics.

- (A) I and II only  
 (B) II and III only  
 (C) I and III only  
 (D) I, II and III

53. A rectangle is 16 cm long and 9 cm wide. A square has the same area as the rectangle. What is the length of a side of the square?

- (A) 12 cm  
 (B) 24 cm  
 (C) 36 cm  
 (D) 72 cm

GO ON TO THE NEXT PAGE

54. The coordinates of the image of the point  $(4, 0)$  under reflection in the line  $x = 6$  is

(A)  $(-4, 0)$   
 (B)  $(8, 0)$   
 (C)  $(10, 0)$   
 (D)  $(4, 12)$

55. A rectangle which is 3 times as long as it is wide, has a width of  $p$  centimetres. Its perimeter is

(A)  $4p$  centimetres  
 (B)  $8p$  centimetres  
 (C)  $3p^2$  centimetres  
 (D)  $p + 3$  centimetres

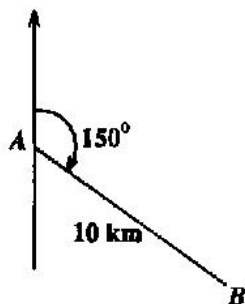

56. A plane travels from point  $A$  on a bearing  $150^\circ$  to a point  $B$  10 km from  $A$ . How far east of  $A$  is  $B$ ?

(A)  $10 \sin 30^\circ$   
 (B)  $10 \sin 60^\circ$   
 (C)  $10 \cos 30^\circ$   
 (D)  $10 \tan 60^\circ$

57. Mr. Smith's weekly salary was increased from \$210 to \$280. His assistant's salary was increased proportionately. If his assistant's salary is now \$200, then the assistant's salary before the increase was

(A) \$130  
 (B) \$140  
 (C) \$150  
 (D) \$270

58. An agent received 30% commission on sales exceeding a value of \$400. If he receives \$120 commission, how much did he actually sell?

(A) \$400  
 (B) \$412  
 (C) \$600  
 (D) \$800

59. The sum of the interior angles of a regular polygon is  $720^\circ$ . If one side of the polygon is 10 cm, then the perimeter of the polygon is

(A) 50 cm  
 (B) 60 cm  
 (C) 80 cm  
 (D) 100 cm

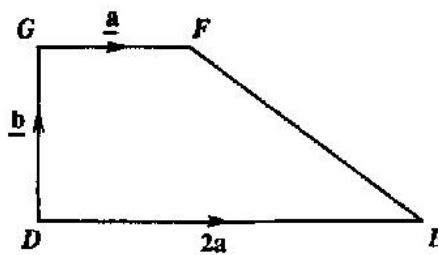

60. In the figure  $DEFG$  above,  $\vec{DE} = 2\vec{a}$ ,  $\vec{DG} = \vec{b}$  and  $\vec{GF} = \vec{a}$ . What is  $\vec{EG}$  expressed in terms of  $\vec{a}$  and  $\vec{b}$ ?

(A)  $\vec{a} + \vec{b}$   
 (B)  $\vec{b} + \vec{a}$   
 (C)  $2\vec{a} + \vec{b}$   
 (D)  $\vec{b} - 2\vec{a}$

IF YOU FINISH BEFORE TIME IS CALLED, CHECK YOUR WORK ON THIS TEST.

1. What is the value of the digit 3 in the number 32417?

- (A) 3
- (B) 30
- (C) 300
- (D) 3 000

2. 0.75 written as a common fraction is

- (A)  $\frac{1}{4}$
- (B)  $\frac{1}{2}$
- (C)  $\frac{3}{4}$
- (D)  $\frac{7}{8}$

3. In the sequence 1, 6, 13, 22, 33 the next term is

- (A) 44
- (B) 45
- (C) 46
- (D) 52

4.

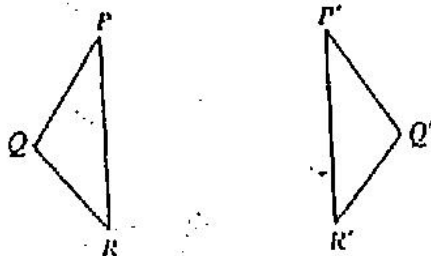

What transformation maps  $\Delta PQR$  onto  $\Delta P'Q'R'$ ?

- (A) Translation
- (B) Reflection
- (C) Rotation
- (D) Enlargement

5.  $\left(\frac{2}{3}\right)^2$  is the same as

- (A)  $\frac{4}{6}$
- (B)  $\frac{4}{3}$
- (C)  $\frac{2}{9}$
- (D)  $\frac{4}{9}$

6. If  $P = \{2, 3, 5, 7\}$   
 $Q = \{2, 3, 6\}$   
 and  $S = \{2, 4, 5\}$ ,

then  $P \cap Q \cap S =$

- (A)  $\{ \}$
- (B)  $\{2\}$
- (C)  $\{2, 3\}$
- (D)  $\{2, 3, 4, 5, 6, 7\}$

7. Which of the following sets is equivalent to  $\{a, b, c, d\}$ ?

- (A)  $\{4\}$
- (B)  $\{a, b, c\}$
- (C)  $\{p, q, r, s\}$
- (D)  $\{1, 2, 3, 4, 5\}$

8. The product of a number  $p$  and its reciprocal may be written as

- (A)  $p^2 \times \frac{1}{p}$
- (B)  $p^2 \times -p$
- (C)  $p \times -p$
- (D)  $p \times \frac{1}{p}$

9.  $2a^3 \times 3a =$

- (A)  $5a^3$
- (B)  $6a^2$
- (C)  $6a^3$
- (D)  $12a^3$

10. If  $a = 4$ , and  $u = 3$ . Then  $(-a)^u =$

- (A)  $-81$
- (B)  $-64$
- (C)  $-12$
- (D)  $+12$

11.  $5x - 2y - 3x + 2y =$

- (A)  $2x$
- (B)  $8x$
- (C)  $2x - 4y$
- (D)  $8x + 4y$

12. A boy scored 60% in a test. If the maximum mark possible was 80, how many marks did he score on the test?

- (A) 20
- (B) 48
- (C) 60
- (D) 75

13.  $\frac{15x + 12}{3} =$

- (A)  $17x$
- (B)  $15x + 4$
- (C)  $5x + 12$
- (D)  $5x + 4$

14.  $(a - b)^2 =$

- (A)  $a^2 - b^2$
- (B)  $a^2 + b^2$
- (C)  $a^2 - 2ab - b^2$
- (D)  $a^2 - 2ab + b^2$

15.

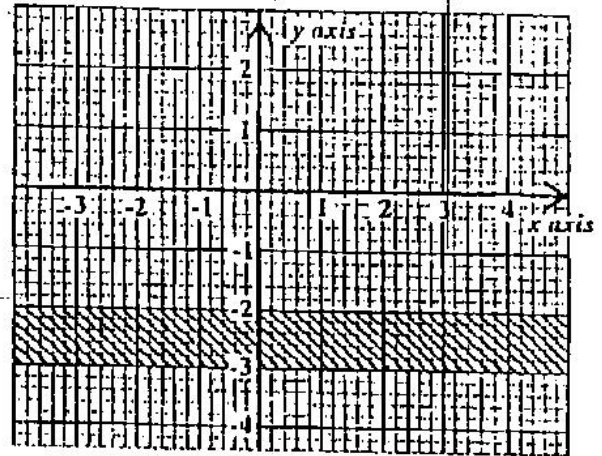

In the figure above, the shaded area can be represented by

- (A)  $\{-3 \leq x \leq -2\}$
- (B)  $\{-3 \geq x \geq -2\}$
- (C)  $\{-3 \leq y \leq -2\}$
- (D)  $\{-3 \geq y \geq -2\}$

16. Which of these drawings represents a square pyramid?

(A)

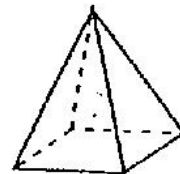

(B)

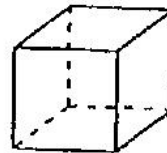

(C)



(D)

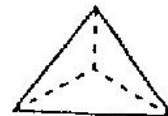

17. How many kilograms are there in one tonne?

- (A) 10  
 (B) 100  
 (C) 1 000  
 (D) 10 000

18. "How a housewife divides her budget."  
 Which of the following best displays the answer?

- (A) Bar chart  
 (B) Histogram  
 (C) Line graph  
 (D) Pie chart.

19. In a class of 120 students, 100 are girls.  
 What is the probability that a student chosen at random is a boy?

- (A)  $\frac{1}{6}$   
 (B)  $\frac{1}{5}$   
 (C)  $\frac{1}{2}$   
 (D)  $\frac{5}{6}$

20. An article bought for \$125 was sold for \$175. The percentage profit was

- (A) 28.6  
 (B) 40  
 (C) 50  
 (D) 71.4

21.  $299.4 \times 0.05$  is approximately

- (A) 0.15  
 (B) 1.5  
 (C) 15  
 (D) 150

22. Which of the following is a subset of  $\{1, 2, 3\}$ ?

- (A)  $\{1, 3\}$   
 (B)  $\{0, 3\}$   
 (C)  $\{2, 4\}$   
 (D)  $\{1, 2, 3, 4\}$

Item 23 refers to the figure below which shows the number of leaves on rose-stems.

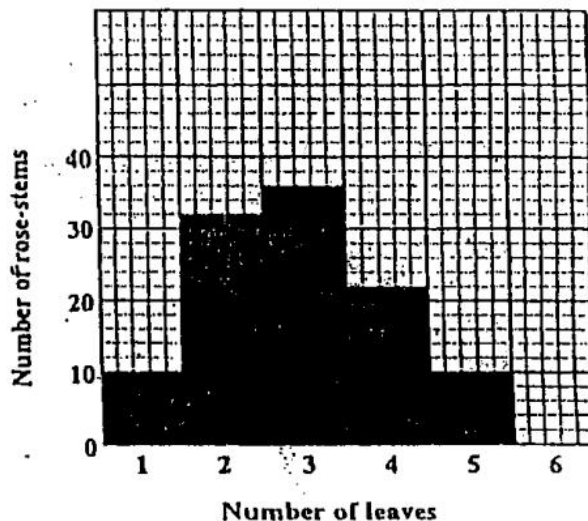

23. The total number of rose-stems is

- (A) 36  
 (B) 40  
 (C) 100  
 (D) 110

24.

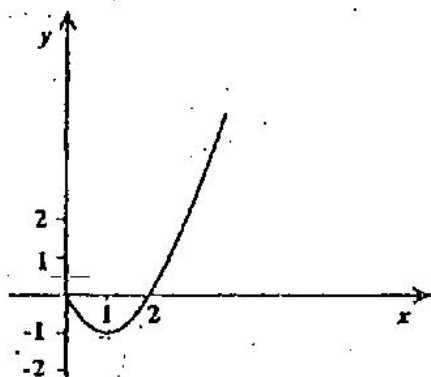

The diagram above shows a graph of  $y = x(x - 2)$ . The minimum point is

- (A) (0, 0)
- (B) (2, 0)
- (C) (1, 1)
- (D) (1, -1)

25.

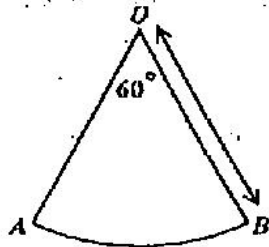

$AOB$  is a sector of a circle such that angle  $AOB = 60^\circ$  and  $OB$  is  $r$  units long. The area of  $AOB$  is

- (A)  $\frac{1}{6} \pi r$
- (B)  $\frac{1}{3} \pi r$
- (C)  $\frac{1}{3} \pi r^2$
- (D)  $\frac{1}{6} \pi r^2$

26.

Tom bought a pen for \$60 and sold it to gain 20% on his cost price. How much money did he gain?

- (A) \$12
- (B) \$40
- (C) \$72
- (D) \$80

27.

When the sum of  $x$  and 6 is multiplied by 2 and the result added to 3, the answer is 5. The statement above may be written as

- (A)  $2x + 6 + 3 = 5$
- (B)  $x + 6(6 \times 2) + 3 = 5$
- (C)  $6x \times 2 + 3 = 5$
- (D)  $2(x + 6) + 3 = 5$

28.

If  $x$  is an integer which satisfies the inequalities

$$4 < x - 2 < 8, \text{ then } x \text{ may be}$$

- (A) 4
- (B) 5
- (C) 6
- (D) 7

29.

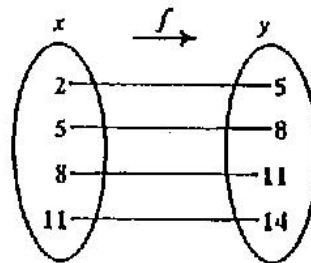

The arrow diagram above shows a function. Which of the following BEST describes the function?

- (A)  $f: x \rightarrow y$
- (B)  $y = x$
- (C)  $x = y + 3$
- (D)  $y = x + 3$

30. In which of the following are the fractions arranged from the smallest to the greatest?

- (A)  $\left\{ \frac{1}{2}, \frac{1}{3}, \frac{1}{4}, \frac{1}{5} \right\}$   
 (B)  $\left\{ \frac{1}{2}, \frac{1}{4}, \frac{1}{3}, \frac{1}{5} \right\}$   
 (C)  $\left\{ \frac{1}{5}, \frac{1}{4}, \frac{1}{3}, \frac{1}{2} \right\}$   
 (D)  $\left\{ \frac{1}{5}, \frac{1}{3}, \frac{1}{4}, \frac{1}{2} \right\}$

31.

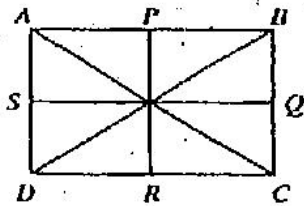

$ABCD$  is a rectangle. The points  $P$ ,  $Q$ ,  $R$  and  $S$  are midpoints of the sides  $AB$ ,  $BC$ ,  $CD$  and  $DA$  respectively. The two axes of symmetry are

- (A)  $AC$  and  $BD$   
 (B)  $PR$  and  $SQ$   
 (C)  $AC$  and  $PR$   
 (D)  $SQ$  and  $BD$

Item 32 refers to the diagram below.

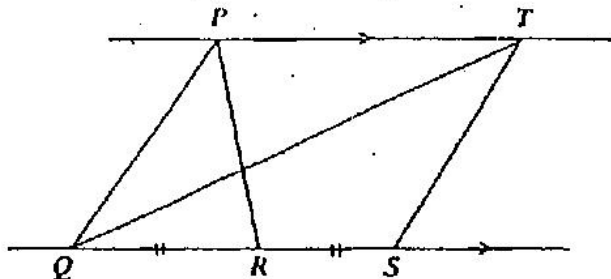

32. In the diagram,  $PT$  is parallel to  $QS$ , and  $QR = RS$ . Then the ratio  $\frac{\text{area of } \triangle TQS}{\text{area of } \triangle PQR}$  is

- (A) 1 : 1  
 (B) 2 : 1  
 (C) 3 : 1  
 (D) 4 : 1

33.

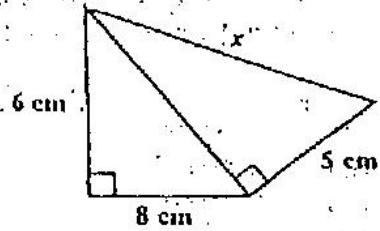

In the figure above,  $x =$

- (A) 9 cm  
 (B)  $\sqrt{75}$  cm  
 (C) 10 cm  
 (D)  $\sqrt{125}$  cm

34. Which of the following is NOT a quadrilateral?

- (A) Square  
 (B) Pentagon  
 (C) Parallelogram  
 (D) Rhombus

35.  $\sqrt{520}$  is approximately

- (A)  $2.3 \times 10$   
 (B)  $2.3 \times 10^2$   
 (C)  $7.2 \times 10$   
 (D)  $7.2 \times 10^2$

36. Mr Jones paid a fixed charge of \$12.50 plus 55 cents for each Kwh of electricity used. How much did he pay for using 75 Kwh of electricity?

- (A) \$ 13.80  
 (B) \$ 41.25  
 (C) \$ 53.75  
 (D) \$142.50

37. During a sale a discount of 15% was given off the marked price of a chair. If the marked price was \$115.00, then the sale price was

- (A) \$ 97.75
- (B) \$100.00
- (C) \$130.00
- (D) \$132.25

38. The exact value of  $2 \div (0.01)$  is

- (A) 0.002
- (B) 0.02
- (C) 200
- (D) 2 000

39. The width of a rectangular block of wood is  $x$  centimetres. If its height is two-thirds its width and its length is 4 times its height, then its volume, in cubic centimetres is

- (A)  $\frac{8x}{9}$
- (B)  $\frac{16x^3}{9}$
- (C)  $\frac{8x^3}{3}$
- (D)  $\frac{17x}{3}$

40. A car was bought for \$10 000 in January 1997. If the car depreciates by 10% every year, what was its worth in January 2000?

- (A) \$3 000
- (B) \$7 290
- (C) \$8 000
- (D) \$9 000

41. The simple interest on \$15 000 for three months at 10% per annum is

- (A) \$ 375
- (B) \$ 500
- (C) \$1 500
- (D) \$4 500

42.

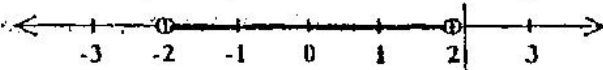

The graph of the inequality in the diagram above is defined by

- (A)  $-2 < x < 2$
- (B)  $-2 < x \leq 2$
- (C)  $-2 \leq x \leq 2$
- (D)  $-2 \leq x < 2$

43.

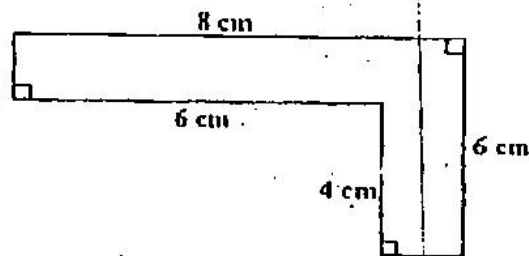

What is the perimeter of the shape above?

- (A) 24 cm
- (B) 26 cm
- (C) 28 cm
- (D) 48 cm

44. The set  $\{x : 6 \leq x < 10, \text{ where } x \text{ is an integer}\}$  is

- (A)  $\{6, 7, 8, 9\}$
- (B)  $\{6, 7, 8, 9, 10\}$
- (C)  $\{7, 8, 9\}$
- (D)  $\{7, 8, 9, 10\}$

45.

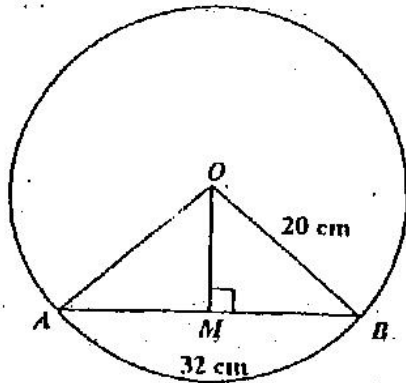

In the figure above, not drawn to scale,  $O$  is the centre of the circle,  $AB$  is a chord and  $OM$  is perpendicular to  $AB$ . If  $OB = 20$  cm and  $AB = 32$  cm, then  $OM =$

- (A) 8 cm
- (B) 10 cm
- (C) 12 cm
- (D) 16 cm

Item 46 refers to the following diagram.

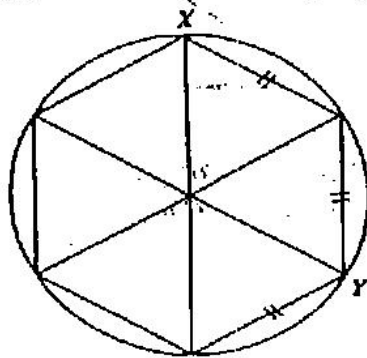

46. The diagram above shows a regular hexagon inscribed in a circle. The distance between  $X$  and  $Y$  along the arc is

- (A)  $\frac{\pi R}{3}$
- (B)  $\frac{2\pi R}{3}$
- (C)  $\frac{\pi R^2}{3}$
- (D)  $\frac{2\pi R^2}{3}$

47. Jerry takes 16 minutes to drive to his workplace which is 24 km away from his home. His speed in km per hour is

- (A)  $\frac{16}{24} \times \frac{1}{60}$
- (B)  $\frac{24}{60} \times \frac{16}{1}$
- (C)  $\frac{16}{24} \times \frac{60}{1}$
- (D)  $\frac{24}{16} \times \frac{60}{1}$

48. Each exterior angle of a regular polygon measures  $45^\circ$ . How many sides has the polygon?

- (A) 4
- (B) 6
- (C) 8
- (D) 10

49. If  $(P - 3)$  is the largest of four odd numbers, then the smallest is

- (A)  $P - 11$
- (B)  $P - 9$
- (C)  $P + 3$
- (D)  $P + 5$

50. An article costs \$161. If a profit of 13% is to be made when selling, the selling price, in dollars, is

- (A)  $161\left(1 + \frac{13}{100}\right)$
- (B)  $13\left(1 + \frac{161}{100}\right)$
- (C)  $161\left(13 + \frac{1}{100}\right)$
- (D)  $13\left(161 + \frac{1}{100}\right)$

51. A company employs 12 gardeners at \$26 per day, and 8 clerks at \$17 per day. What is the mean daily wage, in dollars, of the 20 employees?

- (A) \$20.00
- (B) \$21.50
- (C) \$22.40
- (D) \$31.50

Items 52 – 53 refer to the table below.

A die is thrown and the scores recorded as shown.

Score	1	2	3	4	5	6
Frequency	2	1	3	6	5	3

52. The median score is

- (A) 3
- (B) 4
- (C) 5
- (D) 6

53. The mean score is

- (A) 3.7
- (B) 4
- (C) 5
- (D) 13.3

54.

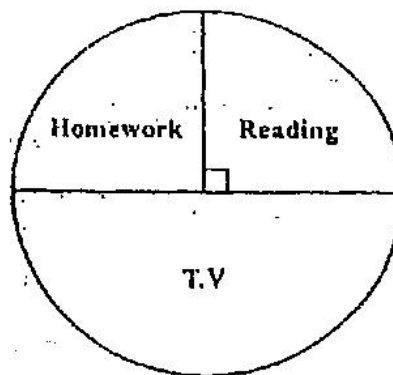

The diagram above shows how a pupil spends the time between 8 a.m. and 8 p.m. on Saturdays.

How many hours does he spend on T.V.?

- (A) 2
- (B) 3
- (C) 4
- (D) 6

55.

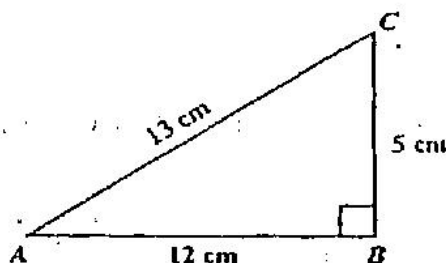

In triangle ABC above,  $AB = 12$  cm,  $AC = 13$  cm,  $BC = 5$  cm. What is  $\tan C$ ?

- (A)  $\frac{5}{13}$
- (B)  $\frac{12}{13}$
- (C)  $\frac{12}{5}$
- (D)  $\frac{13}{5}$

Items 56 and 57 refer to the graph below. 58.

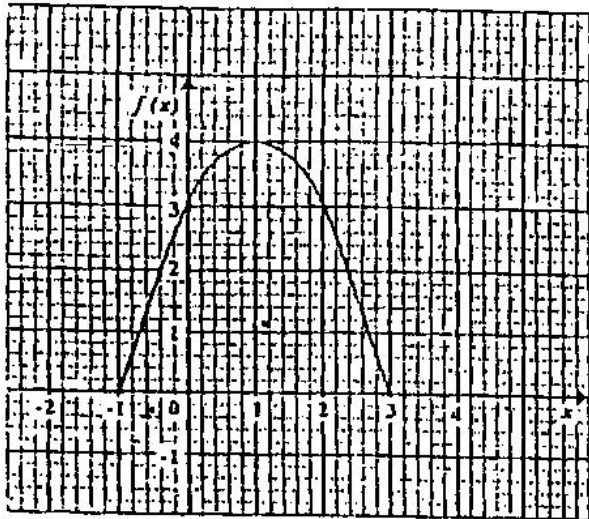

56. Which of the following represents the equation of the graph above?

- (A)  $f(x) = 3 + 2x - x^2$
- (B)  $f(x) = x^2 - 2x - 3$
- (C)  $f(x) = x^2 + 2x - 3$
- (D)  $f(x) = 3 - 2x - x^2$

57. The values of  $x$  for which  $f(x) = 0$  are

- (A)  $x = 3$  and  $x = 4$
- (B)  $x = 1$  and  $x = 4$
- (C)  $x = -1$  and  $x = 3$
- (D)  $x = 0$  and  $x = 3$

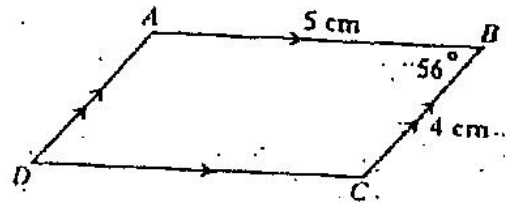

In the parallelogram  $ABCD$  above,  $AB = 5$  cm,  $BC = 4$  cm and angle  $ABC = 56^\circ$ . What is the area of the parallelogram  $ABCD$ ?

- (A)  $5 \sin 56^\circ \text{ cm}^2$
- (B)  $5 \cos 56^\circ \text{ cm}^2$
- (C)  $20 \sin 56^\circ \text{ cm}^2$
- (D)  $10 \cos 56^\circ \text{ cm}^2$

59.

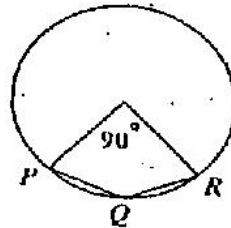

In the figure above,  $O$  is the centre of the circle. Angle  $PQR$  is

- (A)  $11^\circ$
- (B)  $90^\circ$
- (C)  $135^\circ$
- (D)  $150^\circ$

60.

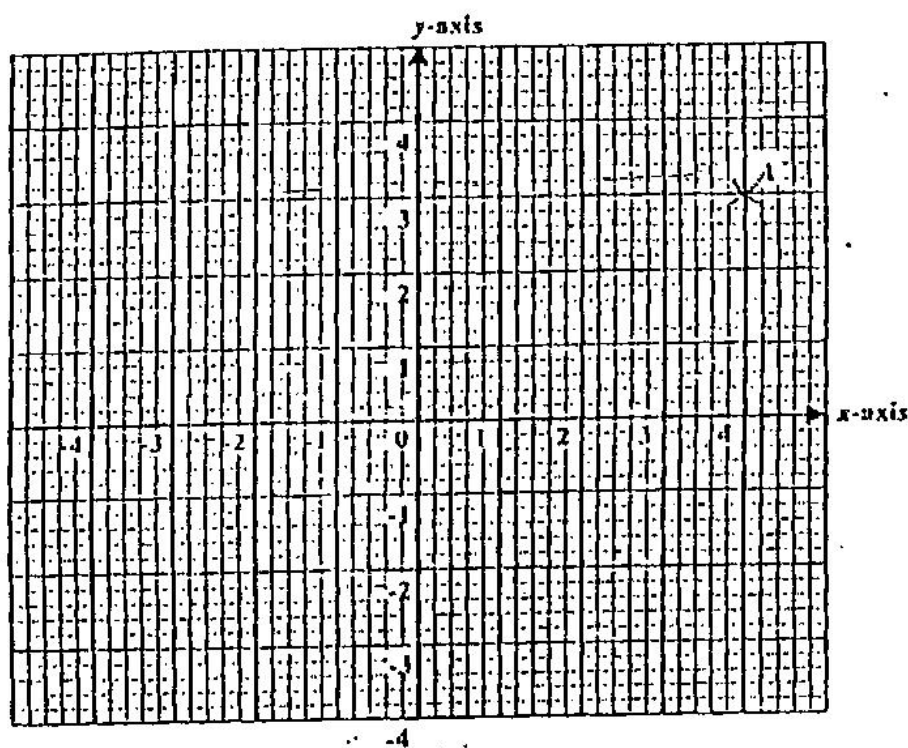

The point  $A$  is shown on the diagram above.  
What are the co-ordinates of the image of  $A$   
under reflection in the  $y$ -axis?

- (A)  $(-4, 3)$
- (B)  $(4, -3)$
- (C)  $(3, -4)$
- (D)  $(-3, 4)$

↑ AFFIX SEAL HERE ↑

**CANDIDATE –PLEASE NOTE!**

You must sign below and return this booklet with the Answer Sheet. Failure to do so may result in disqualification.

\_\_\_\_\_  
SignatureTEST CODE **01234010**

MAY/JUNE 2004

**FORM TP 2007104**

**CARIBBEAN EXAMINATIONS COUNCIL**  
**SECONDARY EDUCATION CERTIFICATE**  
**EXAMINATION**  
**MATHEMATICS**  
**Paper 01 – General Proficiency**  
*90 minutes*

27 MAY 2004 (p.m.)

**READ THE FOLLOWING DIRECTIONS CAREFULLY**

1. In addition to this test booklet, you should have an answer sheet.
2. Calculators and mathematical tables may NOT be used for this paper.
3. **A list of formulae is provided on page 2 of this booklet.**
4. This test consists of 60 items. You will have 90 minutes to answer them.
5. Each item in this test has four suggested answers, lettered (A), (B), (C), (D). Read each item you are about to answer, and decide which choice is best.
6. On your answer sheet, find the number which corresponds to your item and blacken the space having the same letter as the answer you have chosen. Look at the sample item below.

Sample Item

$2a + 6a =$

- (A)  $8a$   
 (B)  $8a^2$   
 (C)  $12a$   
 (D)  $12a^2$

Sample Answer

The best answer to this item is “ $8a$ ”, so answer space (A) has been blackened.

7. If you want to change your answer, erase your old answer completely and fill in your new choice.
8. When you are told to begin, turn the page and work as quickly and as carefully as you can. If you cannot Answer an item, omit it and go on to the next one. You can return later to the item omitted. Your score will be the total number of correct answers.
9. You may do any rough work in the booklet.
10. Do not be concerned that the answer sheet provides spaces for more answers than there are items in this test.

**DO NOT TURN THIS PAGE UNTIL YOU ARE TOLD TO DO SO.**

Copyright © 2003 Caribbean Examinations Council ®.

**LIST OF FORMULAE**

Volume of a prism  $V = Ah$  where  $A$  is the area of a cross-section and  $h$  is the perpendicular length.

Volume of a cylinder  $V = \pi r^2 h$  where  $r$  is the radius of the base and  $h$  is the perpendicular height.

Volume of a right pyramid  $V = \frac{1}{3}Ah$  where  $A$  is the area of the base and  $h$  is the perpendicular height.

Circumference  $C = 2\pi r$  where  $r$  is the radius of the circle.

Area of a circle  $A = \pi r^2$  where  $r$  is the radius of the circle.

Area of Trapezium  $A = \frac{1}{2}(a + b)h$  where  $a$  and  $b$  are the lengths of the parallel sides and  $h$  is the perpendicular distance between the parallel sides.

Roots of quadratic equations If  $ax^2 + bx + c = 0$ ,  
 then  $x = \frac{-b \pm \sqrt{b^2 - 4ac}}{2a}$

Trigonometric ratios

$$\sin \theta = \frac{\text{opposite side}}{\text{hypotenuse}}$$

$$\cos \theta = \frac{\text{adjacent side}}{\text{hypotenuse}}$$

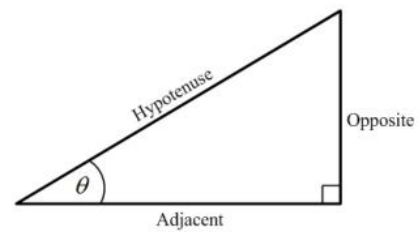
$$\tan \theta = \frac{\text{opposite side}}{\text{adjacent side}}$$

Area of triangle Area of  $\Delta = \frac{1}{2}bh$  where  $b$  is the length of the base and  $h$  is the perpendicular height

$$\text{Area of } \Delta ABC = \frac{1}{2}ab \sin C$$

$$\text{Area of } \Delta ABC = \sqrt{s(s-a)(s-b)(s-c)}$$

$$\text{where } s = \frac{a+b+c}{2}$$

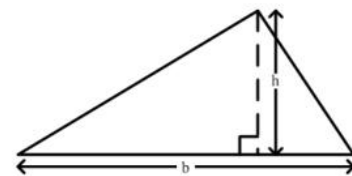

Sine rule  $\frac{a}{\sin A} = \frac{b}{\sin B} = \frac{c}{\sin C}$

Cosine rule  $a^2 = b^2 + c^2 - 2bc \cos A$

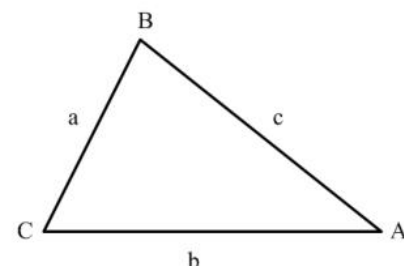

1. 0.45 may be written as

(A)  $\frac{9}{20}$

(B)  $\frac{4}{5}$

(C)  $\frac{9}{10}$

(D)  $\frac{5}{4}$

2. The number 3.14063 written correct to 3 decimal places is

(A) 3.140

(B) 3.141

(C) 3.146

(D) 3.150

3. The number 3076 written in standard form is

(A)  $3.076 \times 10^{-3}$

(B)  $3.076 \times 10^{-2}$

(C)  $3.076 \times 10^2$

(D)  $3.076 \times 10^3$

Item 4 refers to the following diagram

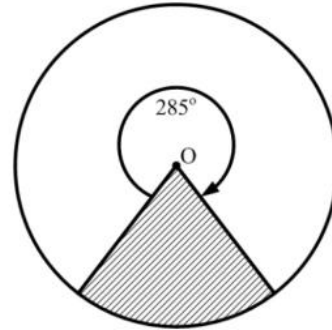

4. The fraction of the circle which has been shaded is

(A)  $\frac{5}{24}$

(B)  $\frac{8}{24}$

(C)  $\frac{15}{24}$

(D)  $\frac{19}{24}$

5. The EXACT value of  $2 \div (0.01)^2$  is

(A) 0.0002

(B) 0.0005

(C) 5000

(D) 20000

6. In a school, the ratio of the number of pupils to the number of teachers is 20 : 1. If the number of pupils is 840, how many teachers are there?

- (A) 40
- (B) 42
- (C) 800
- (D) 840

7.  $P = \{52, 77, 91, 124, 217\}$

Three members of the set  $P$  have a common factor which is

- (A) 4
- (B) 7
- (C) 13
- (D) 31

Item 8 refers to the diagram below.

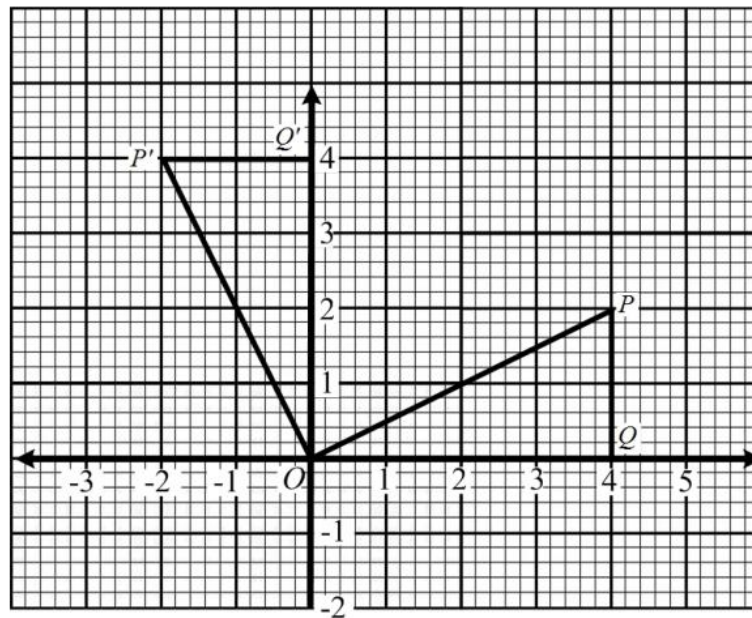

8. In the figure above,  $\Delta OPQ$  is mapped to  $\Delta OP'Q'$ . What type of transformation has taken place?

- (A) Reflection
- (B) Shear
- (C) Translation
- (D) Rotation

9. 301 can be written as

- (A)  $3 \times 10^2 + 1$
- (B)  $3 \times 10^3 + 1$
- (C)  $3 \times 10^2 + 1 \times 10$
- (D)  $3 \times 10^3 + 1 \times 10$

10. If  $p = 3(a - q)$ , then  $6a$  is equal to

- (A)  $2(p + 3q)$
- (B)  $2(p + q)$
- (C)  $p + 3q$
- (D)  $p + q$

11. Which of the following sets is equivalent to  $\{a, b, c, d\}$ ?

- (A)  $\{4\}$
- (B)  $\{a, b, c\}$
- (C)  $\{p, q, r, s\}$
- (D)  $\{1, 2, 3, 4, 5\}$

12. If  $Q = \{a, b, c, d, e\}$  how many subsets can be obtained from the set  $Q$ ?

- (A)  $2 + 5$
- (B)  $2 \times 5$
- (C)  $5^2$
- (D)  $2^5$

Item 13 refers to the following Venn diagram

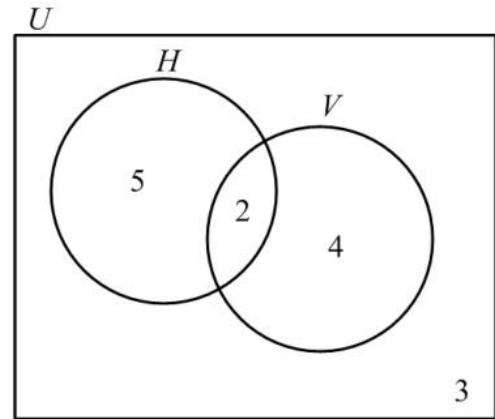

13. In the Venn diagram above

$U = \{\text{students who play games}\}$

$H = \{\text{students who play hockey}\}$

$V = \{\text{students who play volleyball}\}$

The number of students in each set is indicated.  
How many students do NOT play volleyball?

- (A) 2
- (B) 3
- (C) 5
- (D) 8

Item 14 refers to the following diagram.

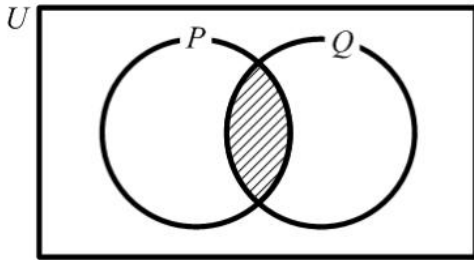

14. The two circles above represent set  $P$  and set  $Q$ . If  $P = \{\text{factors of } 6\}$  and  $Q = \{\text{factors of } 4\}$ , then the shaded region represents
- (A)  $\{\}$   
 (B)  $\{1, 2\}$   
 (C)  $\{4, 6, 8, \dots\}$   
 (D)  $\{12, 24, 36, \dots\}$
15. A woman buys a pair of shoes at a sale. She pays \$45, saving \$15 on the normal price. The percentage discount on the pair of shoes is
- (A) 25  
 (B) 30  
 (C)  $33\frac{1}{3}$   
 (D) 80
16. Tom bought a pen for \$60 and sold it to gain 20% on his cost price. How much money did he gain?
- (A) \$12  
 (B) \$40  
 (C) \$72  
 (D) \$80
17. During a sale, a shop allows 20% discount off the marked price of clothing. What will a customer pay for a dress with a marked price of \$30 ?
- (A) \$10  
 (B) \$20  
 (C) \$24  
 (D) \$30
18. A customer buys a table on hire purchase. He makes a deposit of \$306 and pays six monthly installments of \$60 each. The TOTAL cost to the customer is
- (A) \$360  
 (B) \$366  
 (C) \$666  
 (D) \$966
19. A dinner in a hotel was advertised at \$60 plus 18% Tax. The total bill for one dinner was
- (A) \$60.00  
 (B) \$70.80  
 (C) \$78.00  
 (D) \$81.60
20. The simple interest on \$400 at 5% per annum for 2 years is given by
- (A)  $\$ \frac{400 \times 5 \times 2}{100}$   
 (B)  $\$ \frac{100 \times 5 \times 2}{400}$   
 (C)  $\$ \frac{400 \times 2}{5 \times 100}$   
 (D)  $\$ \frac{400 \times 100}{2 \times 5}$

21. If the simple interest on \$800 for 3 years is \$54, what is the rate of interest per annum?
- (A)  $\frac{4}{9}\%$   
 (B)  $2\frac{1}{4}\%$   
 (C) 5%  
 (D) 44%
22. A plot of land is valued at \$18 000. Land tax is charged at the rate of \$0.70 per \$100 value. What is the TOTAL amount of tax paid for the land?
- (A) \$110.00  
 (B) \$126.00  
 (C) \$180.70  
 (D) \$257.15
23. The expression 'y is equal to the square of x' can be written as
- (A)  $y = x^2$   
 (B)  $y^2 = x$   
 (C)  $y = 2x$   
 (D)  $y = \sqrt{x}$
24. The expression  $-2(x-4)$  is the same as
- (A)  $-2x-8$   
 (B)  $-2x-4$   
 (C)  $-2x+4$   
 (D)  $-2x+8$
25. "When 7 is added to 3 times a certain number  $n$ , the result is 22".  
 The statement above may be represented by the equation
- (A)  $3n+7=22$   
 (B)  $7n-22=3$   
 (C)  $3n+22=7$   
 (D)  $7n+3=22$
26. John had  $x$  marbles and Max had twice as many. Max gives Tom 5 of his marbles. How many marbles does Max now have?
- (A)  $x+5$   
 (B)  $x-5$   
 (C)  $2x+5$   
 (D)  $2x-5$
27. Given that  $p * q$  means  $2q - p$ , the value of  $1 * 2$  is
- (A) 0  
 (B) 2  
 (C) 3  
 (D) 5
28. The expression  $(2a)^3$  is the same as
- (A)  $6a$   
 (B)  $8a$   
 (C)  $6a^3$   
 (D)  $8a^3$
29. If  $5(2x-1) = 35$ , then  $x =$
- (A)  $-4$   
 (B)  $\frac{1}{4}$   
 (C) 3  
 (D) 4
30. The sum of  $x$  and  $y$  is 18 and their difference is 14. Which pair of equations describes the above statement?
- (A)  $2(x+y) = 18$   
 $2(x-y) = 4$   
 (B)  $2(xy) = 18$   
 $2(x-y) = 4$   
 (C)  $(x+y) = 18$   
 $(x-y) = 14$   
 (D)  $(x+y) = 22$   
 $(x-y) = 14$

31. If  $15^2 = 225$ , then the square root of 0.0225 is
- (A) 0.015
  - (B) 0.15
  - (C) 1.5
  - (D) 15.0

32. Which of the following diagrams illustrates a function?

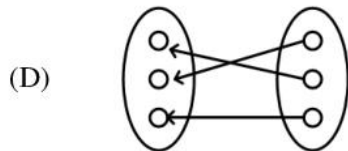
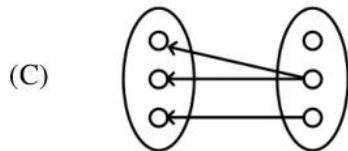
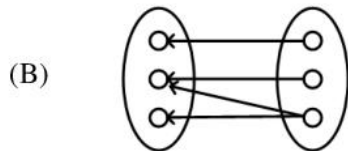
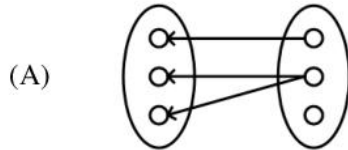

33. A function  $f$  is defined as  $f : x \rightarrow 3x - 1$ . The value of  $f(-3)$  is

- (A) -12
- (B) -10
- (C) -6
- (D) 12

34. Given  $f(x) = x^2 - 3x + 1$ , then  $f(-1)$  is

- (A) -3
- (B) 3
- (C) 5
- (D) 6

35. Which of the following represents the equation of a straight line?

- (A)  $y = \frac{4}{x}$
- (B)  $y = 2x + 3$
- (C)  $y = x^2 - 4$
- (D)  $y = x^2 + 2x - 5$

36.

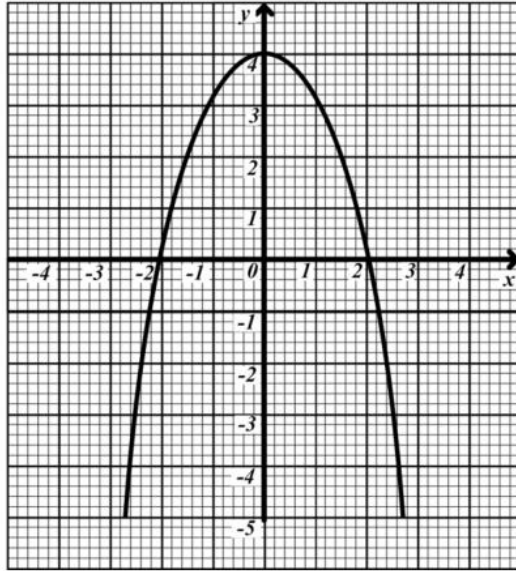

From the graph above, the values of  $x$  when  $y = -1$  are

- (A) 1 and -1
- (B) 2.2 and -2.2
- (C) 2.5 and -2.5
- (D) 2.8 and -2.8

Item 37 refers to the following diagram.

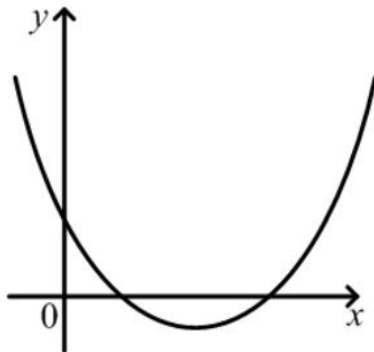

37. The diagram above shows a graph. If  $a$ ,  $b$  and  $c$  are constants and  $a > 0$ , the equation of the graph could be

- (A)  $y = ax^2 + c$
- (B)  $y = c - ax^2$
- (C)  $y = ax^2 + bx + c$
- (D)  $y = c + bx - ax^2$

38. The distance around the edge of a circular pond is 88 m. The radius, in metres, is

- (A)  $88\pi$   
 (B)  $176\pi$   
 (C)  $\frac{88}{\pi}$   
 (D)  $\frac{88}{2\pi}$

Item 39 refers to the following diagram.

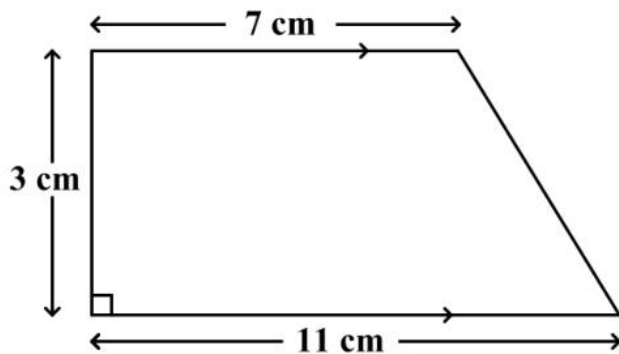

39. The area, in  $\text{cm}^2$ , of the trapezium above (not drawn to scale) is
- (A) 21  
 (B) 27  
 (C) 33  
 (D) 54

Item 40 refers to the following diagram.

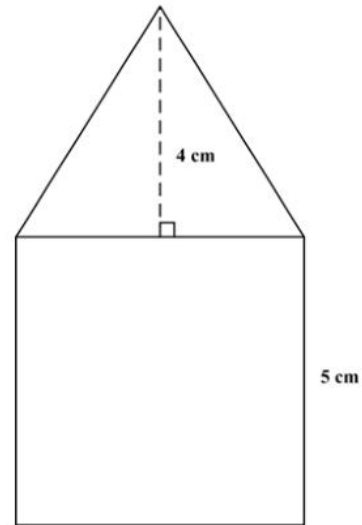

40. The figure above, **not drawn to scale**, consists of a triangle resting on a square of side 5 cm. The height of the triangle is 4 cm. What is the TOTAL area of the figure?
- (A)  $35 \text{ cm}^2$   
 (B)  $45 \text{ cm}^2$   
 (C)  $50 \text{ cm}^2$   
 (D)  $100 \text{ cm}^2$
41. The area of a rectangle is  $53.6 \text{ cm}^2$ . If the length is multiplied by four and the width is halved, the area would then be
- (A)  $26.8 \text{ cm}^2$   
 (B)  $53.6 \text{ cm}^2$   
 (C)  $107.2 \text{ cm}^2$   
 (D)  $214.4 \text{ cm}^2$

Item 42 refers to the following diagram.

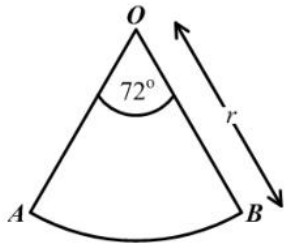

42.  $AOB$  is a sector of a circle such that angle  $AOB = 72^\circ$  and  $OB$  is  $r$  units long. The area of  $AOB$  is

- (A)  $\frac{1}{5}\pi r$
- (B)  $\frac{2}{5}\pi r$
- (C)  $\frac{1}{5}\pi r^2$
- (D)  $\frac{2}{5}\pi r^2$

43. How many kilograms are there in one tonne?

- (A) 10
- (B) 100
- (C) 1000
- (D) 10000

44. If it took a speed-boat 9 hours to travel a distance of 1080 km, what was its average speed in km/h?

- (A) 12 km/h
- (B) 102 km/h
- (C) 120 km/h
- (D) 1200 km/h

45. A man started a journey at 09:30 hrs and arrived at his destination in the same time zone at 13:30 hrs the same day. If his average speed was 30 km/h, then the distance in km for the journey was

- (A) 120
- (B) 133
- (C) 400
- (D) 430

Item 46 refers to the following diagram.

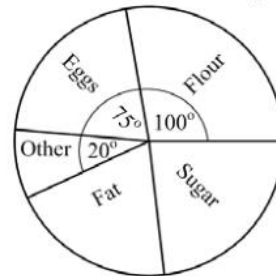

46. The pie chart above (**not drawn to scale**) represents the masses of ingredients in a cake. The total mass is 288g. What is the combined mass (in grams) of fat and sugar?

- (A) 93
- (B) 132
- (C) 165
- (D) 195

47. The pie chart (**drawn to scale**) shows how a student used 12 hours in studying English(E), Maths(M), French(F) and Geography(G).

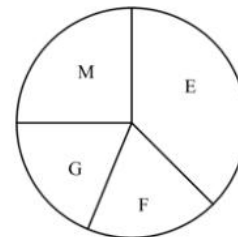

The amount of time spent studying Mathematics is APPROXIMATELY

- (A) 1 hr
- (B) 2 hrs
- (C) 3 hrs
- (D) 4 hrs

Item 48 refers to the following scores below.

10	15	4	7
8	8	1	4

48. The median of the eight scores presented above is

- (A) 4
- (B) 7.25
- (C) 7.50
- (D) 8

Item 49 refers to the following information.

2	5	9	18	18	27
---	---	---	----	----	----

49. The mode of the numbers is

- (A) 7
- (B) 16
- (C) 18
- (D) 25

50. Of 120 students writing an exam, 100 are expected to pass. The estimated probability of a student failing the exam is

- (A)  $\frac{1}{6}$
- (B)  $\frac{1}{5}$
- (C)  $\frac{1}{2}$
- (D)  $\frac{5}{6}$

51. When three coins are tossed simultaneously the possible outcomes are {HHH, HHT, HTH, HTT, THH, THT, TTH, TTT}, where H represents a Head and T represents a Tail. What is the probability of obtaining AT LEAST TWO heads?

- (A)  $\frac{1}{4}$
- (B)  $\frac{3}{8}$
- (C)  $\frac{1}{2}$
- (D)  $\frac{2}{3}$

Item 52 refers to the following diagram.

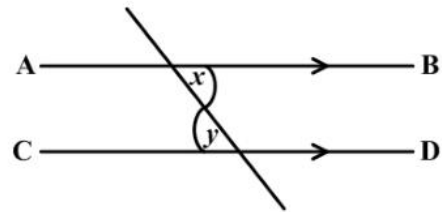

52. In the figure above  $AB$  and  $CD$  are parallel. Which of the following BEST describes the relation between  $x$  and  $y$ ?

- (A)  $x + y < 2x$
- (B)  $x = y$
- (C)  $x + y > 2x$
- (D)  $x < y$

Item 53 refers to the following diagram.

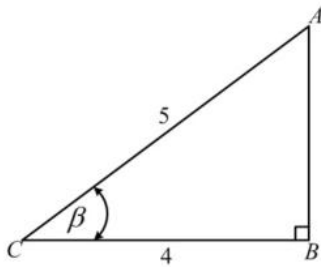

53. From the diagram above,  $\sin \beta$  is

- (A)  $\frac{3}{5}$
- (B)  $\frac{3}{4}$
- (C)  $\frac{4}{5}$
- (D)  $\frac{5}{3}$

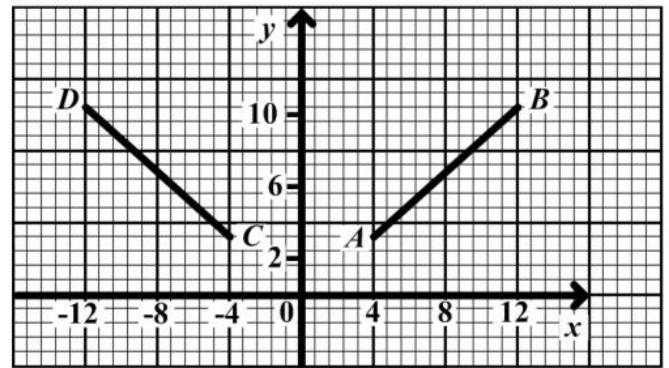

55. In the figure above, the line  $CD$  is the image of  $AB$  after a

- (A) a rotation through  $90^\circ$  centre  $O$
- (B) a reflection in the  $y$ -axis
- (C) a translation by vector  $\begin{pmatrix} -4 \\ -8 \end{pmatrix}$
- (D) an enlargement of scale factor  $-1$

Item 54 refers to the following diagram.

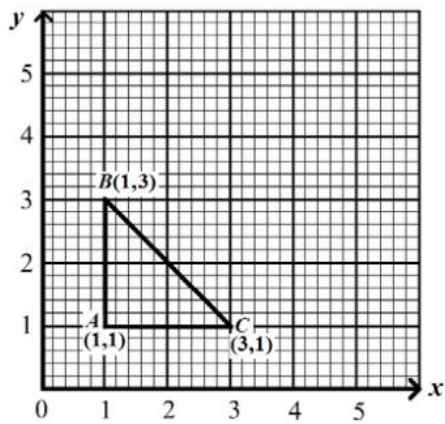

54.  $A'B'C'$  is the image of  $ABC$  under an enlargement by a scale factor 2. The area, in square units, of  $A'B'C'$  is

- (A) 2
- (B) 4
- (C) 8
- (D) 12

Item 56 refers to the following diagram.

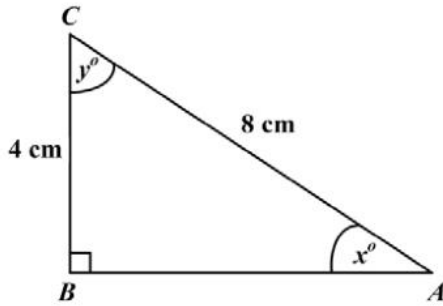

56. In the right-angled triangle above, which trigonometric ratio is equal to  $\frac{4}{8}$ ?

- (A)  $\tan y$
- (B)  $\cos x$
- (C)  $\sin x$
- (D)  $\tan x$

57. A rectangle has rotational symmetry of order

- (A) 1
- (B) 2
- (C) 3
- (D) 4

58. If the sum of the interior angles of a polygon is 4 right angles, then the polygon is a

- (A) triangle
- (B) hexagon
- (C) pentagon
- (D) quadrilateral

Item 59 refers to the following graph

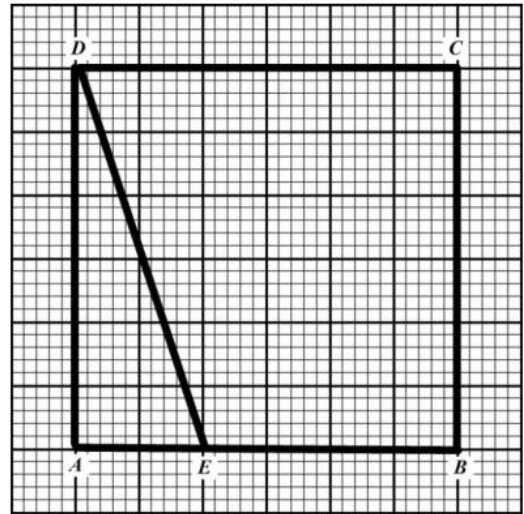

59. How many triangles congruent to  $\triangle ADE$  would be needed to cover the square  $ABCD$  entirely?

- (A) 2
- (B) 4
- (C) 6
- (D) 8

Item 60 refers to the following diagram.

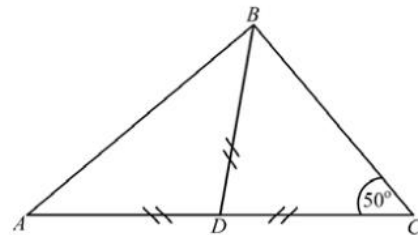

60. In the figure above,  $ABC$  is a triangle in which  $AD = BD = CD$ .

The angle  $ABC$  is

- (A)  $40^\circ$
- (B)  $50^\circ$
- (C)  $80^\circ$
- (D)  $90^\circ$

**IF YOU FINISH BEFORE TIME IS CALLED, CHECK YOUR WORK ON THIS TEST.**

↑ AFFIX SEAL HERE ↑

**CANDIDATE –PLEASE NOTE!**

You must sign below and return this booklet with the Answer Sheet. Failure to do so may result in disqualification.

\_\_\_\_\_  
SignatureTEST CODE **01234010**

JANUARY 2005

**FORM TP 2007104**

**CARIBBEAN EXAMINATIONS COUNCIL**  
**SECONDARY EDUCATION CERTIFICATE**  
**EXAMINATION**  
**MATHEMATICS**  
**Paper 01 – General Proficiency**  
*90 minutes*

04 JANUARY 2005 (p.m.)

**READ THE FOLLOWING DIRECTIONS CAREFULLY**

1. In addition to this test booklet, you should have an answer sheet.
2. Calculators and mathematical tables may NOT be used for this paper.
3. **A list of formulae is provided on page 2 of this booklet.**
4. This test consists of 60 items. You will have 90 minutes to answer them.
5. Each item in this test has four suggested answers, lettered (A), (B), (C), (D). Read each item you are about to answer, and decide which choice is best.
6. On your answer sheet, find the number which corresponds to your item and blacken the space having the same letter as the answer you have chosen. Look at the sample item below.

Sample Item

$2a + 6a =$

- (A)  $8a$   
 (B)  $8a^2$   
 (C)  $12a$   
 (D)  $12a^2$

Sample Answer

The best answer to this item is “8a”, so answer space (A) has been blackened.

7. If you want to change your answer, erase your old answer completely and fill in your new choice.
8. When you are told to begin, turn the page and work as quickly and as carefully as you can. If you cannot Answer an item, omit it and go on to the next one. You can return later to the item omitted. Your score will be the total number of correct answers.
9. You may do any rough work in the booklet.
10. Do not be concerned that the answer sheet provides spaces for more answers than there are items in this test.

**DO NOT TURN THIS PAGE UNTIL YOU ARE TOLD TO DO SO.**

Copyright © 2003 Caribbean Examinations Council ®.

**LIST OF FORMULAE**

- Volume of a prism  $V = Ah$  where  $A$  is the area of a cross-section and  $h$  is the perpendicular length.
- Volume of a cylinder  $V = \pi r^2 h$  where  $r$  is the radius of the base and  $h$  is the perpendicular height.
- Volume of a right pyramid  $V = \frac{1}{3} Ah$  where  $A$  is the area of the base and  $h$  is the perpendicular height.
- Circumference  $C = 2\pi r$  where  $r$  is the radius of the circle.
- Area of a circle  $A = \pi r^2$  where  $r$  is the radius of the circle.
- Area of Trapezium  $A = \frac{1}{2}(a + b)h$  where  $a$  and  $b$  are the lengths of the parallel sides and  $h$  is the perpendicular distance between the parallel sides.
- Roots of quadratic equations If  $ax^2 + bx + c = 0$ ,

$$\text{then } x = \frac{-b \pm \sqrt{b^2 - 4ac}}{2a}$$

- Trigonometric ratios
- $$\sin \theta = \frac{\text{opposite side}}{\text{hypotenuse}}$$
- $$\cos \theta = \frac{\text{adjacent side}}{\text{hypotenuse}}$$
- $$\tan \theta = \frac{\text{opposite side}}{\text{adjacent side}}$$

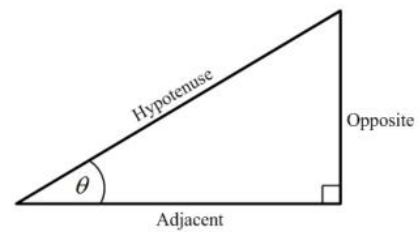

- Area of triangle Area of  $\Delta = \frac{1}{2}bh$  where  $b$  is the length of the base and  $h$  is the perpendicular height

$$\text{Area of } \Delta ABC = \frac{1}{2}ab \sin C$$

$$\text{Area of } \Delta ABC = \sqrt{s(s-a)(s-b)(s-c)}$$

$$\text{where } s = \frac{a+b+c}{2}$$

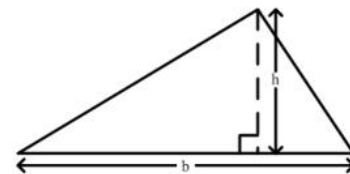

- Sine rule  $\frac{a}{\sin A} = \frac{b}{\sin B} = \frac{c}{\sin C}$

- Cosine rule  $a^2 = b^2 + c^2 - 2bc \cos A$

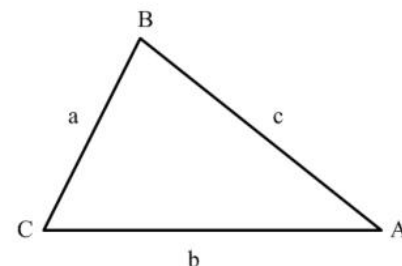

1. 0.0346 written in standard form is
- (A)  $3.46 \times 10^2$   
(B)  $3.46 \times 10$   
(C)  $3.46 \times 10^{-1}$   
(D)  $3.46 \times 10^{-2}$
2.  $3.3 \times 2.5 + 5.7 \times 2.5 =$
- (A) 8.25  
(B) 9.00  
(C) 13.25  
(D) 22.50
3.  $\sqrt{17^2 - 15^2}$
- (A) 16  
(B) 8  
(C) 2  
(D) 1
4. The ratio of two numbers is 4 : 5. The smaller number is 240. What is the larger number?
- (A) 133  
(B) 192  
(C) 300  
(D) 720
5. A clock costing £210.00 in the U.K. is exported to Trinidad. The rate of exchange is U.K. £1.00 = TT \$3.40. How much will the clock be worth in Trinidad
- (A) \$ 61.66  
(B) \$ 71.40  
(C) \$617.60  
(D) \$714.00
6. John, Peter and Mary shared a sum of money in the ratio 2:4:9. John and Peter together received \$360. How much money in all was shared ?
- (A) \$ 900  
(B) \$ 600  
(C) \$ 540  
(D) \$ 480
7. What is the value of the digit 3 in the number 2341?
- (A) 3  
(B) 30  
(C) 300  
(D) 3000
8.  $500_{\text{eight}}$  written in base ten is the same as
- (A)  $5 \times 8^3$   
(B)  $5 \times 8^2$   
(C)  $5 \times 8$   
(D)  $5 \times 8^0$
9.  $25 \times 130$  is the same as
- (A)  $(25 \times 100) + 30$   
(B)  $(25 + 30) \times 100$   
(C)  $(25 \times 30) + (25 \times 100)$   
(D)  $(100 \times 30) + (100 \times 25)$
10. If  $p = 3(a - q)$ , then  $6a$  is equal to
- (A)  $2(p + 3q)$   
(B)  $2(p + q)$   
(C)  $p + 3q$   
(D)  $p + q$

11. Which of the following sets is equivalent to  $\{a, b, c, d\}$ ?

- (A)  $\{4\}$
- (B)  $\{a, b, c\}$
- (C)  $\{p, q, r, s\}$
- (D)  $\{1, 2, 3, 4, 5\}$

12.

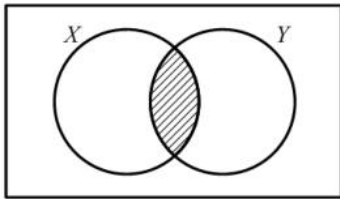

In the figure above,  $X$  represents the set of multiples of four.  $Y$  represents the set of multiples of 5. The shaded region is the set of all multiples of

- (A) 8
- (B) 9
- (C) 10
- (D) 20

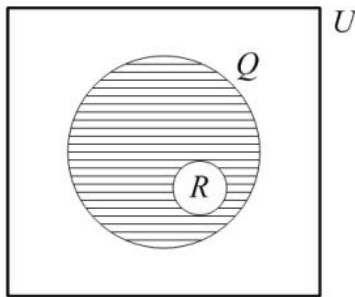

13. In the Venn diagram above, the shaded region represents

- (A)  $Q'$
- (B)  $R'$
- (C)  $Q' \cap R$
- (D)  $Q \cap R'$

14. Of a class of 32 students, 17 study Music and 20 study Art. What is the LEAST number of students who could study BOTH Music and ART?

- (A) 3
- (B) 5
- (C) 12
- (D) 15

15. The simple interest on \$400 at 5% per annum for 2 years is given by

- (A)  $\$ \frac{400 \times 5 \times 2}{100}$
- (B)  $\$ \frac{400 \times 5}{2 \times 100}$
- (C)  $\$ \frac{400 \times 2}{5 \times 100}$
- (D)  $\$ \frac{400 \times 100}{2 \times 5}$

16. The cost price of a refrigerator is \$1850.00. A buyer who is given a discount of 5% for cash purchase will pay

- (A) \$1942.50
- (B) \$1845.00
- (C) \$1757.50
- (D) \$1350.00

17. A plot of land is valued at \$18000. Land tax is charged at the rate of \$0.70 per \$100. What is total amount of tax to be paid for the land?

- (A) \$110.00
- (B) \$126.00
- (C) \$180.70
- (D) \$257.15

Item 18 refers to the following table.

Mark	0	1	2	3	4	5	6	7	8	9
No. of students	5	2	3	4	6	8	8	4	9	1

18. The table above shows the marks obtained by 50 students in a test. What is the probability that a student chosen at random has a mark less than 5?
- (A)  $\frac{2}{5}$   
 (B)  $\frac{3}{5}$   
 (C)  $\frac{11}{25}$   
 (D)  $\frac{14}{25}$
19. An article bought for \$125 was sold for \$175. The percentage profit was
- (A) 28.6  
 (B) 40  
 (C) 50  
 (D) 71.4
20. A salesman is paid 5% of his sales as commission. He made sales of \$2020. How much commission was he paid?
- (A) \$ 11.00  
 (B) \$ 20.20  
 (C) \$101.00  
 (D) \$110.00
21. Mary invested \$200 for 3 years at 5% per annum. John invested \$300 at the same rate. If they both received the same amount of money in interest, for how many years did John invest his money?
- (A)  $1\frac{1}{2}$   
 (B) 2  
 (C) 3  
 (D) 10
22. An article costs \$161. If a profit of 13% is to be made on the cost price, the selling price, in dollars, is
- (A)  $161(1 + \frac{13}{100})$   
 (B)  $13(1 + \frac{161}{100})$   
 (C)  $161(13 + \frac{1}{100})$   
 (D)  $13(161 + \frac{1}{100})$
23. After a 20% increase an article costs \$270. The original cost of the article is
- (A) \$216  
 (B) \$225  
 (C) \$250  
 (D) \$324
24. If  $\frac{p}{5} = 20$ , the  $p =$
- (A)  $20 - 5$   
 (B)  $20 + 5$   
 (C)  $20 \div 5$   
 (D)  $20 \times 5$

25. 'y is equal to the square of x' can be written as

- (A)  $y^2 = x$
- (B)  $y = x^2$
- (C)  $y = 2x$
- (D)  $y = 2 + x$

26. Given that  $a * b = 2a - 3b$ , then  $2 * (-3) =$

- (A) 13
- (B) 3
- (C) -5
- (D) -7

27.  $(-8a) \times (-3b) =$

- (A)  $-24ab$
- (B)  $-11ab$
- (C)  $11ab$
- (D)  $24ab$

28.  $3x^2 \times 2x^3 =$

- (A)  $6x^5$
- (B)  $6x^6$
- (C)  $5x^6$
- (D)  $72x^5$

29. If the set  $A = \{-2, 1, 3\}$ , then the set A is a subset of the set of

- (A) natural numbers
- (B) irrational numbers
- (C) whole numbers
- (D) integers

30. When 8 is subtracted from a certain number and the result is multiplied by 3 the final answer is 21. What is the original number?

- (A) 1
- (B) 3
- (C) 10
- (D) 15

31. Given that  $3 * 6 = 12$  and  $2 * 5 = 9$ , then  $a * b$  may be defined as

- (A)  $4(b - a)$
- (B)  $a^2 + b$
- (C)  $6a - b$
- (D)  $2a + b$

32.

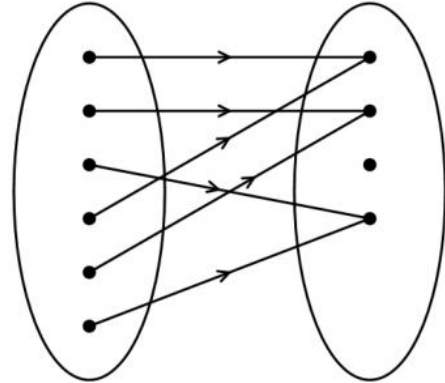

The relationship that BEST describes the mapping in the above diagram is

- (A) one-to-one
- (B) one-to-many
- (C) many-to-one
- (D) many-to-many

33. A man used 20 percent of his land for growing oranges, 65 percent for mangoes and the remainder for avocados. On a pie chart, what is the angle of the sector representing avocados?

- (A)  $306^\circ$
- (B)  $85^\circ$
- (C)  $54^\circ$
- (D)  $15^\circ$

34. Which of the following does NOT represent the graph of a function?

(A)

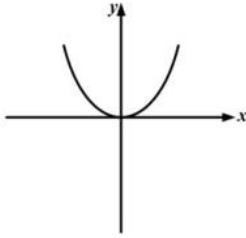

(B)

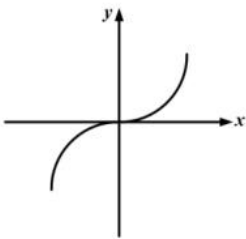

(C)

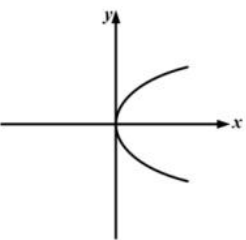

(D)

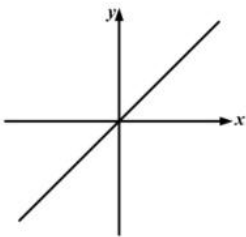

35. Which of the following sets of ordered pairs describes a function?

(A)  $\{(2, 3), (2, 5), (4, 7)\}$

(B)  $\{(2, 1), (4, 3), (5, 7)\}$

(C)  $\{(3, -2), (2, 4), (3, 6)\}$

(D)  $\{(-1, 4), (-1, 5), (2, 5)\}$

Item 36 refers to the following diagram.

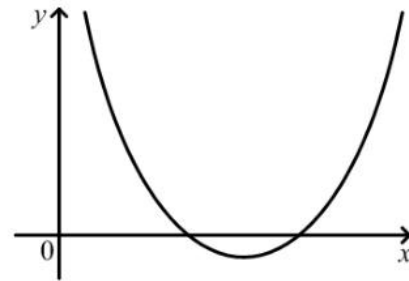

36. The diagram above shows a graph. If  $a$ ,  $b$  and  $c$  are positive constants, the equation of the graph is

(A)  $y = ax^2 + c$

(B)  $y = c - ax^2$

(C)  $y = ax^2 + bx + c$

(D)  $y = c + bx - ax^2$

37.

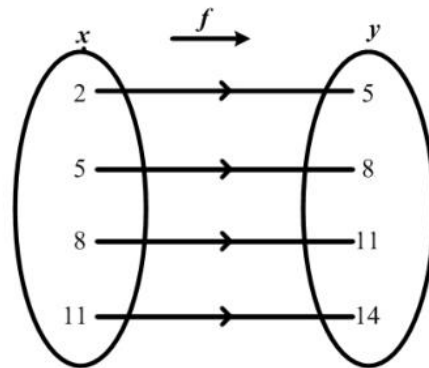

The arrow diagram above shows a function. Which of the following BEST describes the function?

(A)  $f(x) = x + 3$

(B)  $f(x) = y + 3$

(C)  $x = y + 3$

(D)  $y = x$

38.

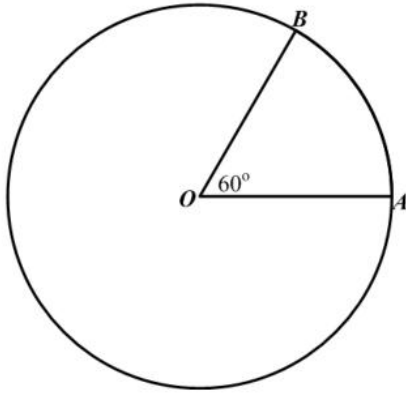

$O$  is the centre of the circle above. The area of the circle is  $20 \text{ cm}^2$ . The area of the minor sector  $AOB$ , in  $\text{cm}^2$ , is

- (A)  $\frac{1}{60} \times 20$   
 (B)  $\frac{60}{360} \times 20$   
 (C)  $\left(\frac{360 - 60}{360}\right) \times 20$   
 (D)  $60 \times 20$

39. The volume of a cube of sides 10 cm is

- (A)  $30 \text{ cm}^3$   
 (B)  $100 \text{ cm}^3$   
 (C)  $300 \text{ cm}^3$   
 (D)  $1000 \text{ cm}^3$

40. If it took a speed-boat 9 hours to travel a distance of 1080 km, what was its average speed?

- (A) 12 km/h  
 (B) 102 km/h  
 (C) 120 km/h  
 (D) 1200 km/h

41. The distance around the edge of a circular pond is 88 m. The radius, in metres is

- (A)  $88\pi$   
 (B)  $176\pi$   
 (C)  $\frac{88}{\pi}$   
 (D)  $\frac{88}{2\pi}$

42. A school day starts at 08:50 hrs. and ends at 15:00 hrs. There are two breaks. One lasting 20 minutes and the other 1 hour. How much time is devoted to school activities?

- (A) 2 hrs. 30 mins.  
 (B) 4 hrs. 30 mins.  
 (C) 5 hrs. 30 mins.  
 (D) 6 hrs. 10 mins.

43. On leaving Trinidad, the time on a pilot's watch was 23:00 hrs. When he arrived at his destination in the same time zone, on the following day, his watch showed 03:00 hrs. How many hours did the flight take?

- (A) 4  
 (B) 20  
 (C) 26  
 (D) 52

44.

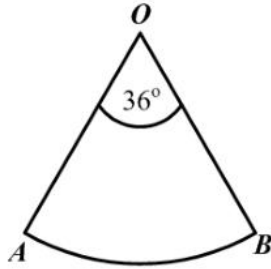

In the figure above,  $O$  is the centre of a circle of radius 10 cm and angle  $AOB$  is  $36^\circ$ . What is the length, in cm, of the arc  $AB$ ?

- (A)  $2\pi$
- (B)  $4\pi$
- (C)  $20\pi$
- (D)  $24\pi$

45.

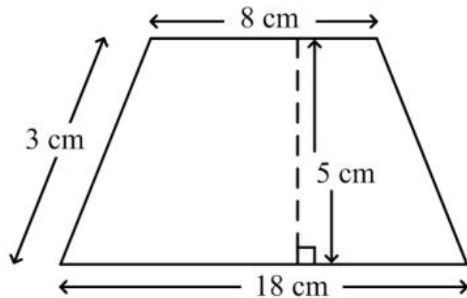

The area of the trapezium above is

- (A)  $45 \text{ cm}^2$
- (B)  $65 \text{ cm}^2$
- (C)  $90 \text{ cm}^2$
- (D)  $130 \text{ cm}^2$

46. Which of the following is NOT a statistical diagram?

- (A) Bar graph
- (B) Pie chart
- (C) Frequency polygon
- (D) Modal class

Item 47 refers to the bar chart below which shows the ages of children who took part in a survey.

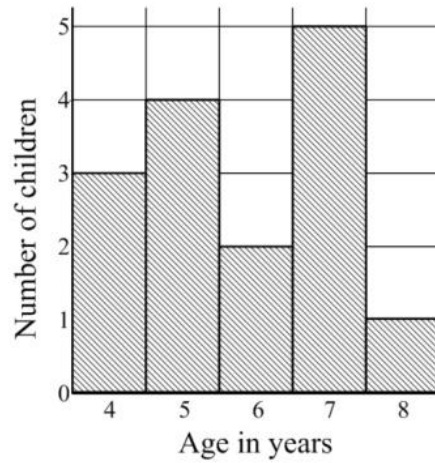

47. How many children took part in the survey?

- (A) 87
- (B) 75
- (C) 15
- (D) 5

48. Tony obtained the following scores in a game.

7 3 8 4 5 6 9 8 9

The median score is

- (A) 6
- (B) 7
- (C) 8
- (D) 9

49. A bag contains 2 red , 4 yellow and 6 blue balls. The probability of drawing a **blue** ball from the bag at random is

- (A)  $\frac{1}{6}$
- (B)  $\frac{1}{3}$
- (C)  $\frac{1}{2}$
- (D)  $\frac{6}{11}$

50.

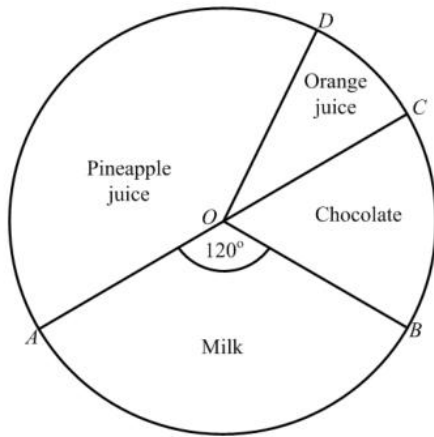

The pie chart above shows the preference in drinks of a group of students. If 12 students prefer chocolate, then the total number of students is

- (A) 48
- (B) 72
- (C) 180
- (D) 360

51. A boy throws a die twice. What is the probability that he will get a three followed by an even number?

- (A)  $\frac{1}{12}$
- (B)  $\frac{1}{4}$
- (C)  $\frac{5}{12}$
- (D)  $\frac{7}{12}$

52. If the sum of the interior angles of a polygon is 4 right angles, the polygon is a

- (A) triangle
- (B) quadrilateral
- (C) pentagon
- (D) hexagon

53. Which of the following is NOT a quadrilateral?

- (A) Parallelogram
- (B) Rhombus
- (C) Square
- (D) Pentagon

54.

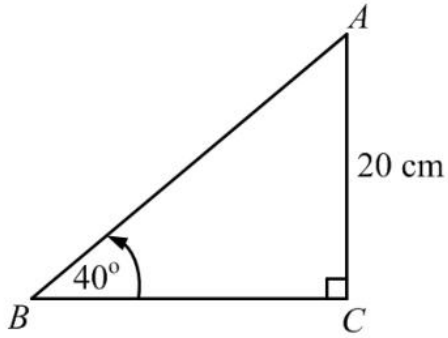

The triangle  $ABC$  above is right-angled at  $C$ .

$\hat{A}BC = 40^\circ$  and  $AC = 20\text{ cm}$ . The length of  $BC$ , in cm, is

- (A)  $\frac{20}{\tan 40^\circ}$
- (B)  $\frac{20}{\sin 40^\circ}$
- (C)  $20 \sin 40^\circ$
- (D)  $20 \tan 40^\circ$

55.

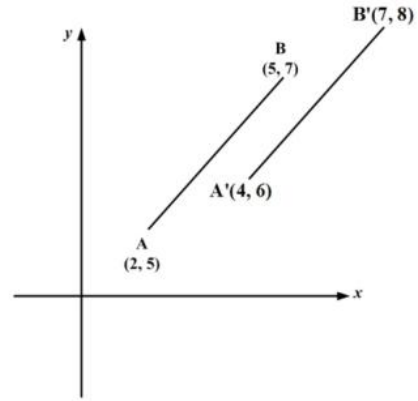

55. In the diagram above the translation in which  $AB$  is mapped onto  $A'B'$  is represented by

- (A)  $\begin{pmatrix} 1 \\ 1 \end{pmatrix}$
- (B)  $\begin{pmatrix} 2 \\ 1 \end{pmatrix}$
- (C)  $\begin{pmatrix} 3 \\ 2 \end{pmatrix}$
- (D)  $\begin{pmatrix} 5 \\ 3 \end{pmatrix}$

56.

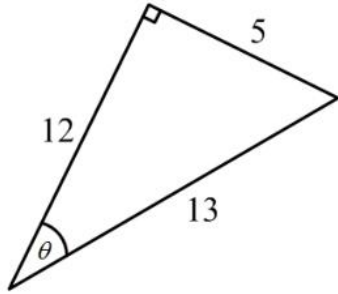

In the right-angled triangle above,  $\tan \theta$  is

- (A)  $\frac{5}{13}$
- (B)  $\frac{5}{12}$
- (C)  $\frac{12}{5}$
- (D)  $\frac{13}{5}$

57.

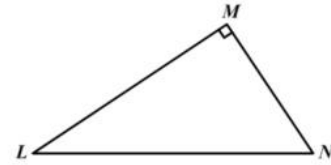

The triangle  $LMN$  above is rotated in a clockwise direction about  $L$  through an angle of  $90^\circ$ . What is its image?

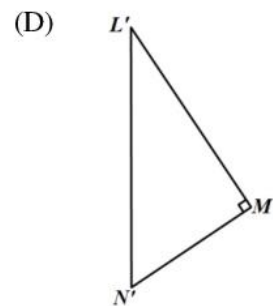
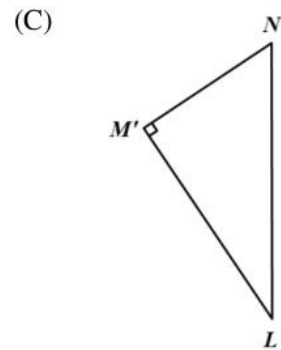
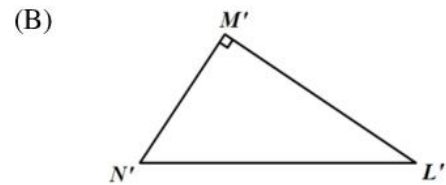
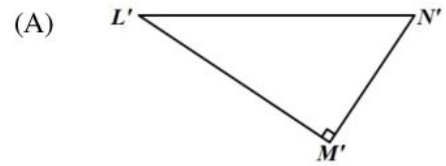

58.

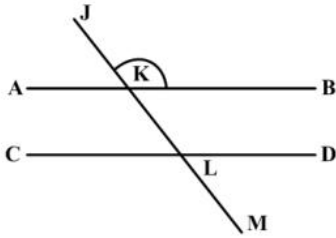

In the figure above,  $AB$  is parallel to  $CD$ , and  $\angle JKB = 125^\circ$ .

$\angle MLD$  is

- (A)  $125^\circ$
- (B)  $90^\circ$
- (C)  $55^\circ$
- (D)  $45^\circ$

59.

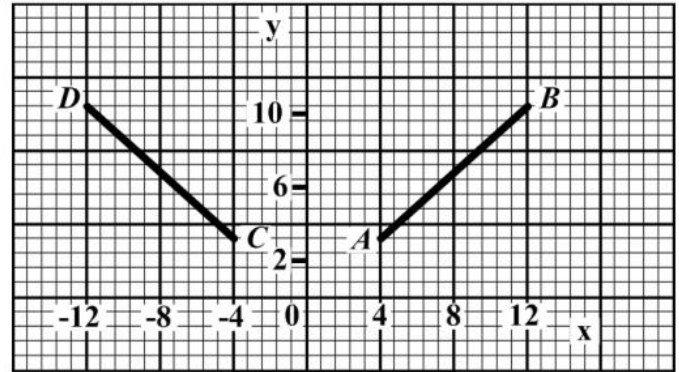

In the figure above, the line  $CD$  is the image of  $AB$  after a/an

- (A) reflection in the  $y$ -axis
- (B) rotation through  $90^\circ$  centre  $O$
- (C) enlargement of scale factor  $-1$
- (D) translation by vector  $\begin{pmatrix} -4 \\ -8 \end{pmatrix}$

60. A plane is travelling in a direction of  $045^\circ$  and changes course in a clockwise direction to  $135^\circ$ . The angle through which the plane turned is

- (A)  $45^\circ$
- (B)  $90^\circ$
- (C)  $135^\circ$
- (D)  $270^\circ$

**IF YOU FINISH BEFORE TIME IS CALLED, CHECK YOUR WORK ON THIS TEST.**



↑ AFFIX SEAL HERE ↑

**CANDIDATE –PLEASE NOTE!**

You must sign below and return this booklet with the Answer Sheet. Failure to do so may result in disqualification.

\_\_\_\_\_  
SignatureTEST CODE **01234010**

MAY/JUNE 2005

**FORM TP 2007104**

**CARIBBEAN EXAMINATIONS COUNCIL**  
**SECONDARY EDUCATION CERTIFICATE**  
**EXAMINATION**  
**MATHEMATICS**  
**Paper 01 – General Proficiency**  
*90 minutes*

26 MAY 2005 (p.m.)

**READ THE FOLLOWING DIRECTIONS CAREFULLY**

1. In addition to this test booklet, you should have an answer sheet.
2. Calculators and mathematical tables may NOT be used for this paper.
3. **A list of formulae is provided on page 2 of this booklet.**
4. This test consists of 60 items. You will have 90 minutes to answer them.
5. Each item in this test has four suggested answers, lettered (A), (B), (C), (D). Read each item you are about to answer, and decide which choice is best.
6. On your answer sheet, find the number which corresponds to your item and blacken the space having the same letter as the answer you have chosen. Look at the sample item below.

Sample Item

$2a + 6a =$

- (A)  $8a$   
 (B)  $8a^2$   
 (C)  $12a$   
 (D)  $12a^2$

Sample Answer

The best answer to this item is “ $8a$ ”, so answer space (A) has been blackened.

7. If you want to change your answer, erase your old answer completely and fill in your new choice.
8. When you are told to begin, turn the page and work as quickly and as carefully as you can. If you cannot Answer an item, omit it and go on to the next one. You can return later to the item omitted. Your score will be the total number of correct answers.
9. You may do any rough work in the booklet.
10. Do not be concerned that the answer sheet provides spaces for more answers than there are items in this test.

**DO NOT TURN THIS PAGE UNTIL YOU ARE TOLD TO DO SO.**

Copyright © 2004 Caribbean Examinations Council ®.

**LIST OF FORMULAE**

Volume of a prism  $V = Ah$  where  $A$  is the area of a cross-section and  $h$  is the perpendicular length.

Volume of a cylinder  $V = \pi r^2 h$  where  $r$  is the radius of the base and  $h$  is the perpendicular height.

Volume of a right pyramid  $V = \frac{1}{3} Ah$  where  $A$  is the area of the base and  $h$  is the perpendicular height.

Circumference  $C = 2\pi r$  where  $r$  is the radius of the circle.

Area of a circle  $A = \pi r^2$  where  $r$  is the radius of the circle.

Area of Trapezium  $A = \frac{1}{2}(a + b)h$  where  $a$  and  $b$  are the lengths of the parallel sides and  $h$  is the perpendicular distance between the parallel sides.

Roots of quadratic equations If  $ax^2 + bx + c = 0$ ,  
 then  $x = \frac{-b \pm \sqrt{b^2 - 4ac}}{2a}$

Trigonometric ratios

$$\sin \theta = \frac{\text{opposite side}}{\text{hypotenuse}}$$

$$\cos \theta = \frac{\text{adjacent side}}{\text{hypotenuse}}$$

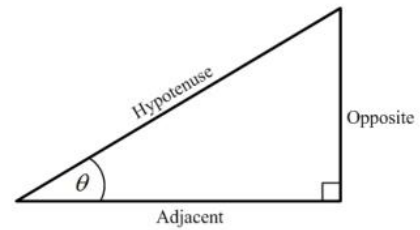
$$\tan \theta = \frac{\text{opposite side}}{\text{adjacent side}}$$

Area of triangle Area of  $\Delta = \frac{1}{2}bh$  where  $b$  is the length of the base and  $h$  is the perpendicular height

$$\text{Area of } \Delta ABC = \frac{1}{2}ab \sin C$$

$$\text{Area of } \Delta ABC = \sqrt{s(s-a)(s-b)(s-c)}$$

$$\text{where } s = \frac{a+b+c}{2}$$

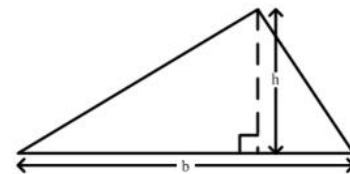

Sine rule  $\frac{a}{\sin A} = \frac{b}{\sin B} = \frac{c}{\sin C}$

Cosine rule  $a^2 = b^2 + c^2 - 2bc \cos A$

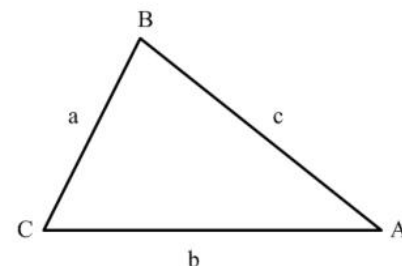

1. 0.875 written as a common fraction is
- (A)  $\frac{1}{4}$   
(B)  $\frac{1}{2}$   
(C)  $\frac{3}{4}$   
(D)  $\frac{7}{8}$
2. The number 3.14063 written correct to 3 decimal places is
- (A) 3.140  
(B) 3.141  
(C) 3.146  
(D) 3.150
3. The EXACT value of  $2 \div (0.01)^2$  is
- (A) 0.0002  
(B) 0.0005  
(C) 5000  
(D) 20000
4.  $0.386 \times 0.06 =$
- (A) 0.02316  
(B) 0.2316  
(C) 2.313  
(D) 23.16
5. If \$350 is divided into two portions in the ratio 2 : 5, the smaller portion is
- (A) \$ 70  
(B) \$100  
(C) \$175  
(D) \$250
6. If 60% of a number is 90, what is the number?
- (A) 30  
(B) 54  
(C) 150  
(D) 180
7. The H.C.F. of 12, 15 and 60 is
- (A) 1  
(B) 3  
(C) 12  
(D) 60
8. The value of the digit 2 in 425.3 is
- (A) 2 tenths  
(B) 2 ones  
(C) 2 tens  
(D) 2 hundreds
9.  $99 \times 101$  is the same as
- (A)  $(99 \times 100) + 1$   
(B)  $(99 \times 100) - (99 \times 1)$   
(C)  $(99 \times 100) + (99 \times 1)$   
(D)  $(99 \times 100)(99 \times 1)$
10. What is the least number of plums that can be shared equally among 6, 9 or 12 children?
- (A) 27  
(B) 36  
(C) 54  
(D) 72

11. If  $P = \{2, 3, 5, 7\}$ ,  $Q = \{2, 3, 6\}$  and  $S = \{2, 4, 5\}$ , then  $P \cap Q \cap S =$
- (A)  $\{ \}$   
 (B)  $\{ 2 \}$   
 (C)  $\{ 2, 3 \}$   
 (D)  $\{ 2, 3, 4, 5, 6, 7 \}$

12.  $U = \{ \text{Integers} \}$   
 $P = \{ \text{Positive Integers} \}$   
 $N = \{ \text{Negative Integers} \}$

Which of the Venn diagrams below illustrates the statement:

“No positive integers are negative integers” ?

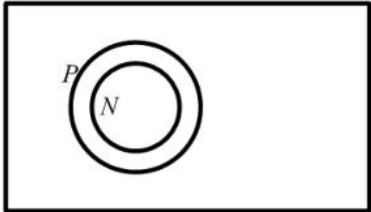
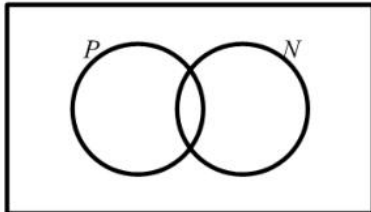
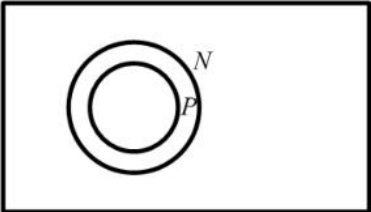
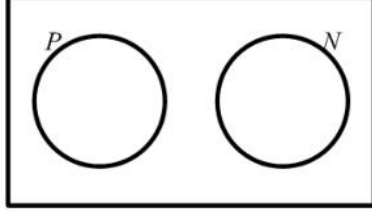
- (A) 
- (B) 
- (C) 
- (D) 

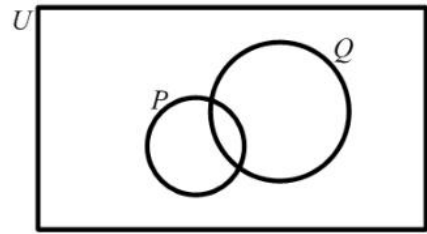

In the Venn diagram above,  $n(P) = 5$ ,  $n(Q) = 9$  and  $n(P \cup Q) = 10$ .

What is  $n(P \cap Q)$  ?

- (A) 4  
 (B) 6  
 (C) 14  
 (D) 24

14.

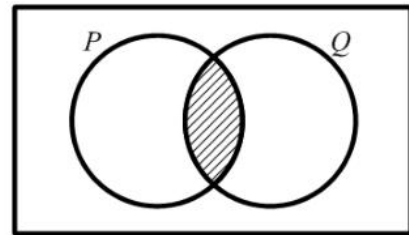

The two circles above represent set  $P$  and set  $Q$ . If  $P = \{ \text{Factors of 6} \}$  and  $Q = \{ \text{Factors of 4} \}$ , then the shaded region represents

- (A)  $\{ \}$   
 (B)  $\{ 1, 2 \}$   
 (C)  $\{ 4, 6, 8, \dots \}$   
 (D)  $\{ 12, 24, 36, \dots \}$

15. The simple interest on \$400 at 5% per annum for 2 years is given by
- (A)  $\$ \frac{400 \times 5 \times 2}{100}$   
 (B)  $\$ \frac{400 \times 5}{2 \times 100}$   
 (C)  $\$ \frac{400 \times 2}{5 \times 100}$   
 (D)  $\$ \frac{400 \times 100}{2 \times 5}$
16. A man bought a calf for \$200 and sold it for \$250. What was his gain as a percentage of the cost price?
- (A) 5%  
 (B) 15%  
 (C) 20%  
 (D) 25%
17. The sum of  $\frac{1}{2}$  and  $\frac{1}{3}$  is
- (A)  $\frac{2}{5}$   
 (B)  $\frac{3}{5}$   
 (C)  $\frac{5}{6}$   
 (D)  $\frac{7}{6}$
18. A salesman is paid 5% of his sales as commission. His sales for last month were \$2020. How much commission was he paid?
- (A) \$ 11.00  
 (B) \$ 20.20  
 (C) \$101.00  
 (D) \$110.00
19. How much does a customer pay for an article marked at \$50.00 if a sales tax of 6% is charged?
- (A) \$56.00  
 (B) \$53.00  
 (C) \$47.00  
 (D) \$44.00
20. The exchange rate for one United States dollar (US\$1.00) is two dollars and seventy cents in Eastern Caribbean currency (EC\$2.70). What is the value of US\$4.50 in EC currency?
- (A) \$ 1.67  
 (B) \$ 6.00  
 (C) \$ 7.20  
 (D) \$12.15
21. If the simple interest on \$800 for 3 years is \$54. What is the rate of interest per annum?
- (A) 44%  
 (B) 5%  
 (C)  $2\frac{1}{4}\%$   
 (D)  $\frac{4}{9}\%$
22. Mary invested \$200 for 3 years at 5% per annum. John invested \$300 at the same rate. If they both received the same amount of money in interest, for how many years did John invest his money?
- (A)  $1\frac{1}{2}$   
 (B) 2  
 (C) 3  
 (D) 10

23.  $(8a)^2 =$

- (A)  $16a$   
 (B)  $64a$   
 (C)  $16a^2$   
 (D)  $64a^2$

24.  $(-8a) \times (-3b) =$

- (A)  $-24ab$   
 (B)  $-11ab$   
 (C)  $11ab$   
 (D)  $24ab$

25.  $5(2x - y) - 2(3y - 5x) =$

- (A)  $-11y$   
 (B)  $2x - 6y$   
 (C)  $6x - 7y$   
 (D)  $20x - 11y$

26.  $3x^2 \times 2x^3 =$

- (A)  $6x^5$   
 (B)  $5x^5$   
 (C)  $6x^6$   
 (D)  $72x^5$

27. If  $m * n = \sqrt{mn - n^2}$ , then  $5 * 3 =$

- (A)  $\sqrt{6}$   
 (B)  $3$   
 (C)  $\sqrt{15}$   
 (D)  $6$

28. If  $50 - 3x = x - 26$ , then  $x =$

- (A)  $-12$   
 (B)  $-6$   
 (C)  $6$   
 (D)  $19$

29. If  $P = \frac{m^2}{2-m}$ , when  $m = -3$ , then  $P =$

- (A)  $-6$   
 (B)  $\frac{-6}{5}$   
 (C)  $\frac{9}{5}$   
 (D)  $9$

30. Althea saves  $\$x$  each month; but in June she saved  $\$4$  more than twice her regular amount. In June she saved

- (A)  $\$4x$   
 (B)  $\$6x$   
 (C)  $\$(x+4)$   
 (D)  $\$(2x+4)$

31.  $3a(a+2b) - b(2a-3b) =$

- (A)  $3a^2 - ab + 3b^2$   
 (B)  $3a^2 + 4ab + 3b^2$   
 (C)  $3a^2 + 4ab - 3b^2$   
 (D)  $3a^2 + 8ab - 3b^2$

32. Which of the following represents the equation of a straight line?

- (A)  $y = \frac{4}{x}$   
 (B)  $y = x^2 - 4$   
 (C)  $y = 2x + 3$   
 (D)  $y = x^2 + 2x - 5$

33. If  $f(x) = x^2 - x - 1$ , then  $f(-5) =$

- (A) 31
- (B) 29
- (C) 24
- (D) -31

34.

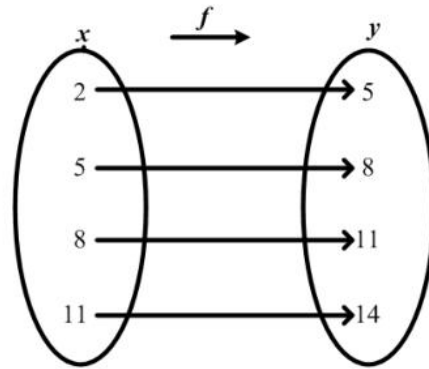

The arrow diagram above shows a function. Which of the following BEST describes the function?

- (A)  $f(x) = x + 3$
- (B)  $f(x) = y - 3$
- (C)  $x = y + 3$
- (D)  $y = x$

Item 35 refers to the graph below

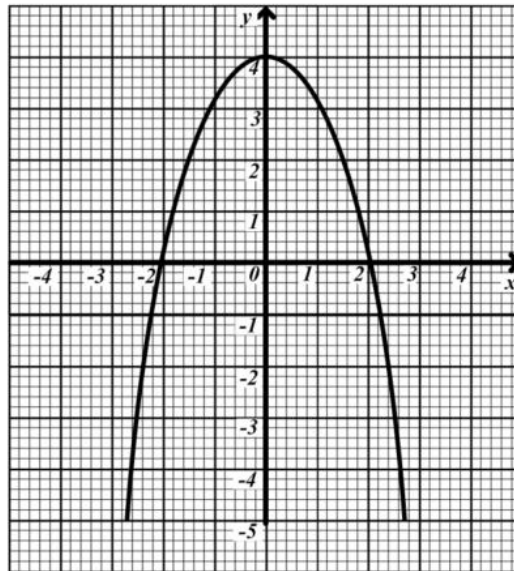

35. Using the graph above, the values of  $x$  when  $y = -1$  are

- (A) 1 and -1
- (B) 2.5 and -2.5
- (C) 2.8 and -2.8
- (D) 2.2 and -2.2

36. What is the gradient of the straight line  $2y = -3x - 8$ ?
- (A)  $-3$   
 (B)  $-\frac{3}{2}$   
 (C)  $2$   
 (D)  $3$

37. Which of the following does NOT represent the graph of a function?

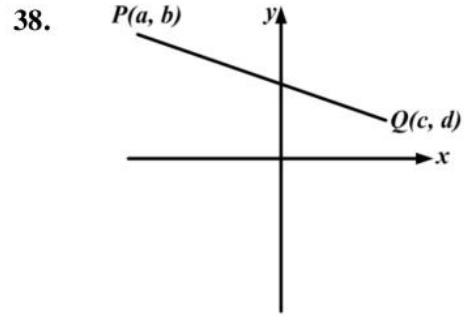
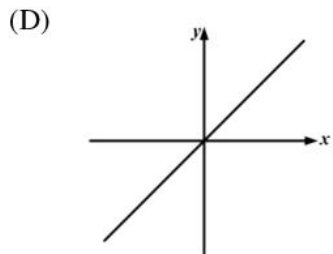
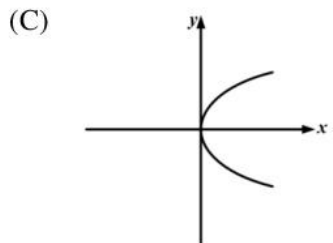
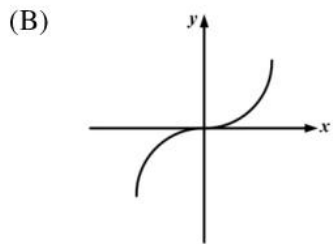
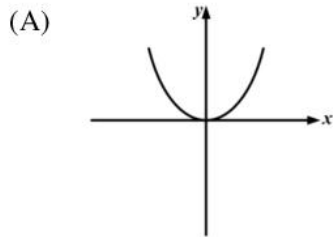

The diagram above shows the line  $PQ$ . The gradient of the line  $PQ$  is given by

- (A)  $\frac{b-d}{c-a}$   
 (B)  $\frac{c-a}{b-d}$   
 (C)  $\frac{a-c}{b-d}$   
 (D)  $\frac{b-d}{a-c}$

39. The volume of a cube of edge 10 cm is

- (A)  $30 \text{ cm}^3$   
 (B)  $100 \text{ cm}^3$   
 (C)  $300 \text{ cm}^3$   
 (D)  $1000 \text{ cm}^3$

40. How many kilometers will a car travel in  $t$  hours at a rate of  $v$  km per hour?
- (A)  $tv$   
 (B)  $\frac{v}{t}$   
 (C)  $\frac{t}{v}$   
 (D)  $\frac{v}{60t}$

41.

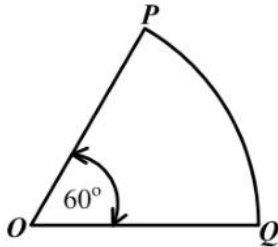

The figure above, not drawn to scale, shows a sector of a circle centre  $O$ . The length of the minor arc  $PQ$  is 8 cm. What is the length of the circumference of the circle?

- (A) 16 cm  
 (B) 24 cm  
 (C) 48 cm  
 (D) 64 cm
42. The distance around the edge of a circular pond is 88 m. The radius, in metres is
- (A)  $88\pi$   
 (B)  $176\pi$   
 (C)  $\frac{88}{\pi}$   
 (D)  $\frac{88}{2\pi}$

43. On leaving Trinidad, the time on a pilot's watch was 23:00 h. when he arrived at his destination in the same time zone, the next day, his watch showed 03:00 h. How many hours did the flight take?
- (A) 4  
 (B) 16  
 (C) 20  
 (D) 26

44. An aircraft leaves  $A$  at 16:00 h and arrives at  $B$  at 19:30 h, the same day, travelling at an average speed of 550 kilometers per hour.  $A$  and  $B$  are in the same time zone. The distance from  $A$  to  $B$  in kilometers is about
- (A) 907.5  
 (B) 962.5  
 (C) 1815  
 (D) 1925

45. A cylindrical bar of soap 5 cm thick has a volume of  $200 \text{ cm}^3$ . A uniform slice 3 cm thick is taken away. What volume of the soap remains?
- (A)  $80 \text{ cm}^3$   
 (B)  $120 \text{ cm}^3$   
 (C)  $300 \text{ cm}^3$   
 (D)  $400 \text{ cm}^3$

46.

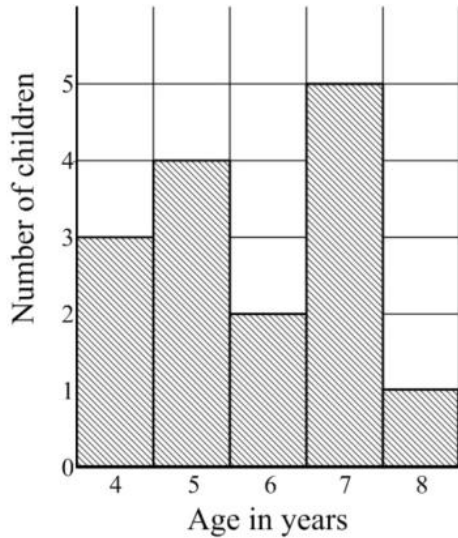

The bar chart above shows the ages of children who took part in a survey.

How many children took part in the survey?

- (A) 5
- (B) 15
- (C) 75
- (D) 87

47. Each of the letters in the word 'CHANCE' is written on a slip of paper and one slip is randomly drawn. What is the probability of drawing a letter 'C'?

- (A)  $\frac{1}{6}$
- (B)  $\frac{1}{5}$
- (C)  $\frac{1}{3}$
- (D)  $\frac{2}{3}$

48.

The highest weekly wage of a group of employees is \$105.40. If the range of the wages is \$27.50, how much does the lowest paid employee receive?

- (A) \$105.40
- (B) \$ 77.90
- (C) \$ 66.45
- (D) \$ 27.50

Item 49 refers to the following table.

Length of Leaf (cm)	10-14	15-19
Frequency	3	8

The lengths of 15 cabbage leaves were measured, to the nearest cm, and the information grouped as shown in the table above.

49.

The beginning and end points of the class interval 10 – 14 are

- (A) 9 and 14
- (B) 9.5 and 14
- (C) 9.5 and 14.5
- (D) 10 and 15

50.

A boy throws a die twice. What is the probability that he will get a '3' followed by an even number?

- (A)  $\frac{1}{12}$
- (B)  $\frac{1}{4}$
- (C)  $\frac{5}{12}$
- (D)  $\frac{7}{12}$

51.

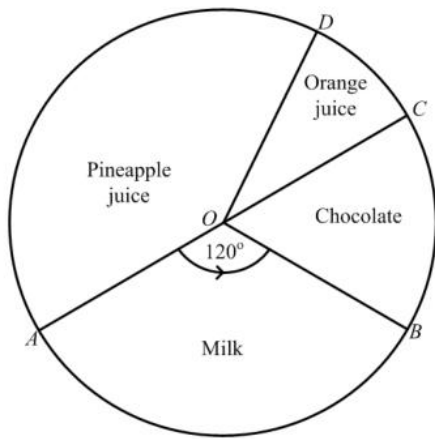

The pie chart above shows the preference in drinks of a group of students. If 12 students prefer chocolate, then the total number of students in the group is

- (A) 48
- (B) 72
- (C) 180
- (D) 360

Items 52-53 refer to the diagram below.

$AC$  and  $DE$  are straight lines intersecting at  $B$

Angle  $DBA = 58^\circ$

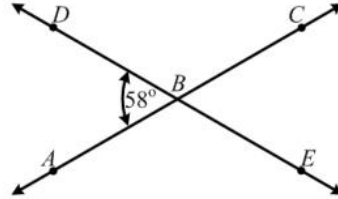

52. The measure of angle  $ABE$  is

- (A)  $302^\circ$
- (B)  $142^\circ$
- (C)  $122^\circ$
- (D)  $58^\circ$

53. Which of the following angles are equal?

- (A)  $\angle DBC$  and  $\angle CBE$
- (B)  $\angle CBE$  and  $\angle ABE$
- (C)  $\angle ABD$  and  $\angle CBD$
- (D)  $\angle ABD$  and  $\angle CBE$

54. Use the diagram below to answer item 54.

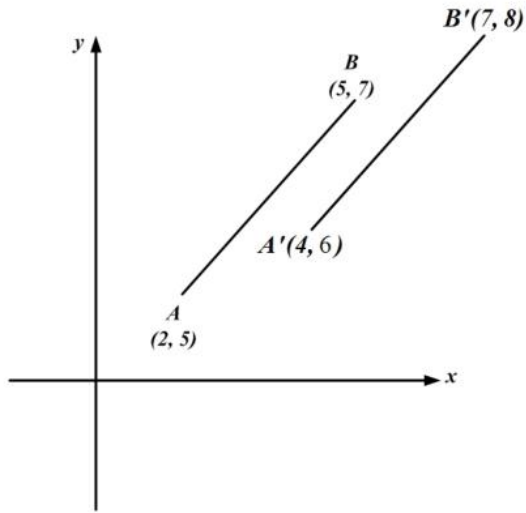

54. The translation by which  $AB$  is mapped to  $A'B'$  is represented by

- (A)  $\begin{pmatrix} 1 \\ 1 \end{pmatrix}$
- (B)  $\begin{pmatrix} 2 \\ 1 \end{pmatrix}$
- (C)  $\begin{pmatrix} 3 \\ 2 \end{pmatrix}$
- (D)  $\begin{pmatrix} 5 \\ 3 \end{pmatrix}$

55.

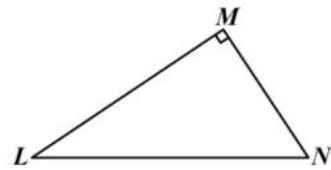

The triangle  $LMN$  above is rotated through an angle of  $90^\circ$  in a clockwise direction about  $L$ . What is its image?

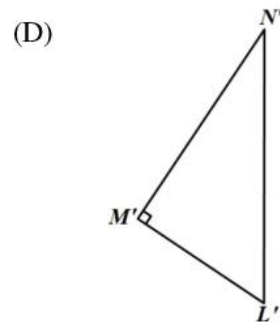
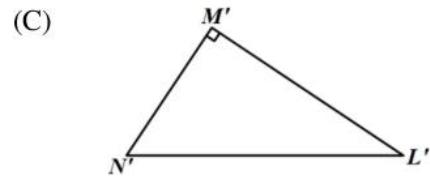
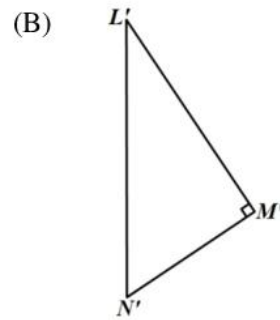
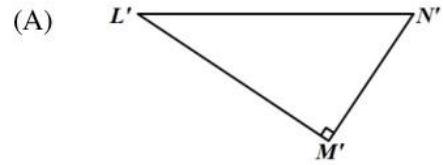

Item 56 refers to the graph below

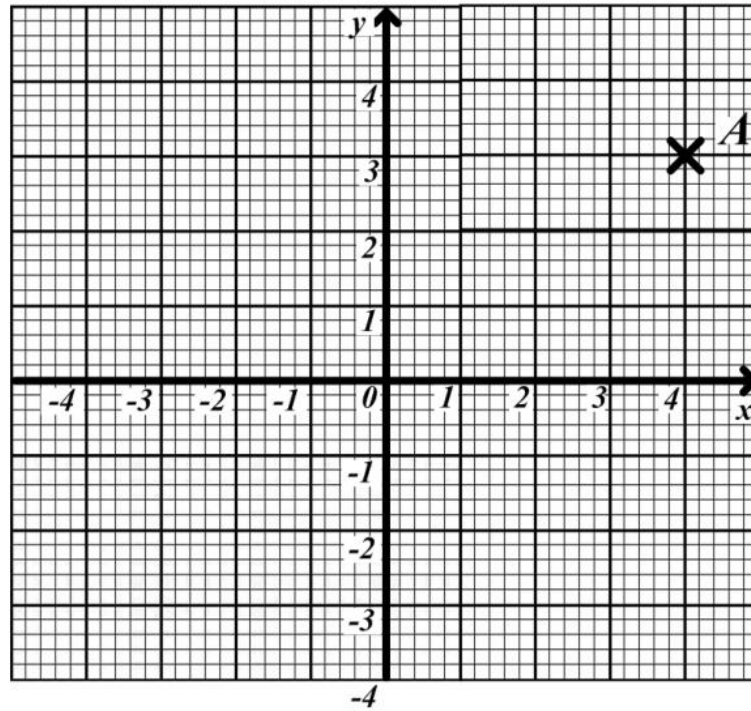

56. The point  $A$  is shown on the diagram above. What are the co-ordinates of the reflection of  $A$  in the  $y$ -axis?

- (A)  $(-4, 3)$
- (B)  $(4, -3)$
- (C)  $(3, -4)$
- (D)  $(-3, 4)$

Item 57 refers to the diagram below.

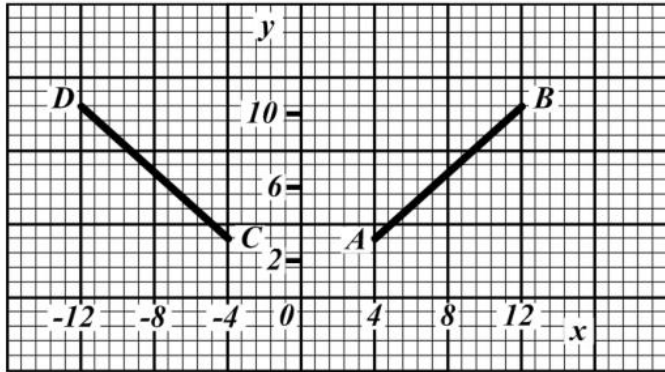

57. In the figure above, the line  $CD$  is the image of  $AB$  after a
- (A) a rotation through  $90^\circ$  centre  $O$
  - (B) an enlargement of scale factor  $-1$
  - (C) a translation by vector  $\begin{pmatrix} -4 \\ -8 \end{pmatrix}$
  - (D) a reflection in the  $y$ -axis

58.

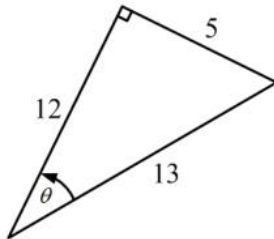

In the right-angled triangle above,  $\tan \theta$  is

- (A)  $\frac{5}{13}$
- (B)  $\frac{5}{12}$
- (C)  $\frac{12}{5}$
- (D)  $\frac{13}{5}$

59.

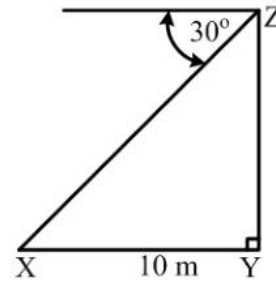

The diagram above, not drawn to scale, shows that the angle of depression of a point  $X$  from  $Z$  is  $30^\circ$ . If  $X$  is 10 metres from  $Y$ , the height of  $YZ$ , in metres, is

- (A)  $10 \sin 30^\circ$
  - (B)  $10 \tan 30^\circ$
  - (C)  $10 \cos 30^\circ$
  - (D)  $10 \cos 60^\circ$
60. In a triangle  $ABC$ , angle  $A = x^\circ$  and angle  $B = 2x^\circ$ . What is the size of angle  $C$ ?
- (A)  $45^\circ$
  - (B)  $60^\circ$
  - (C)  $(180 - 3x)^\circ$
  - (D)  $\left(\frac{180}{3x}\right)^\circ$

**IF YOU FINISH BEFORE TIME IS CALLED, CHECK YOUR WORK ON THIS TEST.**

↑ AFFIX SEAL HERE ↑

**CANDIDATE –PLEASE NOTE!**

You must sign below and return this booklet with the Answer Sheet. Failure to do so may result in disqualification.

\_\_\_\_\_  
SignatureTEST CODE **01234010**

JANUARY 2006

**FORM TP 2007104**

**C A R I B B E A N   E X A M I N A T I O N S   C O U N C I L**  
**S E C O N D A R Y   E D U C A T I O N   C E R T I F I C A T E**  
**E X A M I N A T I O N**  
**M A T H E M A T I C S**  
**P a p e r   0 1 – G e n e r a l   P r o f i c i e n c y**  
*9 0   m i n u t e s*

04 JANUARY 2006 (p.m.)

**READ THE FOLLOWING DIRECTIONS CAREFULLY**

1. In addition to this test booklet, you should have an answer sheet.
2. Calculators and mathematical tables may NOT be used for this paper.
3. **A list of formulae is provided on page 2 of this booklet.**
4. This test consists of 60 items. You will have 90 minutes to answer them.
5. Each item in this test has four suggested answers, lettered (A), (B), (C), (D). Read each item you are about to answer, and decide which choice is best.
6. On your answer sheet, find the number which corresponds to your item and blacken the space having the same letter as the answer you have chosen. Look at the sample item below.

Sample Item

$2a + 6a =$

- (A)  $8a$   
 (B)  $8a^2$   
 (C)  $12a$   
 (D)  $12a^2$

Sample Answer

The best answer to this item is “ $8a$ ”, so answer space (A) has been blackened.

7. If you want to change your answer, erase your old answer completely and fill in your new choice.
8. When you are told to begin, turn the page and work as quickly and as carefully as you can. If you cannot Answer an item, omit it and go on to the next one. You can return later to the item omitted. Your score will be the total number of correct answers.
9. You may do any rough work in the booklet.
10. Do not be concerned that the answer sheet provides spaces for more answers than there are items in this test.

**DO NOT TURN THIS PAGE UNTIL YOU ARE TOLD TO DO SO.**

Copyright © 2005 Caribbean Examinations Council ®.

**LIST OF FORMULAE**

- Volume of a prism  $V = Ah$  where  $A$  is the area of a cross-section and  $h$  is the perpendicular length.
- Volume of a cylinder  $V = \pi r^2 h$  where  $r$  is the radius of the base and  $h$  is the perpendicular height.
- Volume of a right pyramid  $V = \frac{1}{3}Ah$  where  $A$  is the area of the base and  $h$  is the perpendicular height.
- Circumference  $C = 2\pi r$  where  $r$  is the radius of the circle.
- Area of a circle  $A = \pi r^2$  where  $r$  is the radius of the circle.
- Area of Trapezium  $A = \frac{1}{2}(a + b)h$  where  $a$  and  $b$  are the lengths of the parallel sides and  $h$  is the perpendicular distance between the parallel sides.
- Roots of quadratic equations If  $ax^2 + bx + c = 0$ ,

$$\text{then } x = \frac{-b \pm \sqrt{b^2 - 4ac}}{2a}$$

- Trigonometric ratios
- $$\sin \theta = \frac{\text{opposite side}}{\text{hypotenuse}}$$
- $$\cos \theta = \frac{\text{adjacent side}}{\text{hypotenuse}}$$
- $$\tan \theta = \frac{\text{opposite side}}{\text{adjacent side}}$$

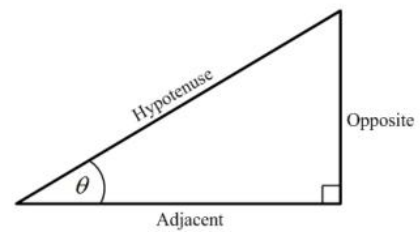

- Area of triangle Area of  $\Delta = \frac{1}{2}bh$  where  $b$  is the length of the base and  $h$  is the perpendicular height

$$\text{Area of } \Delta ABC = \frac{1}{2}ab \sin C$$

$$\text{Area of } \Delta ABC = \sqrt{s(s-a)(s-b)(s-c)}$$

$$\text{where } s = \frac{a+b+c}{2}$$

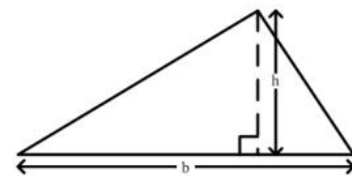

- Sine rule  $\frac{a}{\sin A} = \frac{b}{\sin B} = \frac{c}{\sin C}$

- Cosine rule  $a^2 = b^2 + c^2 - 2bc \cos A$

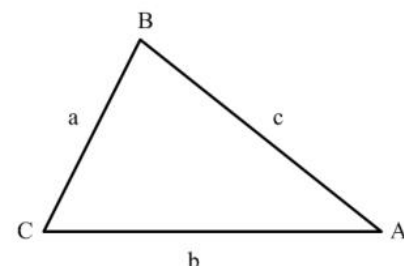

1.  $(-3)^2 + (-2)^2 =$
- (A) -13  
(B) -10  
(C) 13  
(D) 25
2.  $11.1 \div 0.01$
- (A) 110  
(B) 111  
(C) 1 100  
(D) 1 110
3. The number 3076 written in standard form is
- (A)  $3.076 \times 10^3$   
(B)  $3.076 \times 10^2$   
(C)  $3.076 \times 10^{-2}$   
(D)  $3.076 \times 10^{-3}$
4. If \$560 is shared in the ratio 2:3:9, the difference between the largest and the smallest shares is
- (A) \$ 80  
(B) \$240  
(C) \$280  
(D) \$360
5. In a school the ratio of the number of pupils to the number of teachers is 20 : 1. If the number of pupils is 840, how many teachers are there?
- (A) 40  
(B) 42  
(C) 800  
(D) 840
6. There are 40 students in a class. Girls make up 60% of the class. 25% of the girls wear glasses. How many girls in the class wear glasses?
- (A) 6  
(B) 8  
(C) 10  
(D) 15
7. A student used a rod to measure the distances 3.6m, 5.4m and 7.2m. What was the GREATEST length of the rod if it fitted each distance an exact number of times?
- (A) 0.9 m  
(B) 1.8 m  
(C) 2.7 m  
(D) 3.6 m
8. 301 can be written as
- (A)  $3 \times 10^3 + 1 \times 10$   
(B)  $3 \times 10^2 + 1 \times 10$   
(C)  $3 \times 10^3 + 1$   
(D)  $3 \times 10^2 + 1$
9.  $-\left(\frac{1}{2}\right)^3$  is the same as
- (A)  $-\frac{1}{8}$   
(B)  $-\frac{1}{6}$   
(C)  $\frac{1}{8}$   
(D)  $\frac{1}{6}$
10. By the distributive law  $49 \times 17 + 3 \times 49 =$
- (A)  $52 + 66$   
(B)  $52 \times 66$   
(C)  $49 + 20$   
(D)  $49 \times 20$

11. If  $P = \{a, b, c\}$  then the number of subsets of  $P$  is

- (A) 3
- (B) 4
- (C) 8
- (D) 16

Item 12 refers to the Venn diagram below.

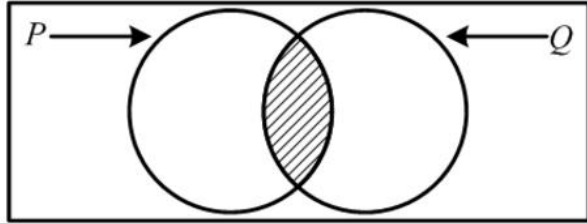

12. The two circles above represent set  $P$  and set  $Q$ . If  $P = \{\text{Factors of } 6\}$  and  $Q = \{\text{Factors of } 4\}$ , then the shaded region represents

- (A)  $\{ \}$
- (B)  $\{1, 2\}$
- (C)  $\{4, 6, 8, \dots\}$
- (D)  $\{12, 24, 36, \dots\}$

Item 13 refers to the Venn diagram below.

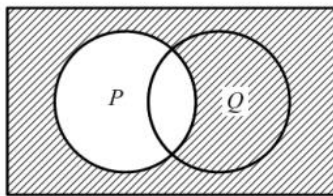

13. In the Venn diagram above, the shaded area represents

- (A)  $P'$
- (B)  $(P \cup Q)'$
- (C)  $Q \cap P'$
- (D)  $Q \cup P'$

14. In which one of the following Venn diagrams is the region  $A \cap B'$  shaded?

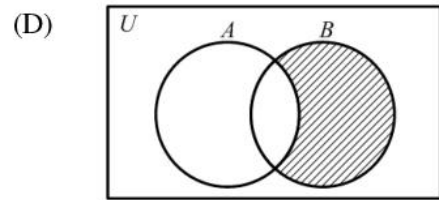
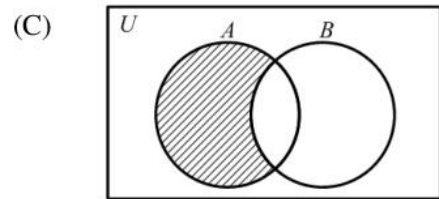
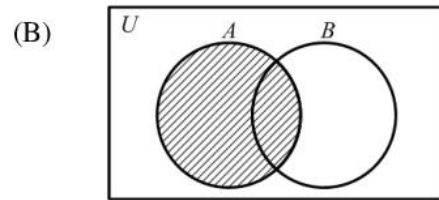
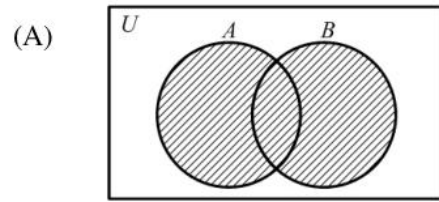

15. Tom bought a pen for \$60 and sold it to gain 20% on his cost price. How much money did he gain?

- (A) \$12
- (B) \$40
- (C) \$72
- (D) \$80

16. An article costs \$161. If a profit of 13% is to be made the selling price, in dollars, is

- (A)  $161 (1 + \frac{13}{100})$
- (B)  $13 (1 + \frac{161}{100})$
- (C)  $161 (13 + \frac{13}{100})$
- (D)  $13 (161 + \frac{13}{100})$

17. Mr. Duncan bought a table at a discount of 30% thus saving \$42. What was the marked price of the table?
- (A) \$ 98  
 (B) \$110  
 (C) \$140  
 (D) \$182
18. A television set costs \$350 cash. When bought on hire purchase, a deposit of \$35 is required, followed by 12 monthly payments of \$30. How much is saved by paying cash?
- (A) \$10  
 (B) \$25  
 (C) \$40  
 (D) \$45
19. A company employs 12 gardeners at \$26 per day, and 8 clerks at \$17 per day. What is the mean daily wage, in dollars, of the 20 employees?
- (A) \$20.00  
 (B) \$21.50  
 (C) \$22.40  
 (D) \$31.50
20. If \$7000 is borrowed at the rate of 5% per annum for 3 years, the simple interest is
- (A) \$ 105  
 (B) \$ 210  
 (C) \$ 370  
 (D) \$1 050
21. A man's taxable income is found to be \$15 200. He pays tax at the rate of 25%. The amount of income tax he pays is
- (A) \$3 775  
 (B) \$3 800  
 (C) \$3 825  
 (D) \$3 875

Item 22 refers to toothpaste which is sold in four different tubes.

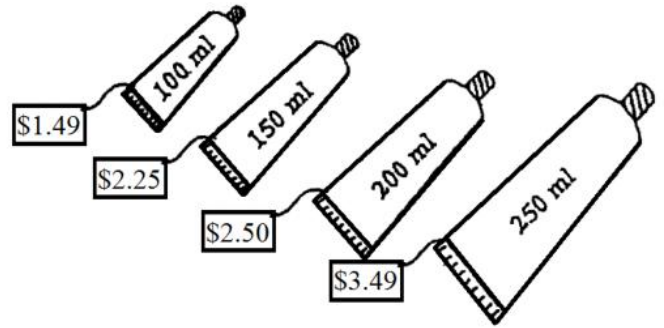

22. Which amount is the best buy?
- (A) 100 ml  
 (B) 150 ml  
 (C) 200 ml  
 (D) 250 ml
23.  $2x - 3(x + 8) =$
- (A)  $x + 8$   
 (B)  $-x - 24$   
 (C)  $5x + 8$   
 (D)  $-5x - 24$
24.  $5(x + y) - 3(x - y) =$
- (A)  $2x$   
 (B)  $2x + 2y$   
 (C)  $2x + 8y$   
 (D)  $8x + 8y$
25. For all  $a$  and  $b$ ,  $3a(a + 2b) - b(2a - 3b) \equiv$
- (A)  $3a^2 - ab + 3b^2$   
 (B)  $3a^2 + 4ab + 3b^2$   
 (C)  $3a^2 + 4ab - 3b^2$   
 (D)  $3a^2 + 8ab - 3b^2$

26. If  $a * b = \frac{b}{a} - 1$ , then  $7 * 28 =$

- (A)  $-\frac{3}{4}$   
 (B)  $\frac{1}{4}$   
 (C) 3  
 (D) 4

27. When simplified,  $\frac{4x}{7y} + \frac{3x}{5y}$  is written as

- (A)  $\frac{41x}{35y}$   
 (B)  $\frac{41x^2}{35y}$   
 (C)  $\frac{41xy}{35y}$   
 (D)  $\frac{20x+21y}{35y}$

28.  $3^x \times 3^y =$

- (A)  $9^{xy}$   
 (B)  $3^{xy}$   
 (C)  $9^{x+y}$   
 (D)  $3^{x+y}$

29. If  $20a - 16 = 12(3 - a)$ , then  $a =$

- (A)  $\frac{5}{8}$   
 (B)  $\frac{13}{8}$   
 (C)  $\frac{21}{16}$   
 (D)  $\frac{5}{2}$

30. If  $x$  is an integer which satisfies the inequalities  $4 < x - 2 < 8$ , then the smallest possible value of  $x$  is

- (A) 4  
 (B) 5  
 (C) 6  
 (D) 7

31. The sum of two numbers,  $x$  and  $y$ , is 18, and their difference is 14. Which pair of equations below describes the above statement?

- (A)  $2(x + y) = 18$   
 $2(x - y) = 4$   
 (B)  $2(xy) = 18$   
 $2(x - y) = 4$   
 (C)  $(x + y) = 18$   
 $(x - y) = 14$   
 (D)  $(x + y) = 22$   
 $(x - y) = 14$

32. The distance around the edge of a circular pond is 88 m. The radius, in metres is

- (A)  $88\pi$
- (B)  $176\pi$
- (C)  $\frac{88}{\pi}$
- (D)  $\frac{88}{2\pi}$

Item 33 refers to the circle below with centre O and circumference of 20 cm.

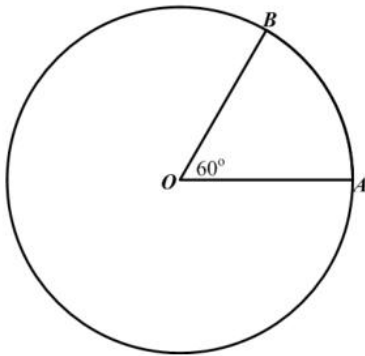

33. The length of the minor arc AB, in cm, is

- (A)  $\frac{1}{60} \times 20$
- (B)  $\frac{60}{360} \times 20$
- (C)  $\left(\frac{360-60}{360}\right) \times 20$
- (D)  $60 \times 20$

34. If the length of a rectangle is doubled, by what number must the width be multiplied in order that the area remains the same?

- (A) 3
- (B) 2
- (C)  $\frac{1}{2}$
- (D)  $\frac{1}{4}$

Item 35 refers to the trapezium below.

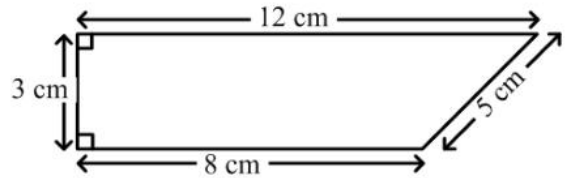

35. The area of the trapezium above is

- (A)  $24 \text{ cm}^2$
- (B)  $28 \text{ cm}^2$
- (C)  $30 \text{ cm}^2$
- (D)  $36 \text{ cm}^2$

36. The area of a rectangle is  $53.6 \text{ cm}^2$ . If the length is multiplied by four and the width is halved, the area would then be

- (A)  $214.4 \text{ cm}^2$
- (B)  $107.2 \text{ cm}^2$
- (C)  $53.6 \text{ cm}^2$
- (D)  $26.8 \text{ cm}^2$

Item 37 refers to the cube below

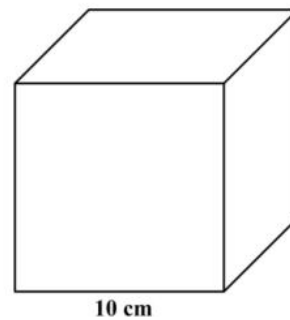

37. The volume of the cube is

- (A)  $1000 \text{ cm}^3$
- (B)  $300 \text{ cm}^3$
- (C)  $100 \text{ cm}^3$
- (D)  $30 \text{ cm}^3$

38. Item 38 refers to the cylinder below with radius 3cm and height 8 cm.

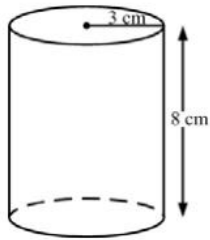

38. The volume of the cylinder is

- (A)  $12\pi \text{ cm}^3$
- (B)  $48\pi \text{ cm}^3$
- (C)  $72\pi \text{ cm}^3$
- (D)  $192\pi \text{ cm}^3$

39. If it took a speed boat 9 hours to travel a distance of 1080 km, what was its average speed?

- (A) 12 km/h
- (B) 102 km/h
- (C) 120 km/h
- (D) 1200 km/h

40. The pie-chart shows the preference in drinks of a group of students.

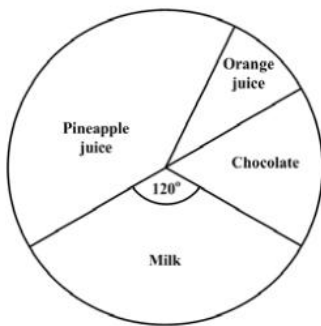

If 12 students prefer chocolate, then the total number of students in the group is

- (A) 48
- (B) 72
- (C) 180
- (D) 360

41. The median of the numbers: 1, 1, 5, 5, 6, 7, 7, 7, 7, 8 is

- (A) 7
- (B) 6.5
- (C) 6
- (D) 5.4

42. If the mean of four numbers 4, 8,  $x$  and 12 is 10, then  $x$  is

- (A) 4
- (B) 10
- (C) 12
- (D) 16

43. The highest weekly wage of a group of employees is \$105.40. If the range of the wages is \$27.50, how much does the lowest paid employee receive?

- (A) \$105.40
- (B) \$ 77.90
- (C) \$ 66.45
- (D) \$ 27.50

44. A bag contains 4 red balls and 5 blue balls. A ball is picked at random from the bag and is found to be red. It is not replaced. What is the probability that the next ball to be taken randomly from the bag will be blue?

- (A)  $\frac{1}{5}$
- (B)  $\frac{5}{9}$
- (C)  $\frac{3}{5}$
- (D)  $\frac{5}{8}$

Item 45 refers to the contents of the following table which shows the results of a survey of 100 households conducted by Form 5 students to determine the number of children in each household.

No. of children at home	0	1	2	3	4	5	6	7
Frequency	5	10	44	27	8	5	1	0

45. The probability that a home visited at random will contain exactly 4 children is

- (A)  $\frac{4}{100}$
- (B)  $\frac{8}{100}$
- (C)  $\frac{4}{28}$
- (D)  $\frac{4}{8}$

46. Which of the following mappings from set  $A$  to set  $B$  is a function?

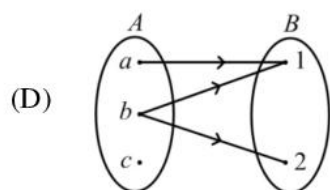
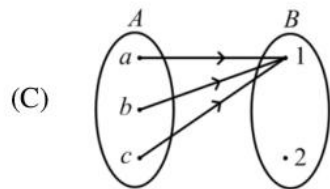
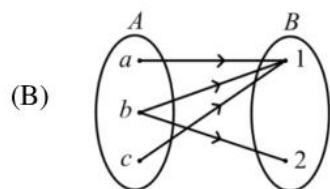
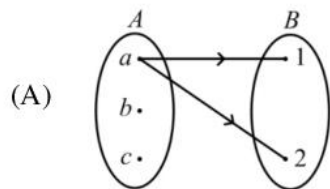

47. Which two graphs below represent functions?

I.

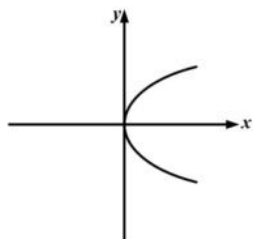

II.

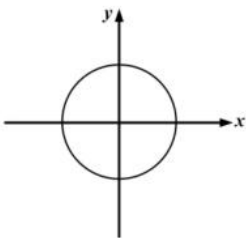

III.

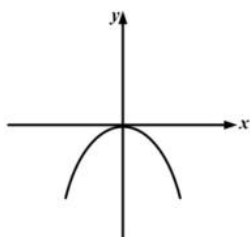

IV.

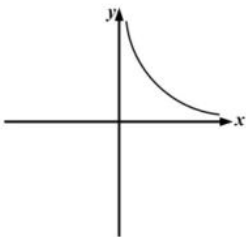

- (A) I and II
- (B) I and III
- (C) II and IV
- (D) III and IV

48. If  $h(x) = \frac{3x-2}{5}$ , then  $h(-6) =$

- (A) -4
- (B)  $-\frac{16}{5}$
- (C)  $\frac{16}{5}$
- (D) 4

Item 49 refers to the following graph.

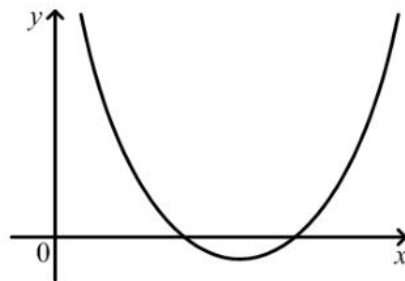

49. The diagram above shows a graph. If  $a$ ,  $b$  and  $c$  are positive constants, the equation of the graph could be

- (A)  $y = ax^2 + c$
- (B)  $y = c - ax^2$
- (C)  $y = ax^2 + bx + c$
- (D)  $y = c + bx - ax^2$

Item 50 refers to the following diagram

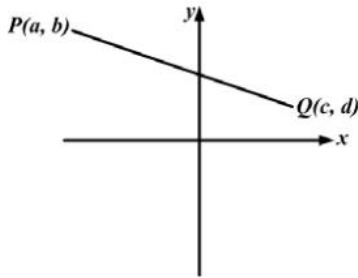

50. The diagram above shows a line  $PQ$ . The gradient of the line  $PQ$  is given by

- (A)  $\frac{b-d}{c-a}$
- (B)  $\frac{c-a}{b-d}$
- (C)  $\frac{a-c}{b-d}$
- (D)  $\frac{b-d}{a-c}$

Item 51 refers to the diagram below

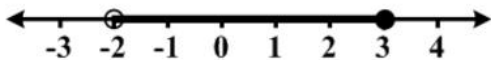

51. The graph of the inequality in the diagram above is defined by

- (A)  $-2 < x \leq 3$
- (B)  $-2 \leq x < 3$
- (C)  $-2 > x \geq 3$
- (D)  $-2 \geq x > 3$

Item 52 refers to the following diagram.

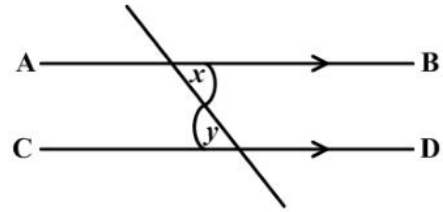

52. In the figure above,  $AB$  and  $CD$  are parallel. Which of the following BEST describes the relation between  $x$  and  $y$ ?

- (A)  $x + y < 2x$
- (B)  $x = y$
- (C)  $x + y > 2x$
- (D)  $x < y$

Item 53 refers to the following diagram.

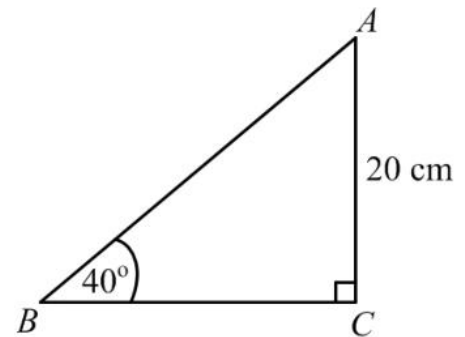

53. The triangle  $ABC$  above is right-angled at  $C$ .  $\angle ABC = 40^\circ$  and  $AC = 20$  cm. The length of  $BC$ , in cm, is

- (A)  $20 \sin 40^\circ$
- (B)  $\frac{20}{\sin 40^\circ}$
- (C)  $20 \tan 40^\circ$
- (D)  $\frac{20}{\tan 40^\circ}$

Item 54 – 55 refer to the following graph

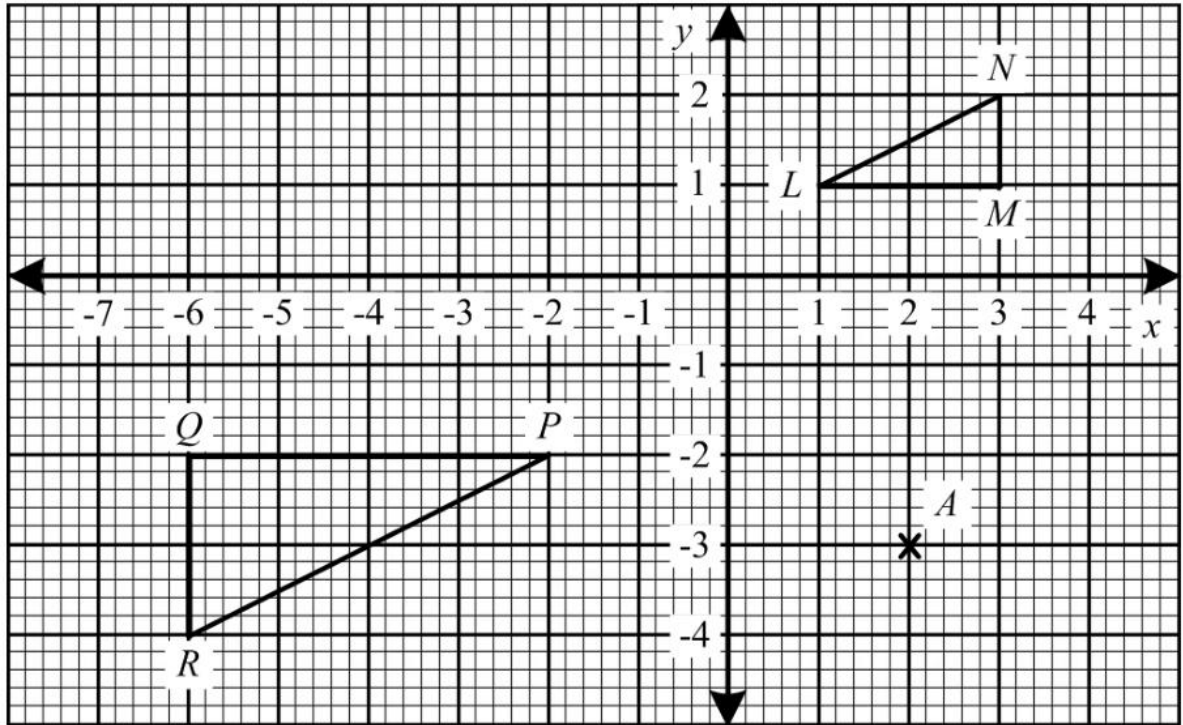

54. The point  $A(2,-3)$  is rotated about the origin through an angle of  $90^\circ$  in an anticlockwise direction. What are the coordinates of the image of  $A$ ?

- (A)  $(3,2)$
- (B)  $(2,3)$
- (C)  $(-3,-2)$
- (D)  $(-3,2)$

55. The transformation that maps  $\triangle LMN$  onto  $\triangle PQR$  is

- (A) a rotation through  $180^\circ$  about the origin
- (B) a rotation of  $180^\circ$  about  $\left(\frac{-1}{2}, \frac{-1}{2}\right)$
- (C) an enlargement about  $\left(\frac{1}{2}, \frac{-1}{2}\right)$  of scale factor 2
- (D) An enlargement about the origin of scale factor -2

Item 56 refers to the following graph which shows the point A.

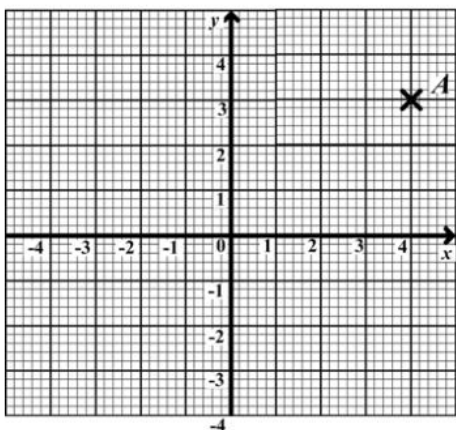

56. What are the co-ordinates of the image of A under reflection in the y-axis?

- (A) (-3, 4)
- (B) (3, -4)
- (C) (4, -3)
- (D) (-4, 3)

Item 57 refers to the following graph.

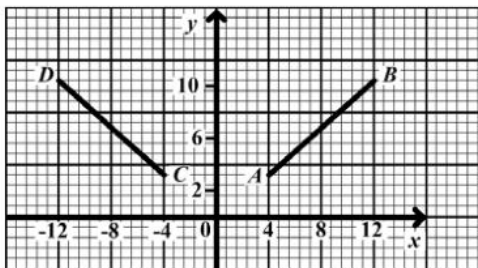

57. In the figure above, the line CD is the image of AB after

- (A) a rotation through  $90^\circ$  centre O
- (B) a reflection in the y-axis
- (C) a translation by vector  $\begin{pmatrix} -4 \\ -8 \end{pmatrix}$
- (D) an enlargement of scale factor -1

Item 58 refers to the following diagram.

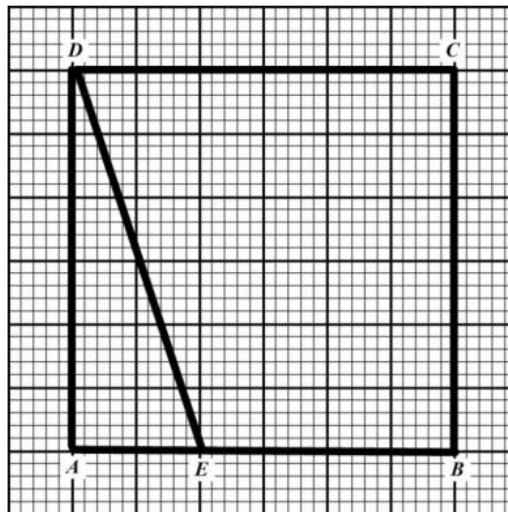

58. How many triangles congruent to  $\triangle ADE$  would be needed to cover the rectangle ABCD entirely?

- (A) 2
- (B) 4
- (C) 6
- (D) 8

Item 59 refers to the following diagram.

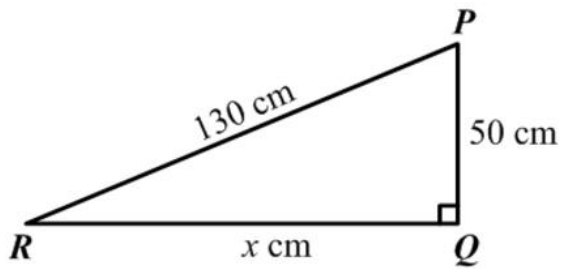

59. In the right-angled triangle above, **not drawn to scale**,  $\hat{Q} = 90^\circ$ ,  $PQ = 50$  cm,  $PR = 130$  cm and  $RQ = x$  cm.

$$\text{Tan } \hat{PRQ} =$$

- (A)  $\frac{50}{x}$
- (B)  $\frac{x}{50}$
- (C)  $\frac{50}{130}$
- (D)  $\frac{x}{130}$

Item 60 refers to the following diagram.

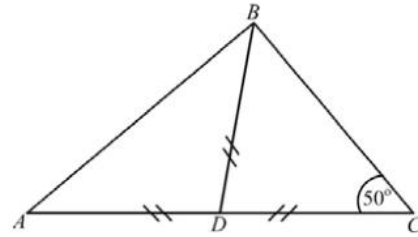

60. In the figure above,  $ABC$  is a triangle in which  $AD = BD = CD$ .

The angle  $ABC$  is

- (A)  $90^\circ$
- (B)  $80^\circ$
- (C)  $50^\circ$
- (D)  $40^\circ$

**IF YOU FINISH BEFORE TIME IS CALLED, CHECK YOUR WORK ON THIS TEST.**

↑ AFFIX SEAL HERE ↑

**CANDIDATE –PLEASE NOTE!**

You must sign below and return this booklet with the Answer Sheet. Failure to do so may result in disqualification.

\_\_\_\_\_  
SignatureTEST CODE **01234010**

MAY/JUNE 2006

**FORM TP 2007104**

**CARIBBEAN EXAMINATIONS COUNCIL**  
**SECONDARY EDUCATION CERTIFICATE**  
**EXAMINATION**  
**MATHEMATICS**  
**Paper 01 – General Proficiency**  
*90 minutes*

25 MAY 2006 (p.m.)

**READ THE FOLLOWING DIRECTIONS CAREFULLY**

1. In addition to this test booklet, you should have an answer sheet.
2. Calculators and mathematical tables may NOT be used for this paper.
3. **A list of formulae is provided on page 2 of this booklet.**
4. This test consists of 60 items. You will have 90 minutes to answer them.
5. Each item in this test has four suggested answers, lettered (A), (B), (C), (D). Read each item you are about to answer, and decide which choice is best.
6. On your answer sheet, find the number which corresponds to your item and blacken the space having the same letter as the answer you have chosen. Look at the sample item below.

Sample Item

$2a + 6a =$

- (A)  $8a$   
 (B)  $8a^2$   
 (C)  $12a$   
 (D)  $12a^2$

Sample Answer

The best answer to this item is “ $8a$ ”, so answer space (A) has been blackened.

7. If you want to change your answer, erase your old answer completely and fill in your new choice.
8. When you are told to begin, turn the page and work as quickly and as carefully as you can. If you cannot Answer an item, omit it and go on to the next one. You can return later to the item omitted. Your score will be the total number of correct answers.
9. You may do any rough work in the booklet.
10. Do not be concerned that the answer sheet provides spaces for more answers than there are items in this test.

**DO NOT TURN THIS PAGE UNTIL YOU ARE TOLD TO DO SO.**

Copyright © 2005 Caribbean Examinations Council ®.

**LIST OF FORMULAE**

Volume of a prism  $V = Ah$  where  $A$  is the area of a cross-section and  $h$  is the perpendicular length.

Volume of a cylinder  $V = \pi r^2 h$  where  $r$  is the radius of the base and  $h$  is the perpendicular height.

Volume of a right pyramid  $V = \frac{1}{3} Ah$  where  $A$  is the area of the base and  $h$  is the perpendicular height.

Circumference  $C = 2\pi r$  where  $r$  is the radius of the circle.

Area of a circle  $A = \pi r^2$  where  $r$  is the radius of the circle.

Area of Trapezium  $A = \frac{1}{2}(a + b)h$  where  $a$  and  $b$  are the lengths of the parallel sides and  $h$  is the perpendicular distance between the parallel sides.

Roots of quadratic equations If  $ax^2 + bx + c = 0$ ,  
 then  $x = \frac{-b \pm \sqrt{b^2 - 4ac}}{2a}$

Trigonometric ratios

$$\sin \theta = \frac{\text{opposite side}}{\text{hypotenuse}}$$

$$\cos \theta = \frac{\text{adjacent side}}{\text{hypotenuse}}$$

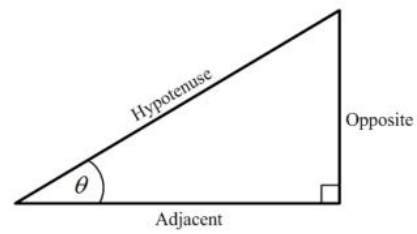
$$\tan \theta = \frac{\text{opposite side}}{\text{adjacent side}}$$

Area of triangle Area of  $\Delta = \frac{1}{2}bh$  where  $b$  is the length of the base and  $h$  is the perpendicular height

$$\text{Area of } \Delta ABC = \frac{1}{2} ab \sin C$$

$$\text{Area of } \Delta ABC = \sqrt{s(s-a)(s-b)(s-c)}$$

$$\text{where } s = \frac{a+b+c}{2}$$

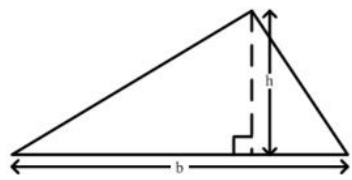

Sine rule  $\frac{a}{\sin A} = \frac{b}{\sin B} = \frac{c}{\sin C}$

Cosine rule  $a^2 = b^2 + c^2 - 2bc \cos A$

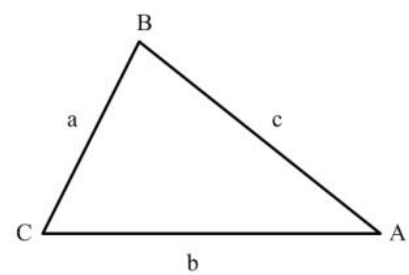

1.  $5\frac{2}{5} + 4\frac{3}{7} =$

- (A)  $9\frac{5}{35}$   
 (B)  $9\frac{6}{35}$   
 (C)  $9\frac{12}{35}$   
 (D)  $9\frac{29}{35}$

2. What percentage of 340 is 425?

- (A) 80%  
 (B) 85%  
 (C) 125%  
 (D) 152%

3. In scientific notation, 170.04 is written as

- (A)  $0.17004 \times 10^3$   
 (B)  $1.7004 \times 10^2$   
 (C)  $17.004 \times 10^1$   
 (D)  $1.7004 \times 10^{-1}$

Item 4 refers to the following diagram

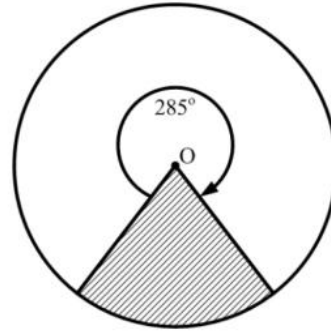

4. The fraction of the circle which has been shaded is

- (A)  $\frac{5}{24}$   
 (B)  $\frac{8}{24}$   
 (C)  $\frac{15}{24}$   
 (D)  $\frac{19}{24}$

5. There are 40 students in a class. Girls make up 60% of the class. 25% of the girls wear glasses. How many girls in the class wear glasses?

- (A) 6  
 (B) 8  
 (C) 10  
 (D) 15

6. If \$560 is shared in the ratio 2 : 3 : 9, the difference between the largest and the smallest shares is

- (A) \$ 80
- (B) \$240
- (C) \$280
- (D) \$360

7. The first three common multiples of 3, 4 and 6 are:

- (A) 0, 1, 2
- (B) 3, 4, 6
- (C) 6, 8, 12
- (D) 12, 24, 36

8. What is the HIGHEST common factor of the numbers {54, 72, 90}?

- (A) 9
- (B) 18
- (C) 90
- (D) 1080

9. 301 can be written as

- (A)  $3 \times 10^2 + 1$
- (B)  $3 \times 10^3 + 1$
- (C)  $3 \times 10^2 + 1 \times 10$
- (D)  $3 \times 10^3 + 1 \times 10$

10. By the distributive law,  $49 \times 17 + 49 \times 3 =$

- (A)  $49 + 20$
- (B)  $52 + 66$
- (C)  $49 \times 20$
- (D)  $52 \times 66$

Item 11 refers to the following Venn diagram.

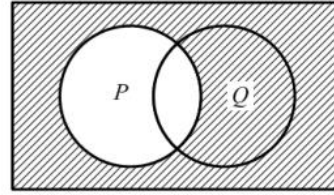

11. In the Venn diagram above, the shaded area represents

- (A)  $P'$
- (B)  $(P \cup Q)'$
- (C)  $Q \cup P'$
- (D)  $Q \cap P'$

12.  $P$  and  $Q$  are two finite sets such that  $n(P) = 7$ ,  $n(Q) = 5$  and  $n(P \cap Q) = 3$ . What is  $n(P \cup Q)$ ?

- (A) 6
- (B) 9
- (C) 15
- (D) 18

Item 13 refers to the following diagram.

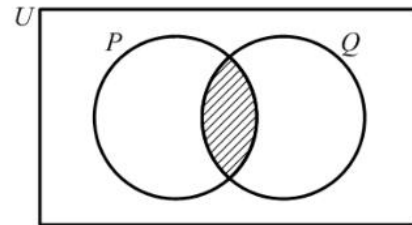

13. The two circles above represent set  $P$  and set  $Q$ . If  $P = \{\text{Factors of } 6\}$  and  $Q = \{\text{Factors of } 4\}$ , then the shaded region represents

- (A)  $\{ \}$
- (B)  $\{1, 2\}$
- (C)  $\{4, 6, 8, \dots\}$
- (D)  $\{12, 24, 36, \dots\}$

14.  $U = \{\text{Integers}\}$   
 $P = \{\text{Positive integers}\}$   
 $N = \{\text{Negative integers}\}$

Which of the Venn diagrams below illustrates the statement:

“No positive integers are negative integers” ?

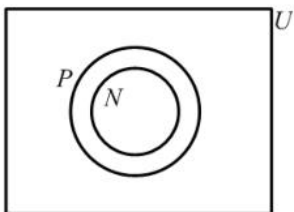
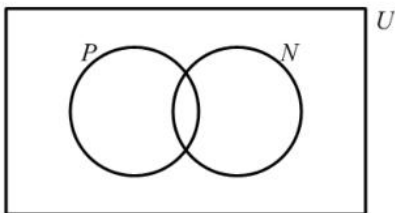
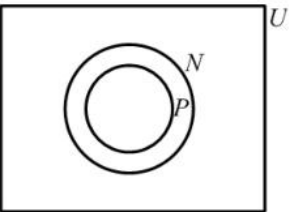
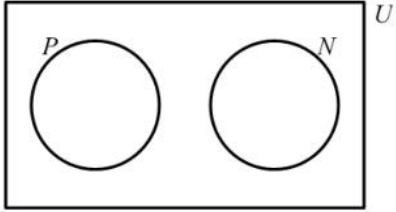
- (A) 
- (B) 
- (C) 
- (D) 

15. If  $p$  sweets are sold for  $q$  cents, then one sweet is sold for

- (A)  $\frac{p}{q}$  cents  
 (B)  $pq$  cents  
 (C)  $\frac{q}{p}$  cents  
 (D)  $(q - p)$  cents

16.  $3\frac{1}{4}\%$  of \$500 is

- (A) \$ 1.62  
 (B) \$15.52  
 (C) \$16.00  
 (D) \$16.25

17. Susan bought a calculator for \$120. She had to pay a sales tax of 10% on the price. How much change would she receive from \$140?

- (A) \$ 8.00  
 (B) \$12.00  
 (C) \$28.00  
 (D) \$32.00

18. \$600 invested at simple interest for 2 years earns \$96. What is the rate of interest per annum?

- (A)  $\frac{1}{8}\%$   
 (B)  $3\frac{1}{8}\%$   
 (C) 8%  
 (D)  $12\frac{1}{2}\%$

19. A plot of land is valued at \$18 000. Land tax is charged at the rate of \$0.70 per \$100 value. What is the TOTAL amount of tax paid for the land?

(A) \$110.00  
 (B) \$126.00  
 (C) \$180.70  
 (D) \$257.15

20. A customer buys a table on hire purchase. He makes a deposit of \$306 and pays six monthly instalments of \$60 each. The TOTAL cost to the customer is

(A) \$360  
 (B) \$366  
 (C) \$666  
 (D) \$966

21. Mary invested \$200 for 3 years at 5% per annum. John invested \$300 at the same rate. If they both received the same amount of money in simple interest, for how many years did John invest his money?

(A)  $1\frac{1}{2}$   
 (B) 2  
 (C) 3  
 (D) 10

22. A company employs 12 gardeners at \$26 per day, and 8 clerks at \$17 per day. What is the mean daily wage, in dollars, of the 20 employees?

(A) \$20.00  
 (B) \$21.50  
 (C) \$22.40  
 (D) \$31.50

23. If  $2(y-4) = 16$  then  $y =$

(A) 4  
 (B) 6  
 (C) 10  
 (D) 12

Item 24 refers to the expansion below.

$$(x+a)(x+b) = x^2 + (a+b)x + ab$$

24. The middle term in the expansion of  $(x+3)(x-1)$  is

(A) 2  
 (B) 3  
 (C)  $2x$   
 (D)  $4x$

25. The expression  $-2(x-4)$  is the same as

(A)  $-2x-8$   
 (B)  $-2x-4$   
 (C)  $-2x+4$   
 (D)  $-2x+8$

26. If  $m * n = \sqrt{mn - n^2}$ , then  $5 * 3 =$

(A)  $\sqrt{6}$   
 (B) 3  
 (C)  $\sqrt{15}$   
 (D) 6

27. If  $15^2 = 225$ , then the square root of 0.0225 is

- (A) 0.015
- (B) 0.15
- (C) 1.5
- (D) 15.0

28. Given,  $2x + 3 \geq 9$  the range of values of  $x$  is

- (A)  $x > 3$
- (B)  $x \geq 3$
- (C)  $x > 6$
- (D)  $x \geq 6$

29. When 6 is added to a number and the sum is divided by three, the result is four. This statement written in mathematical symbols is

- (A)  $\frac{6+x}{3} = 4$
- (B)  $\frac{6}{3} + x = 4$
- (C)  $\frac{6+x}{3} = \frac{4}{3}$
- (D)  $6 + \frac{x}{3} = 4$

30. John has  $x$  marbles and Max has twice as many. Max gives Tom 5 of his marbles. How many marbles does Max now have?

- (A)  $x + 5$
- (B)  $x - 5$
- (C)  $2x + 5$
- (D)  $2x - 5$

31. The sides of a triangle are  $x$  cm,  $(x-1)$  cm and  $(x+2)$  cm. IF the perimeter is 31 cm, then the SHORTEST side is

- (A) 9
- (B) 10
- (C) 11
- (D) 12

32. The mass, in kg, of a bag of rice is given as 10.6 kg **correct to 1 decimal place**. The range of values in which the actual mass lies is

- (A)  $10.5 < m < 10.7$
- (B)  $10.55 < m < 10.64$
- (C)  $10.59 < m < 10.69$
- (D)  $10.55 < m < 10.65$

33. The diagram below shows a cylinder with diameter 6 cm and height 20 cm.

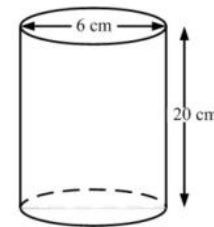

The volume, in  $\text{cm}^3$ , of the cylinder is

- (A)  $180\pi$
- (B)  $240\pi$
- (C)  $360\pi$
- (D)  $720\pi$

34. The distance around the edge of a circular pond is 88 m. The radius, in metres, is

- (A)  $176\pi$
- (B)  $88\pi$
- (C)  $\frac{88}{\pi}$
- (D)  $\frac{88}{2\pi}$

Item 35 refers to the following diagram

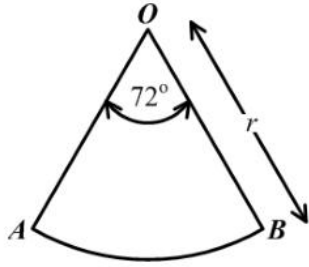

35.  $AOB$  is a sector of a circle such that angle  $AOB = 72^\circ$  and  $OB$  is  $r$  units long. The area of  $AOB$  is

- (A)  $\frac{1}{5}\pi r$
- (B)  $\frac{2}{5}\pi r$
- (C)  $\frac{1}{5}\pi r^2$
- (D)  $\frac{2}{5}\pi r^2$

Item 36 refers to the following diagram.

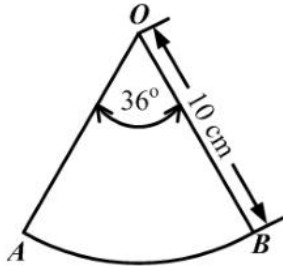

36. In the figure above,  $O$  is the centre of a circle of radius 10 cm and angle  $AOB$  is  $36^\circ$ . What is the length, in cm, of the arc  $AB$ ?

- (A)  $2\pi$
- (B)  $4\pi$
- (C)  $20\pi$
- (D)  $24\pi$

37. The circumference of a circle is 132 cm. Given that,  $\pi = \frac{22}{7}$  the radius of the circle is

- (A) 42
- (B) 21
- (C)  $\sqrt{42}$
- (D)  $\sqrt{21}$

38. Which of the figures below has an area equal to  $\frac{1}{2}(3+4)5$  square units?

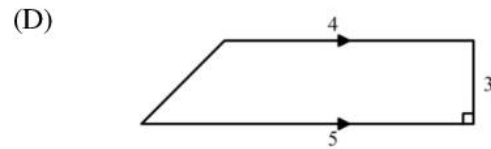
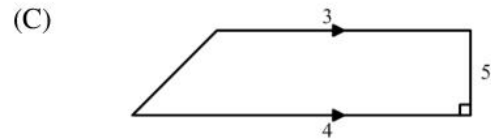
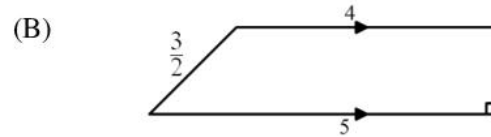
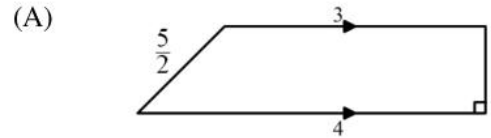

39. A man leaves home at 22:15 hrs and reaches his destination, in the same time zone, at 04:00 hrs on the following day. How many hours did the journey take?

- (A) 5
- (B)  $5\frac{3}{4}$
- (C) 6
- (D)  $6\frac{1}{4}$

40. The table below shows the frequency of scores obtained by students in a test.

Scores	2	3	5	6	8	10
Students	8	4	6	3	9	2

The range of scores is

- (A) 2
- (B) 7
- (C) 8
- (D) 10

Items 41-42 refer to the diagram below showing the number of persons who listen to Radio Stations A, B, C and D during the week.

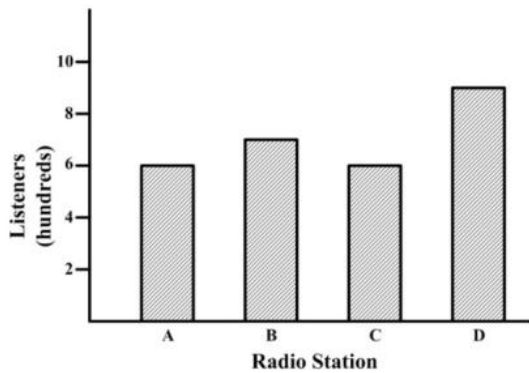

41. Which two stations **together** have more than 1500 listeners during the week?

- (A) A and B
- (B) A and D
- (C) C and D
- (D) B and D

42. Which station had as many listeners during the week as the mean number of listeners for the four stations during the week?

- (A) Station B
- (B) Station A
- (C) Station C
- (D) Station D

Item 43 refers to the scores below.

10    15    4    7  
8    8    1    4

43. The median of the eight scores presented above is

- (A) 4
- (B) 7.25
- (C) 7.50
- (D) 8

44. Here are 4 sets of numbers

- I. {1, 2, 6}
- II. {2, 4, 6}
- III. {1, 2, 5, 6, 7}
- IV. {10, 11, 12, 13, 14}

For which set(s) of numbers are the mean and median the same?

- (A) I only
- (B) II and IV only
- (C) I, II and III only
- (D) II, III, IV only

Item 45 refers to the diagram below

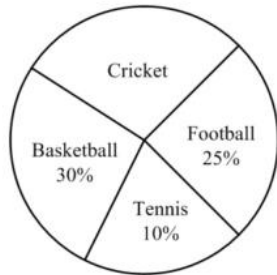

45. The pie chart shows the popular games played by 720 students. How many students play cricket?

- (A) 35
- (B) 120
- (C) 252
- (D) 300

46. Which of the following represents the equation of a straight line?

- (A)  $y = 2x + 3$
- (B)  $y = \frac{4}{x}$
- (C)  $y = x^2 - 4$
- (D)  $y = x^2 + 2x - 5$

Item 47 refers to the graph below

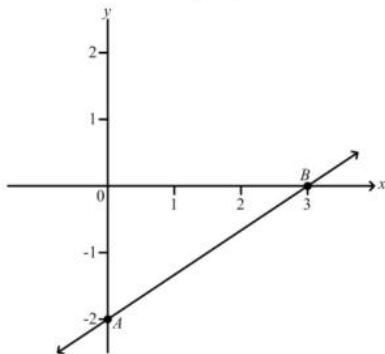

47. The straight line AB cuts the Y axis at

- (A) (0, 3)
- (B) (0, 2)
- (C) (3, -2)
- (D) (0, -2)

48. Which arrow diagram below shows the relation "is 3 less than"?

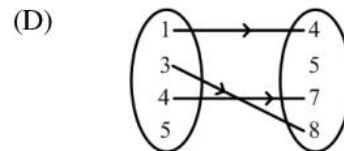
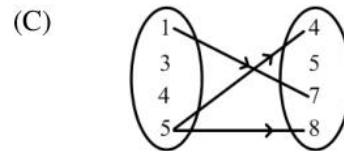
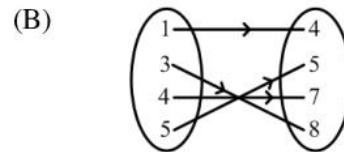
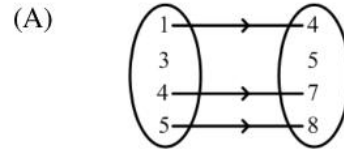

49. Which of the following points lies on the line  $y = 2x - 3$ ?

- (A) (2, 3)
- (B) (-2, -1)
- (C) (4, 1)
- (D) (0, -3)

Item 50 refers to the following diagram.

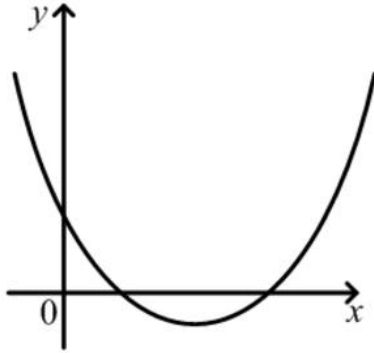

50. The diagram above shows a graph. If  $a$ ,  $b$  and  $c$  are constants and  $a > 0$ , the equation of the graph could be
- (A)  $y = ax^2 + c$
  - (B)  $y = c - ax^2$
  - (C)  $y = ax^2 + bx + c$
  - (D)  $y = c + bx - ax^2$

Item 51 below shows that the coordinate axes divide the  $xy$ -plane into 4 quadrants.

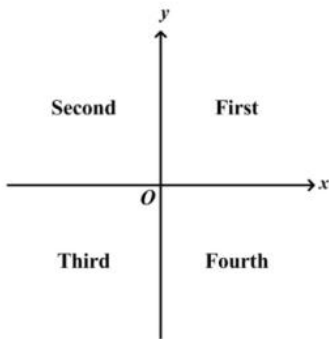

51. A point  $(x, y)$  lies in the fourth quadrant if
- (A)  $x > 0$  and  $y > 0$
  - (B)  $x < 0$  and  $y > 0$
  - (C)  $x < 0$  and  $y < 0$
  - (D)  $x > 0$  and  $y < 0$

Item 52 refers to the diagram below.

$AC$  and  $DE$  are straight lines intersecting at  $B$ .  
Angle  $DBA = 58^\circ$

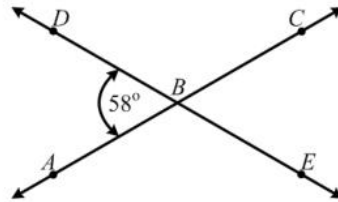

52. The measure of angle  $ABE$  is
- (A)  $58^\circ$
  - (B)  $122^\circ$
  - (C)  $142^\circ$
  - (D)  $302^\circ$

Item 53 refers to the cuboid below.

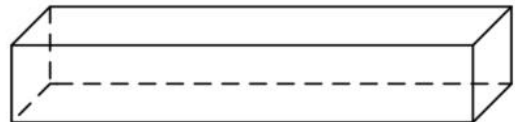

53. The number of faces, edges and vertices of the cuboid, written as an ordered triple of numbers, is
- (A) (6, 6, 6)
  - (B) (6, 8, 8)
  - (C) (6, 12, 8)
  - (D) (6, 12, 12)

54. A ship sailed 8 km due east from A to B. It then sailed 6 km due north to C. Which diagram below BEST represents the path of the ship?

(A)

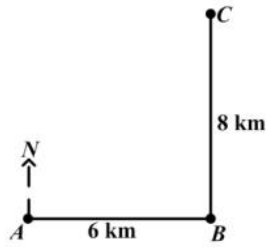

(B)

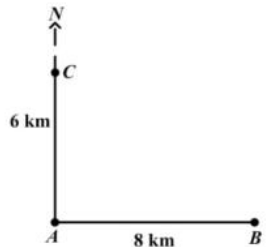

(C)

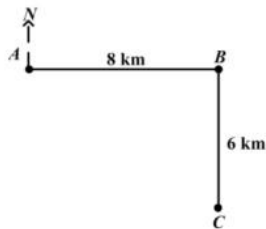

(D)

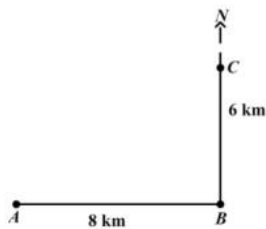

Item 55 refers to the diagram below.

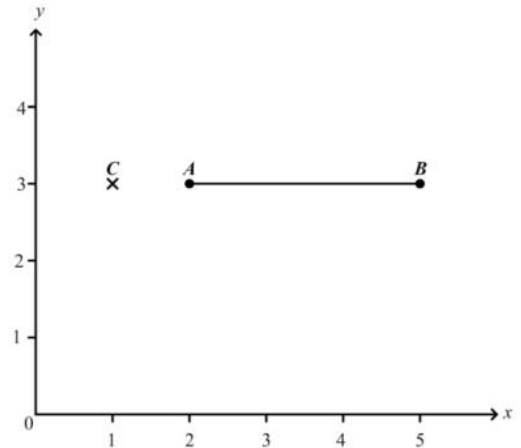

55. Line AB is rotated through  $90^\circ$  clockwise about the point C.

The coordinates of  $A'$ , the image of A are

- (A) (1, 1)
- (B) (1, 2)
- (C) (1, 4)
- (D) (2, 2)

Item 56 refers to the diagram below.

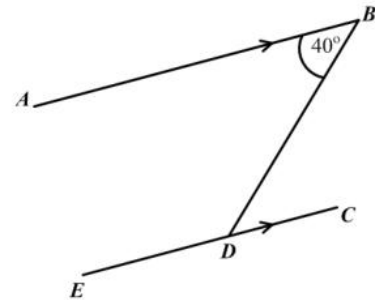

56.  $AB$  is parallel to  $EC$ . Calculate  $\angle BDE$

- (A)  $40^\circ$
- (B)  $50^\circ$
- (C)  $140^\circ$
- (D)  $180^\circ$

Item 57 refers to the diagram below.

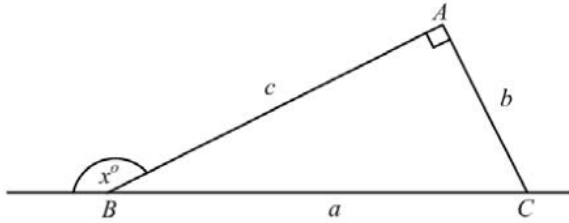

57. The value of  $\tan(180^\circ - x^\circ)$  is equal to

- (A)  $a/b$
- (B)  $b/c$
- (C)  $a/c$
- (D)  $b/a$

Item 58 refers to the diagram of a building below.

A boy stands 12 metres from the foot of the building and observes the angle of elevation of the top of the building.

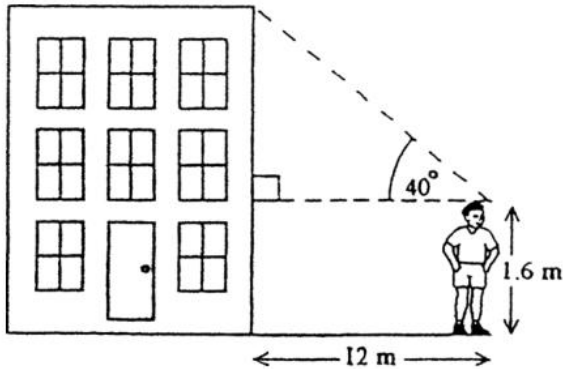

58. The height of the building is approximately

- (A)  $12 \tan 40^\circ$
- (B)  $1.6 + 12 \sin 40^\circ$
- (C)  $1.6 + 12 \cos 40^\circ$
- (D)  $1.6 + 12 \tan 40^\circ$

Item 59 refers to the following diagram.

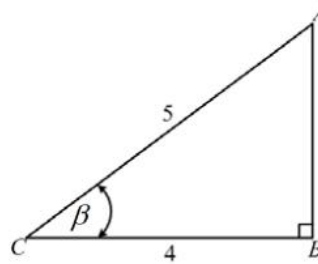

59. From the diagram above,  $\sin \beta$  is

- (A)  $\frac{3}{5}$
- (B)  $\frac{3}{4}$
- (C)  $\frac{4}{5}$
- (D)  $\frac{5}{3}$

Item 60 refers to the following diagram.

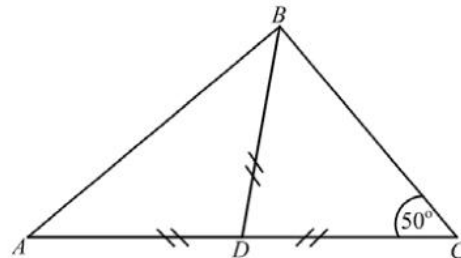

60. In the figure above,  $ABC$  is a triangle in which  $AD = BD = CD$ .

The angle  $ABC$  is

- (A)  $40^\circ$
- (B)  $50^\circ$
- (C)  $80^\circ$
- (D)  $90^\circ$

**IF YOU FINISH BEFORE TIME IS CALLED, CHECK YOUR WORK ON THIS TEST.**



↑ AFFIX SEAL HERE ↑

**CANDIDATE –PLEASE NOTE!**

You must sign below and return this booklet with the Answer Sheet. Failure to do so may result in disqualification.

\_\_\_\_\_  
SignatureTEST CODE **01234010**

JANUARY 2007

**FORM TP 2007104**

**CARIBBEAN EXAMINATIONS COUNCIL**  
**SECONDARY EDUCATION CERTIFICATE**  
**EXAMINATION**  
**MATHEMATICS**  
**Paper 01 – General Proficiency**  
*90 minutes*

03 JANUARY 2007 (p.m.)

**READ THE FOLLOWING DIRECTIONS CAREFULLY**

1. In addition to this test booklet, you should have an answer sheet.
2. Calculators and mathematical tables may NOT be used for this paper.
3. **A list of formulae is provided on page 2 of this booklet.**
4. This test consists of 60 items. You will have 90 minutes to answer them.
5. Each item in this test has four suggested answers, lettered (A), (B), (C), (D). Read each item you are about to answer, and decide which choice is best.
6. On your answer sheet, find the number which corresponds to your item and blacken the space having the same letter as the answer you have chosen. Look at the sample item below.

Sample Item

$2a + 6a =$

- (A)  $8a$   
 (B)  $8a^2$   
 (C)  $12a$   
 (D)  $12a^2$

Sample Answer

The best answer to this item is “ $8a$ ”, so answer space (A) has been blackened.

7. If you want to change your answer, erase your old answer completely and fill in your new choice.
8. When you are told to begin, turn the page and work as quickly and as carefully as you can. If you cannot Answer an item, omit it and go on to the next one. You can return later to the item omitted. Your score will be the total number of correct answers.
9. You may do any rough work in the booklet.
10. Do not be concerned that the answer sheet provides spaces for more answers than there are items in this test.

**DO NOT TURN THIS PAGE UNTIL YOU ARE TOLD TO DO SO.**

Copyright © 2005 Caribbean Examinations Council ®.

**LIST OF FORMULAE**

Volume of a prism  $V = Ah$  where  $A$  is the area of a cross-section and  $h$  is the perpendicular length.

Volume of a cylinder  $V = \pi r^2 h$  where  $r$  is the radius of the base and  $h$  is the perpendicular height.

Volume of a right pyramid  $V = \frac{1}{3} Ah$  where  $A$  is the area of the base and  $h$  is the perpendicular height.

Circumference  $C = 2\pi r$  where  $r$  is the radius of the circle.

Area of a circle  $A = \pi r^2$  where  $r$  is the radius of the circle.

Area of Trapezium  $A = \frac{1}{2}(a+b)h$  where  $a$  and  $b$  are the lengths of the parallel sides and  $h$  is the perpendicular distance between the parallel sides.

Roots of quadratic equations If  $ax^2 + bx + c = 0$ ,  
 then  $x = \frac{-b \pm \sqrt{b^2 - 4ac}}{2a}$

Trigonometric ratios

$$\sin \theta = \frac{\text{opposite side}}{\text{hypotenuse}}$$

$$\cos \theta = \frac{\text{adjacent side}}{\text{hypotenuse}}$$

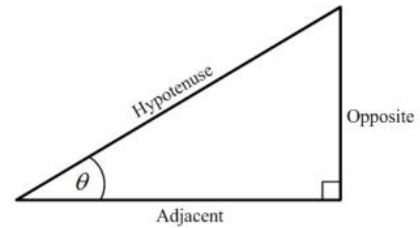
$$\tan \theta = \frac{\text{opposite side}}{\text{adjacent side}}$$

Area of triangle  $\text{Area of } \Delta = \frac{1}{2}bh$  where  $b$  is the length of the base and  $h$  is the perpendicular height

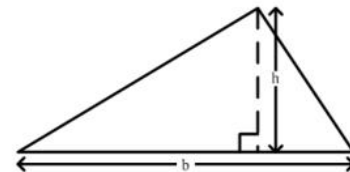

$$\text{Area of } \Delta ABC = \frac{1}{2} ab \sin C$$

$$\text{Area of } \Delta ABC = \sqrt{s(s-a)(s-b)(s-c)}$$

$$\text{where } s = \frac{a+b+c}{2}$$

Sine rule  $\frac{a}{\sin A} = \frac{b}{\sin B} = \frac{c}{\sin C}$

Cosine rule  $a^2 = b^2 + c^2 - 2bc \cos A$

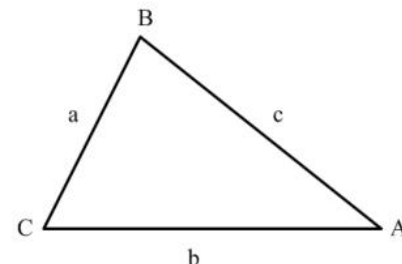

1. The exact value of  $6 \div (0.0003)$  is
- (A) 200  
(B) 2000  
(C) 20000  
(D) 200000
2. 0.0346 written in standard form is
- (A)  $3.46 \times 10^2$   
(B)  $3.46 \times 10$   
(C)  $3.46 \times 10^{-1}$   
(D)  $3.46 \times 10^{-2}$
3. Express 0.12 as a fraction in its lowest terms
- (A)  $\frac{1}{9}$   
(B)  $\frac{3}{5}$   
(C)  $\frac{1}{8}$   
(D)  $\frac{3}{25}$
4.  $\sqrt{17^2 - 15^2}$
- (A) 1  
(B) 2  
(C) 8  
(D) 16
5. John, Peter and Mary shared a sum of money in the ratio 2:4:9. John and Peter together received \$360. How much money in all was shared?
- (A) \$480  
(B) \$540  
(C) \$600  
(D) \$900
6. Express  $4\frac{3}{8}$  as a decimal correct to 3 significant figures
- (A) 4.30  
(B) 4.37  
(C) 4.38  
(D) 4.40
7. What is the HIGHEST common factor of the set of numbers {54, 72, 90}?
- (A) 9  
(B) 18  
(C) 90  
(D) 1080
8.  $(-\frac{1}{2})^3$  is the same as
- (A)  $-\frac{1}{8}$   
(B)  $-\frac{1}{6}$   
(C)  $\frac{1}{8}$   
(D)  $\frac{1}{6}$
9. What is the value of the digit 2 in the number 48.621?
- (A)  $\frac{2}{100}$   
(B)  $\frac{2}{10}$   
(C) 2  
(D) 200

10. By the distributive law  $49 \times 17 + 49 \times 3 =$

- (A)  $52 + 66$
- (B)  $52 \times 66$
- (C)  $49 + 20$
- (D)  $49 \times 20$

Item 11 refers to the Venn diagram below.

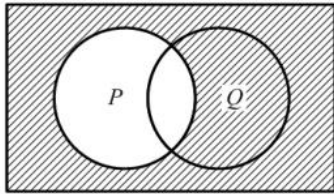

11. In the Venn diagram above, the shaded area represents

- (A)  $P'$
- (B)  $(P \cup Q)'$
- (C)  $P' \cup Q$
- (D)  $P' \cap Q$

Item 12 refers to the Venn diagram below.

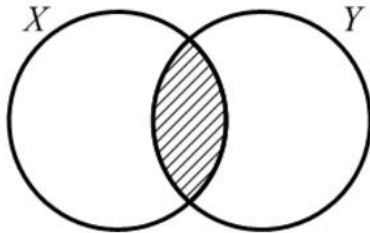

12. In the figure above, X represents the set of multiples of four. Y represents the set of multiples of five. The shaded region represents the set of all multiples of

- (A) 8
- (B) 9
- (C) 10
- (D) 20

13. In which one of the following Venn diagrams is the region  $A \cap B'$  shaded?

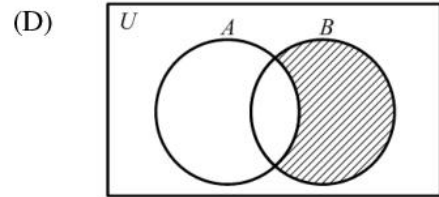
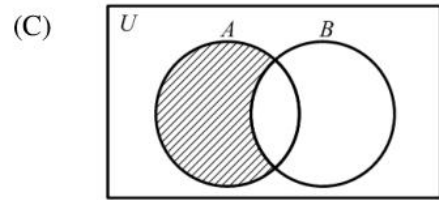
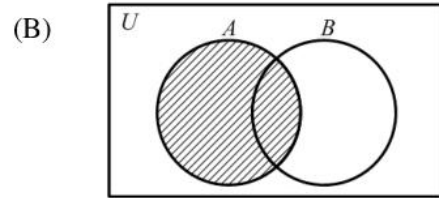
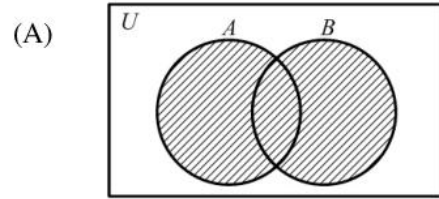

14.  $A = \{\text{Factors of } 30\}$   
 $B = \{\text{Prime numbers less than } 10\}$   
 $C = \{\text{Even whole numbers less than } 10\}$

Then  $n(A \cap B \cap C)$  is

- (A) 0
- (B) 1
- (C) 2
- (D) 9

15. If  $p$  sweets cost  $q$  cents, then the cost of one sweet is

- (A)  $\frac{p}{q}$  cents
- (B)  $pq$  cents
- (C)  $\frac{q}{p}$  cents
- (D)  $(q - p)$  cents

16. A dress which costs \$180 is being sold at a discount of 10%. The amount of the discount is

- (A) \$ 1.80
- (B) \$ 10.00
- (C) \$ 18.00
- (D) \$170.00

17. An article bought for \$125 was sold for \$175. The percentage profit was

- (A) 28.6
- (B) 40
- (C) 50
- (D) 71.4

Item 18 refers to the table below.

Mark	0	1	2	3	4	5	6	7	8	9
No. of students	5	2	3	4	6	8	8	4	9	1

18. The table above shows the marks obtained by 50 students in a test. What is the probability that a student chosen at random would have obtained a score less than 5?

- (A)  $\frac{2}{5}$
- (B)  $\frac{3}{5}$
- (C)  $\frac{11}{25}$
- (D)  $\frac{14}{25}$

Item 19 refers to the table below.

House Insurance	25¢ per \$100
Contents Insurance	50¢ per \$100

19. The above table shows the rates charged by an insurance company. How much will a person pay for his insurance, if his house is valued at \$50 000, and the contents at \$10 000?

- (A) \$500
- (B) \$450
- (C) \$225
- (D) \$175

20. Tom bought a pen for \$60 and sold it to gain 20% on his cost price. How much money did he gain?

(A) \$12  
 (B) \$40  
 (C) \$72  
 (D) \$80

21. Mary invested \$200 for 3 years at 5% per annum. John invested \$300 at the same rate. If they both received the same amount of money in interest, for how many years did John invest his money?

(A)  $1\frac{1}{2}$   
 (B) 2  
 (C) 3  
 (D) 10

22. A woman buys a pair of shoes at a sale. She pays \$60, saving \$15 on the regular price. The percentage discount on the shoes is

(A) 20  
 (B) 25  
 (C)  $33\frac{1}{3}$   
 (D) 80

23.  $-2(x-4)$

(A)  $-2x-8$   
 (B)  $-2x-4$   
 (C)  $-2x+4$   
 (D)  $-2x+8$

Item 24 refers to the information below

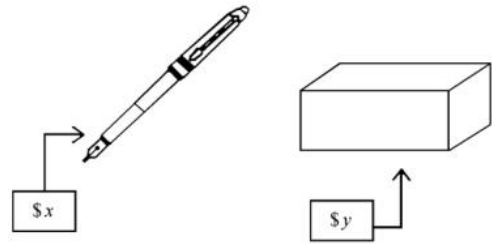

24. The total cost of 3 pens and 2 boxes is

(A)  $6xy$   
 (B)  $5(x+y)$   
 (C)  $3x+2y$   
 (D)  $2x+3y$

25.  $3a(a+2b)-b(2a-3b) =$

(A)  $3a^2-ab+3b^2$   
 (B)  $3a^2+4ab+3b^2$   
 (C)  $3a^2+4ab-3b^2$   
 (D)  $3a^2+8ab-3b^2$

26. Given that  $a * b = 2a - 3b$ , then  $2 * (-3) =$

(A) 13  
 (B) 3  
 (C) -5  
 (D) -7

27.  $2(a^2b)^3 =$

(A)  $2a^5b^3$   
 (B)  $2a^6b^3$   
 (C)  $6a^2b$   
 (D)  $8a^6b^3$

28. Given that  $2x+3 \geq 9$ , the range of values of  $x$  is

(A)  $x > 3$   
 (B)  $x \geq 3$   
 (C)  $x > 6$   
 (D)  $x \geq 6$

29. Given that  $3(x-1) - 2(x-1) = 7$ , the value of  $x$  is
- (A) 6  
(B) 7  
(C) 8  
(D) 9

30. John has  $x$  marbles and Max has twice as many. Max gives John 5 of his marbles. How many marbles does Max now have?

- (A)  $x + 5$   
(B)  $x - 5$   
(C)  $2x + 5$   
(D)  $2x - 5$

Item 31 refers to the following diagram.

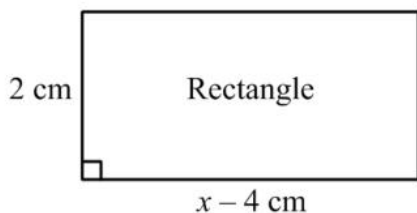

31. The area of the rectangle, in  $\text{cm}^2$ , is  $x^2$ . The equation that may be used to find the value of  $x$  is

- (A)  $x^2 = 2(x-4)$   
(B)  $x^2 = (x-2)(x-4)$   
(C)  $x^2 = 2(x-4)(x-2)$   
(D)  $x^2 = (x-4)(x+2)$

32. The mass, in kg, of a bag of rice is given as 10.6 **correct to 1 decimal place**. The range of values in which the actual mass lies is

- (A)  $10.5 \leq m \leq 10.7$   
(B)  $10.55 \leq m < 10.65$   
(C)  $10.59 \leq m \leq 10.69$   
(D)  $10.55 \leq m \leq 10.65$

33. The volume of a cube whose edge is 6 cm long is

- (A)  $18 \text{ cm}^3$   
(B)  $36 \text{ cm}^3$   
(C)  $72 \text{ cm}^3$   
(D)  $216 \text{ cm}^3$

Item 34 refers to the figure below.

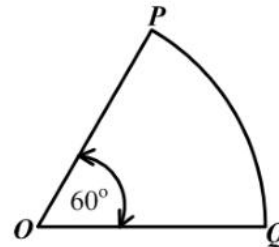

34. The figure above, not drawn to scale, shows a sector of a circle centre  $O$ . The length of the minor arc  $PQ$  is 8 cm. What is the length of the circumference of the entire circle?

- (A) 16 cm  
(B) 24 cm  
(C) 48 cm  
(D) 64 cm

35. The distance around the edge of a circular pond is 88 m. The radius, in metres is

- (A)  $88\pi$   
(B)  $176\pi$   
(C)  $\frac{88}{\pi}$   
(D)  $\frac{88}{2\pi}$

Item 36 refers to the diagrams below.

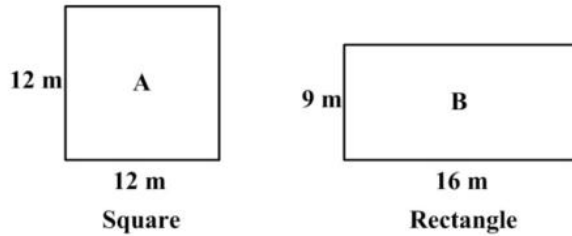

36. Which of the following statements is true about the perimeters of the figures A and B?

- (A) Perimeter of A = Perimeter of B
- (B) Perimeter of A > Perimeter of B
- (C) Perimeter of A  $\geq$  Perimeter of B
- (D) Perimeter of A < Perimeter of B

37. The lengths of the sides of a triangle are  $x$ ,  $2x$  and  $2x$  centimetres. If the perimeter is 20 centimetres, what is the value of  $x$ ?

- (A) 4
- (B) 5
- (C) 8
- (D) 10

38. The area of a rectangle is  $53.6 \text{ cm}^2$ . If the length is multiplied by four and the width is halved, the area would then be

- (A)  $26.8 \text{ cm}^2$
- (B)  $53.6 \text{ cm}^2$
- (C)  $107.2 \text{ cm}^2$
- (D)  $214.4 \text{ cm}^2$

39. Each exterior angle of a regular polygon measures  $45^\circ$ . How many sides has the polygon?

- (A) 10
- (B) 8
- (C) 6
- (D) 4

Items 40-42 refer to the diagram below which shows the sport chosen by 160 boys who participated in a games evening at their school

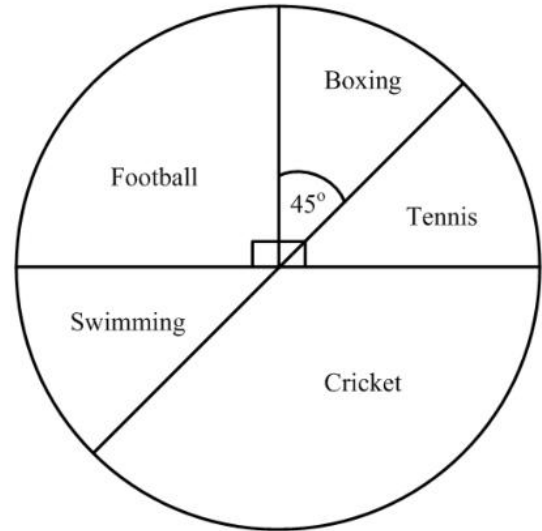

40. The number of boys who chose football is

- (A) 40
- (B) 90
- (C) 110
- (D) 150

41. The probability that a boy chosen at random participated in boxing is

- (A)  $\frac{1}{8}$
- (B)  $\frac{1}{4}$
- (C)  $\frac{1}{2}$
- (D)  $\frac{7}{8}$

42. How many boys participated in cricket?

- (A) 54
- (B) 60
- (C) 110
- (D) 120

43. Which of the following is NOT a statistical diagram?

- (A) Bar graph
- (B) Pie chart
- (C) Frequency polygon
- (D) Modal class

44. A bag contains 2 red , 4 yellow and 6 blue balls. The probability of drawing a **blue** ball from the bag at random is

- (A)  $\frac{1}{6}$
- (B)  $\frac{1}{3}$
- (C)  $\frac{1}{2}$
- (D)  $\frac{6}{11}$

Item 45 refers to the table below which shows the frequency of scores obtained by students in a test.

Scores	2	3	5	6	8	11
Students	8	4	6	3	12	2

45. The modal score is

- (A) 8
- (B) 9
- (C) 10
- (D) 12

Item 46 refers to the arrow diagram below.

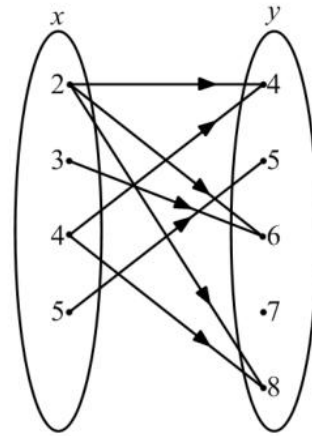

46. The arrow diagram above describes the relation

- (A)  $x$  is greater than  $y$
- (B)  $x$  is a multiple of  $y$
- (C)  $x$  is divisible by  $y$
- (D)  $x$  is a factor of  $y$

Item 47 refers to the figure below.

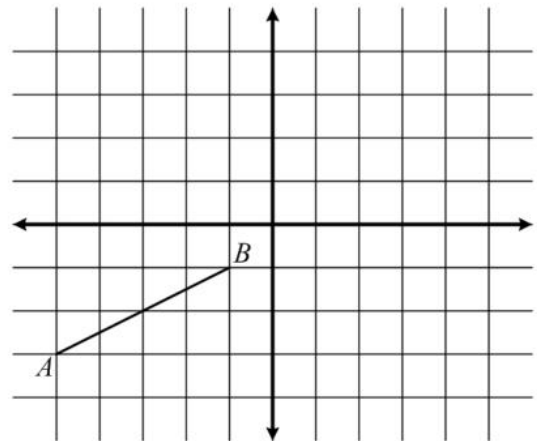

47. The gradient of  $AB$  in the figure above is

- (A) 2
- (B)  $\frac{1}{2}$
- (C)  $-\frac{1}{2}$
- (D) -2

48. The arrow diagram below shows a function.

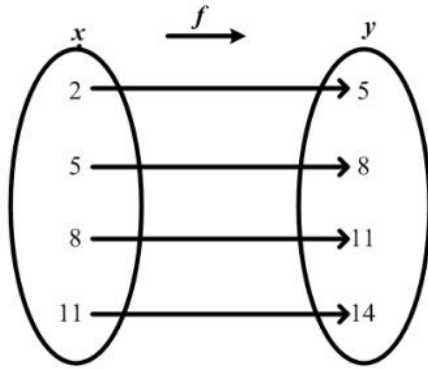

Which of the following BEST describes the function?

- (A)  $f(x) = x + 3$
- (B)  $f(x) = y + 3$
- (C)  $x = y + 3$
- (D)  $y = x$

49. The range of  $f : x \rightarrow x^3$  for the domain  $\{-2, -1, 0, 1, 2\}$  is

- (A)  $\{0, 1, 8\}$
- (B)  $\{-2, -1, 0, 1, 2\}$
- (C)  $\{-6, -3, 0, 3, 6\}$
- (D)  $\{-8, -1, 0, 1, 8\}$

Item 50 refers to the following graph.

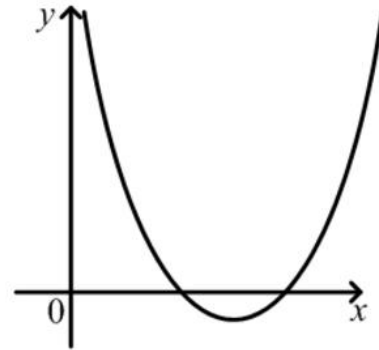

50. If  $a$ ,  $b$  and  $c$  are constants, the equation of the graph could be

- (A)  $y = ax^2 + c$
- (B)  $y = c - ax^2$
- (C)  $y = ax^2 + bx + c$
- (D)  $y = c + bx - ax^2$

51. Which of the following represents the graph of a function?

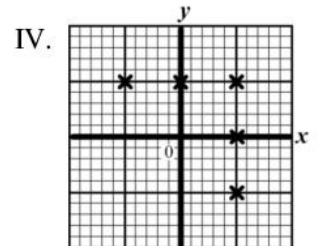
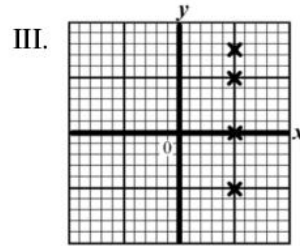
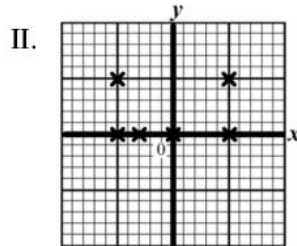
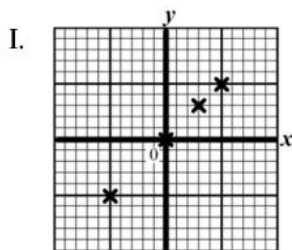

- (A) I
- (B) II
- (C) III
- (D) IV

Item 52 refers to the diagram below of a construction. With centre  $A$ , an arc  $BC$  is drawn. With centre  $B$ , and the same radius, the arc  $PCQ$  is drawn.

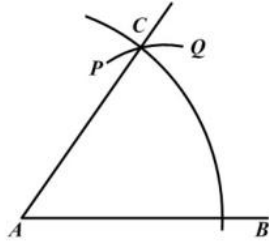

52. What is the measure of  $\angle BAC$  ?

- (A)  $30^\circ$
- (B)  $45^\circ$
- (C)  $60^\circ$
- (D)  $75^\circ$

Item 53 refers to the right-angled triangle below.

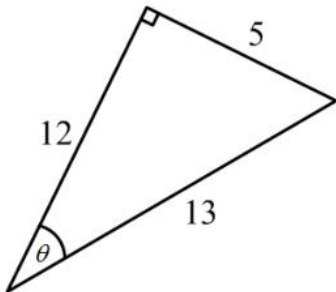

53. In the right-angled triangle above,  $\tan \theta$  is

- (A)  $\frac{5}{13}$
- (B)  $\frac{5}{12}$
- (C)  $\frac{12}{5}$
- (D)  $\frac{13}{5}$

54. A ship sailed 8 km due east from  $A$  to  $B$ . It then sailed 6 km due north to  $C$ . Which diagram below BEST represents the path of the ship?

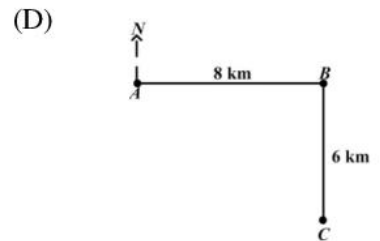
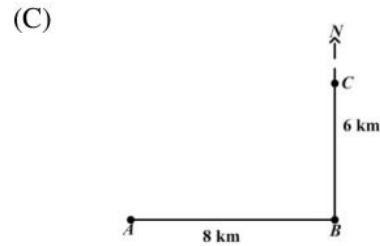
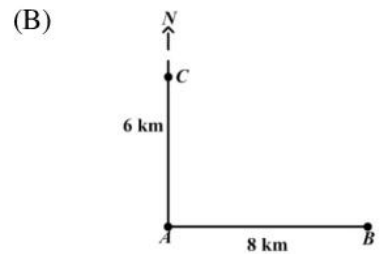
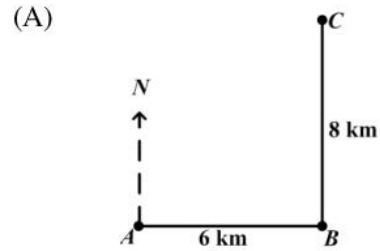

55. The image of a point  $P(-2, 3)$  under a translation

$$\begin{pmatrix} 3 \\ 4 \end{pmatrix}$$
 is

- (A)  $(-6, 12)$
- (B)  $(-5, -1)$
- (C)  $(5, 1)$
- (D)  $(1, 7)$

Item 56 refers to the diagram below.

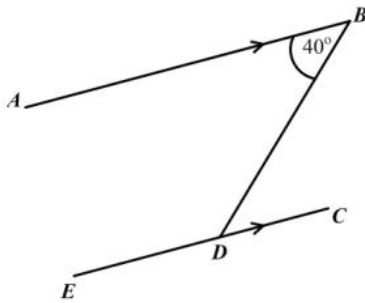

56. In the diagram above,  $AB$  is parallel to  $EC$ . Calculate  $\angle BDE$

- (A)  $40^\circ$
- (B)  $50^\circ$
- (C)  $140^\circ$
- (D)  $180^\circ$

59. A plane is heading in a direction of  $045^\circ$  and changes course in a clockwise direction to  $135^\circ$ . The angle through which the plane turns is

- (A)  $45^\circ$
- (B)  $90^\circ$
- (C)  $135^\circ$
- (D)  $270^\circ$

Item 57 refers to the diagram below.

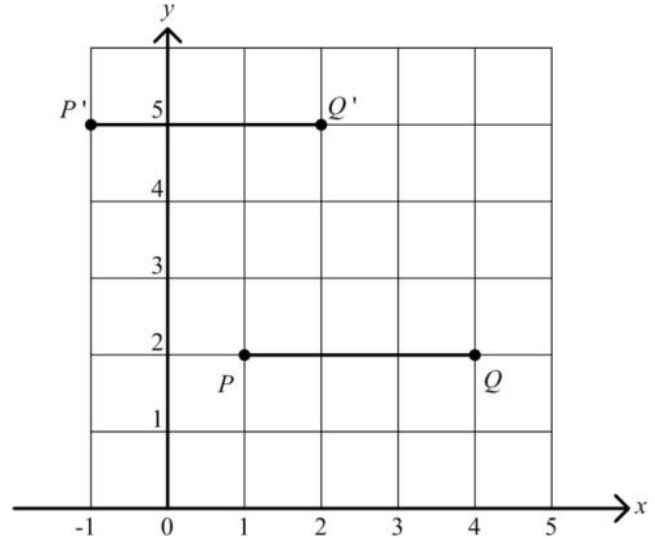

57. In the diagram above, the vector that translates  $PQ$  to  $P'Q'$  may be described as

- (A)  $\begin{pmatrix} 2 \\ 3 \end{pmatrix}$
- (B)  $\begin{pmatrix} 2 \\ -3 \end{pmatrix}$
- (C)  $\begin{pmatrix} -2 \\ 3 \end{pmatrix}$
- (D)  $\begin{pmatrix} -2 \\ -3 \end{pmatrix}$

Item 58 refers to the diagram below.

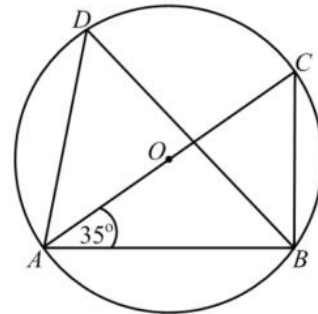

58. In the diagram above,  $\angle CAB = 35^\circ$  and  $AC$  is the diameter of the circle. Angle  $ADB$  is

- (A)  $55^\circ$
- (B)  $45^\circ$
- (C)  $35^\circ$
- (D)  $65^\circ$

60. In each of the diagrams shown below,  $A'$  is the image of  $A$ . Which of the diagrams shows a reflection in the  $x$  axis?

(A)

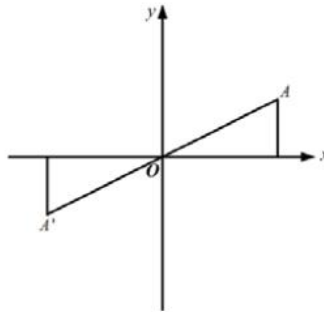

(B)

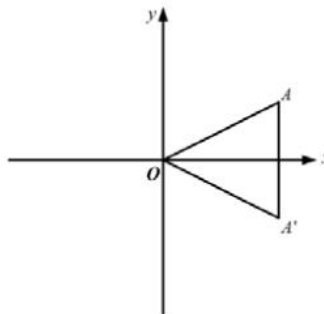

(C)

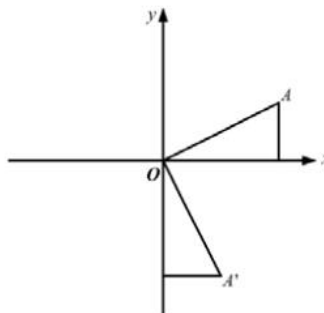

(D)

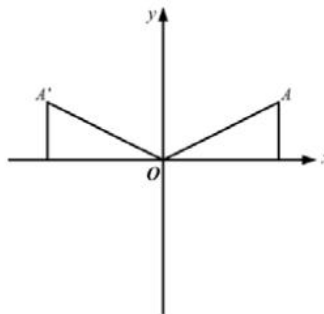

**IF YOU FINISH BEFORE TIME IS CALLED, CHECK YOUR WORK ON THIS TEST.**



↑ AFFIX SEAL HERE ↑

**CANDIDATE –PLEASE NOTE!**

You must sign below and return this booklet with the Answer Sheet. Failure to do so may result in disqualification.

\_\_\_\_\_  
SignatureTEST CODE **01234010**

MAY/JUNE 2007

**FORM TP 2007104**

**CARIBBEAN EXAMINATIONS COUNCIL**  
**SECONDARY EDUCATION CERTIFICATE**  
**EXAMINATION**  
**MATHEMATICS**  
**Paper 01 – General Proficiency**  
*90 minutes*

24 MAY 2007 (p.m.)

**READ THE FOLLOWING DIRECTIONS CAREFULLY**

1. In addition to this test booklet, you should have an answer sheet.
2. Calculators and mathematical tables may NOT be used for this paper.
3. **A list of formulae is provided on page 2 of this booklet.**
4. This test consists of 60 items. You will have 90 minutes to answer them.
5. Each item in this test has four suggested answers, lettered (A), (B), (C), (D). Read each item you are about to answer, and decide which choice is best.
6. On your answer sheet, find the number which corresponds to your item and blacken the space having the same letter as the answer you have chosen. Look at the sample item below.

Sample Item

$2a + 6a =$

- (A)  $8a$   
 (B)  $8a^2$   
 (C)  $12a$   
 (D)  $12a^2$

Sample Answer

The best answer to this item is “ $8a$ ”, so answer space (A) has been blackened.

7. If you want to change your answer, erase your old answer completely and fill in your new choice.
8. When you are told to begin, turn the page and work as quickly and as carefully as you can. If you cannot Answer an item, omit it and go on to the next one. You can return later to the item omitted. Your score will be the total number of correct answers.
9. You may do any rough work in the booklet.
10. Do not be concerned that the answer sheet provides spaces for more answers than there are items in this test.

**DO NOT TURN THIS PAGE UNTIL YOU ARE TOLD TO DO SO.**

Copyright © 2006 Caribbean Examinations Council ®.

**LIST OF FORMULAE**

Volume of a prism  $V = Ah$  where  $A$  is the area of a cross-section and  $h$  is the perpendicular length.

Volume of a cylinder  $V = \pi r^2 h$  where  $r$  is the radius of the base and  $h$  is the perpendicular height.

Volume of a right pyramid  $V = \frac{1}{3} Ah$  where  $A$  is the area of the base and  $h$  is the perpendicular height.

Circumference  $C = 2\pi r$  where  $r$  is the radius of the circle.

Area of a circle  $A = \pi r^2$  where  $r$  is the radius of the circle.

Area of Trapezium  $A = \frac{1}{2}(a+b)h$  where  $a$  and  $b$  are the lengths of the parallel sides and  $h$  is the perpendicular distance between the parallel sides.

Roots of quadratic equations If  $ax^2 + bx + c = 0$ ,

$$\text{then } x = \frac{-b \pm \sqrt{b^2 - 4ac}}{2a}$$

Trigonometric ratios

$$\sin \theta = \frac{\text{opposite side}}{\text{hypotenuse}}$$

$$\cos \theta = \frac{\text{adjacent side}}{\text{hypotenuse}}$$

$$\tan \theta = \frac{\text{opposite side}}{\text{adjacent side}}$$

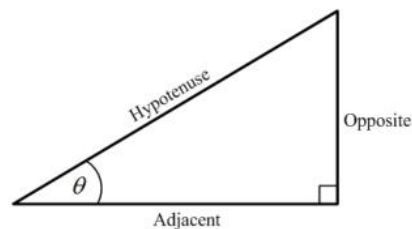

Area of triangle and  $h$  is the

Area of  $\Delta = \frac{1}{2}bh$  where  $b$  is the length of

the base

perpendicular height

$$\text{Area of } \Delta ABC = \frac{1}{2}ab \sin C$$

$$\text{Area of } \Delta ABC = \sqrt{s(s-a)(s-b)(s-c)}$$

$$\text{where } s = \frac{a+b+c}{2}$$

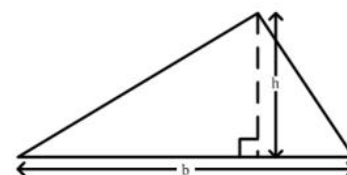

Sine rule

$$\frac{a}{\sin A} = \frac{b}{\sin B} = \frac{c}{\sin C}$$

Cosine rule

$$a^2 = b^2 + c^2 - 2bc \cos A$$

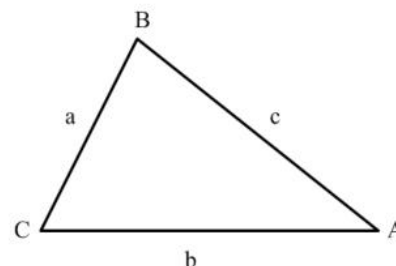

1.  $(-3)^2 + (-2)^2 =$
- (A) -13  
(B) -10  
(C) 13  
(D) 25
2. How many centimetres are there in 1.5 metres?
- (A) 0.015  
(B) 15  
(C) 150  
(D) 1500
3. Express 0.12 as a fraction in its lowest terms
- (A)  $\frac{1}{9}$   
(B)  $\frac{3}{25}$   
(C)  $\frac{1}{8}$   
(D)  $\frac{6}{50}$
4. Express  $4\frac{3}{8}$  as a decimal correct to 3 significant figures
- (A) 4.30  
(B) 4.37  
(C) 4.38  
(D) 4.40
5. 3076 in standard form is
- (A)  $3.076 \times 10^{-3}$   
(B)  $3.076 \times 10^{-2}$   
(C)  $3.076 \times 10^2$   
(D)  $3.076 \times 10^3$
6. If 60% of a number is 90, what is the number?
- (A) 30  
(B) 54  
(C) 150  
(D) 180
7. The H.C.F. of 12, 15 and 60 is
- (A) 1  
(B) 3  
(C) 12  
(D) 60
8.  $(\frac{1}{2})^3$  is the same as
- (A)  $-\frac{1}{8}$   
(B)  $-\frac{1}{6}$   
(C)  $\frac{1}{8}$   
(D)  $\frac{1}{6}$
9. If  $3n$  is an odd number, which of the following is an even number?
- (A)  $3n + 2n$   
(B)  $3n + 2$   
(C)  $3n - 2$   
(D)  $3n - 1$
10. The next term in the sequence 1, 6, 13, 22, 33 is
- (A) 44  
(B) 45  
(C) 46  
(D) 52

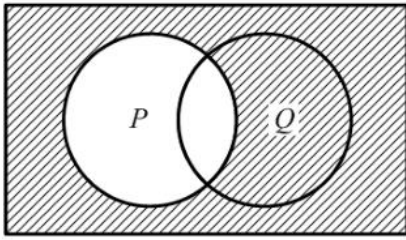

11. In the Venn diagram above, the shaded area represents
- (A)  $P'$
  - (B)  $(P \cup Q)'$
  - (C)  $Q \cup P'$
  - (D)  $Q \cap P'$
12. If  $U = \{1, 3, 5, 6, 8\}$  and  $A = \{3, 6\}$ , then the number of elements in  $A'$  is
- (A) 2
  - (B) 3
  - (C) 4
  - (D) 8
13. Which of the following sets is equivalent to  $\{a, b, c, d\}$ ?
- (A)  $\{4\}$
  - (B)  $\{a, b, c\}$
  - (C)  $\{p, q, r, s\}$
  - (D)  $\{1, 2, 3, 4, 5\}$

Item 14 refers to the Venn diagram below.

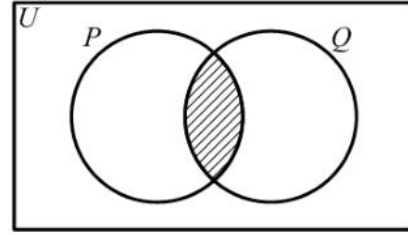

14. In the Venn diagram above, the two circles represent set P and set Q. If  $P = \{\text{Factors of } 6\}$  and  $Q = \{\text{Factors of } 4\}$ , then the shaded region represents
- (A)  $\{ \}$
  - (B)  $\{1, 2\}$
  - (C)  $\{4, 6, 8, \dots\}$
  - (D)  $\{12, 24, 36, \dots\}$
15. If TT\$6.00 is equivalent to US\$1.00, then TT\$15.00 in U.S. dollars is
- (A) \$0.25
  - (B) \$0.40
  - (C) \$2.50
  - (D) \$4.00
16. A man bought a calf for \$200 and sold it for \$250. What was his gain as a percentage of the cost price?
- (A) 5%
  - (B) 15%
  - (C) 20%
  - (D) 25%
17. During a sale, a shop allows 20% discount off the marked price of clothing. What will a customer pay for a dress with a marked price of \$30?
- (A) \$10
  - (B) \$20
  - (C) \$24
  - (D) \$30

Item 18 refers to the table below.

House Insurance	50 ¢ per \$100
Contents Insurance	25 ¢ per \$100

18. The above table shows the rates charged by an insurance company. How much will a person pay for his insurance, if his house is valued at \$50 000, and the contents at \$10 000 ?
- (A) \$225  
(B) \$275  
(C) \$450  
(D) \$500
19. How much does a customer pay for an article marked at \$50.00 if a sales tax of 6% is charged?
- (A) \$44.00  
(B) \$47.00  
(C) \$53.00  
(D) \$56.00
20. Mary invested \$200 for 3 years at 5% per annum. John invested \$300 at the same rate. If they both received the same amount of money in interest, for how many years did John invest his money?
- (A)  $1\frac{1}{2}$   
(B) 2  
(C) 3  
(D) 10
21. A company employs 12 gardeners at \$26 per day, and 8 clerks at \$17 per day. What is the mean daily wage, in dollars, of the 20 employees?
- (A) \$20.00  
(B) \$21.50  
(C) \$22.40  
(D) \$31.50
22. A man pays 60 cents for every 200 m<sup>3</sup> of gas used, plus a fixed charge of \$13.75. How much does he pay when he uses 55 000 m<sup>3</sup> of gas?
- (A) \$151.25  
(B) \$165.00  
(C) \$175.25  
(D) \$178.75
23.  $-2(x - 4) =$
- (A)  $-2x + 8$   
(B)  $-2x + 4$   
(C)  $-2x - 4$   
(D)  $-2x - 8$
24. If  $a * b = \frac{b}{a} - 1$ , then  $7 * 28 =$
- (A)  $-\frac{3}{4}$   
(B)  $\frac{1}{4}$   
(C) 3  
(D) 4
25.  $5(2x - y) - 2(3y - 5x) =$
- (A)  $-11y$   
(B)  $2x - 6y$   
(C)  $5x - 7y$   
(D)  $20x - 11y$
26. For all  $a$  and  $b$ ,
- $3a(a + 2b) - b(2a - 3b) =$
- (A)  $3a^2 + 8ab - 3b^2$   
(B)  $3a^2 + 4ab + 3b^2$   
(C)  $3a^2 + 4ab - 3b^2$   
(D)  $3a^2 - ab + 3b^2$

27.  $\frac{4}{5x} + \frac{2}{5x} =$

- (A)  $\frac{6}{25x}$   
 (B)  $\frac{8}{25x}$   
 (C)  $\frac{6}{10x}$   
 (D)  $\frac{6}{5x}$

28. Given  $2x + 3 \geq 9$ , the range of values of  $x$  is

- (A)  $x \geq 3$   
 (B)  $x > 3$   
 (C)  $x > 6$   
 (D)  $x \geq 6$

29. "When 7 is added to 3 times a certain number  $n$ , the result is 22".

The statement above may be represented by the equation

- (A)  $3n + 7 = 22$   
 (B)  $7n - 22 = 3$   
 (C)  $3n + 22 = 7$   
 (D)  $7n + 3 = 22$

30. Which of the following represents the statement "The difference of two square numbers is positive"?

- (A)  $x^2 - y^2 > 0$   
 (B)  $2x - 2y > 0$   
 (C)  $(y - x)^2 > 0$   
 (D)  $2(y - x) > 0$

31. If  $a = 3$  and  $ab = 6$ , then  $(a + b)^2 - a^2 - b^2 =$

- (A) 0  
 (B) 8  
 (C) 12  
 (D) 20

32. The volume of a cube with edges 10 cm is

- (A)  $30 \text{ cm}^3$   
 (B)  $100 \text{ cm}^3$   
 (C)  $300 \text{ cm}^3$   
 (D)  $1000 \text{ cm}^3$

33. 2500 millimetres expressed in metres is

- (A) 0.25  
 (B) 2.5  
 (C) 25  
 (D) 250

34. The lengths of the sides of a triangle are  $x$ ,  $2x$  and  $2x$  centimetres. If the perimeter is 20 centimetres, what is the value of  $x$ ?

- (A) 10  
 (B) 8  
 (C) 5  
 (D) 4

35. A car travels 80 kilometres in  $2\frac{1}{2}$  hours. What is its speed in kilometers per hour?

- (A) 6  
 (B) 32  
 (C) 82.5  
 (D) 200

Item 36 refers to the diagram below.

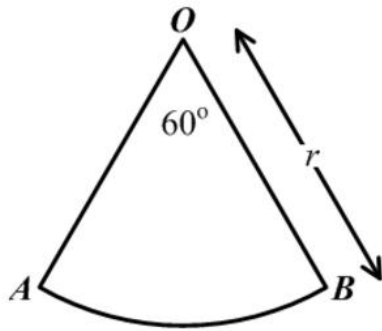

36.  $AOB$  is a sector of a circle such that angle  $AOB = 60^\circ$  and  $OB$  is  $r$  units long. The area of  $AOB$  is

- (A)  $\frac{1}{3}\pi r$
- (B)  $\frac{1}{6}\pi r$
- (C)  $\frac{1}{3}\pi r^2$
- (D)  $\frac{1}{6}\pi r^2$

37. Fifty guests each had 2 glasses of champagne. Each glass held 150 millilitres. How many litres of champagne were used?

- (A) 0.15
- (B) 1.5
- (C) 15
- (D) 150

38. The area of a rectangle is  $53.6 \text{ cm}^2$ . If the length is multiplied by four and the width is halved, the area would then be

- (A)  $26.8 \text{ cm}^2$
- (B)  $53.6 \text{ cm}^2$
- (C)  $107.2 \text{ cm}^2$
- (D)  $214.4 \text{ cm}^2$

39. A boy leaves home at 09:15 hours and arrives at school at 10:05 hours. If he travels non-stop at an average speed of  $6 \text{ kmh}^{-1}$ , how many km is his home from school?

- (A) 2 km
- (B) 5 km
- (C) 6 km
- (D) 9 km

40. The marks obtained by ten students in a test marked out of 25 were:

14, 22, 15, 19, 19, 16, 24, 13, 20, 19

The range of marks was

- (A) 11
- (B) 13
- (C) 18
- (D) 19

Item 41 refers to the following table.

Mark	Frequency	Mark x Frequency
1	2	2
2	3	6
3	5	15
4	4	16
5	$x$	$y$
Total		49

41. The table shows the frequency distribution of the marks a student obtained on a test. How often did the student score 5 marks?

- (A) 2
- (B) 5
- (C) 10
- (D) 49

Item 42 refers to the following bar chart

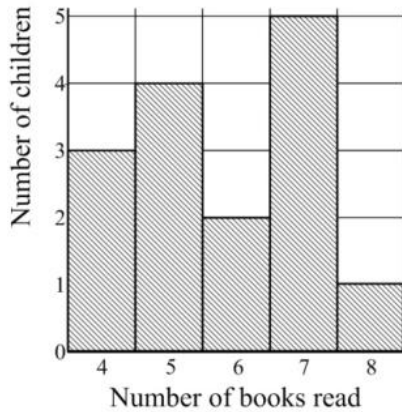

42. The bar chart above shows the number of books read by the children who took part in a survey.

How many children took part in the survey?

- (A) 5
- (B) 15
- (C) 75
- (D) 87

Item 43 refers to the following table.

Length of Leaf (cm)	10-14	15-19	20-24	25-29
Frequency	3	8	12	7

43. The lengths of 30 cabbage leaves were measured, to the nearest cm, and the information grouped as shown in the table above.

The class boundaries are

- (A) 3, 8, 12, 7
- (B) 5, 5, 5, 5
- (C) 10, 14, 15, 19, 20, 24, 25, 29
- (D) 9.5, 14.5, 19.5, 24.5, 29.5

Item 44 refers to the pie-chart below.

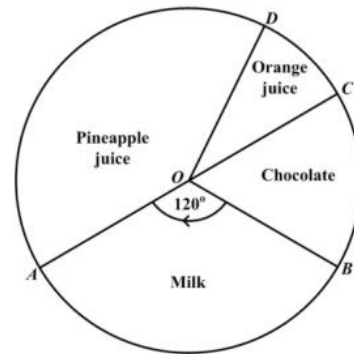

44. The pie chart shows the preference in drinks of a group of students. If 12 students prefer chocolate, then the total number of students is

- (A) 48
- (B) 72
- (C) 180
- (D) 360

45. A boy throws a die twice. What is the probability that he will get a three followed by an even number?

- (A)  $\frac{1}{12}$
- (B)  $\frac{1}{4}$
- (C)  $\frac{5}{12}$
- (D)  $\frac{7}{12}$

Item 46 refers to the arrow diagram below

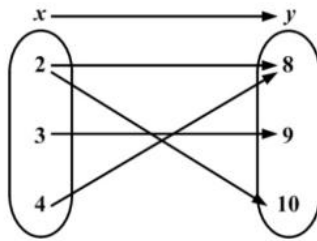

46. The arrow diagram above describes the relation

- (A)  $x$  is a factor of  $y$
- (B)  $x$  is less than  $y$
- (C)  $x$  is a multiple of  $y$
- (D)  $x$  is greater than  $y$

47. If  $f(x) = x^2 - x - 1$ , then  $f(-5) =$

- (A) -31
- (B) 29
- (C) 24
- (D) 31

48. Which of the following diagrams illustrates a function?

- (A)
- (B)
- (C)
- (D)

49.

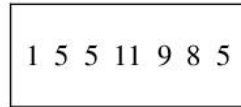

The median of the set of numbers above is

- (A) 5
- (B) 6
- (C) 8
- (D) 9

Item 50 refers to the following diagram.

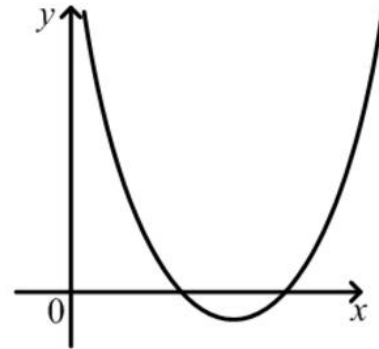

50. The diagram above shows a graph. If  $a$ ,  $b$  and  $c$  are constants, the equation of the graph could be

- (A)  $y = ax^2 + c$
- (B)  $y = c - ax^2$
- (C)  $y = c + bx - ax^2$
- (D)  $y = ax^2 + bx + c$

51. Which of the following sets is represented by the relation  $f : x \rightarrow x^2 + 3$ ?

- (A)  $\{(0, 3), (1, 4), (2, 7), (3, 12)\}$
- (B)  $\{(0, 3), (1, 5), (2, 7), (3, 9)\}$
- (C)  $\{(0, 3), (1, 4), (2, 5), (3, 6)\}$
- (D)  $\{(0, 3), (1, 1), (2, 4), (3, 9)\}$

52. A boat was travelling on a bearing of  $270^{\circ}$ . In what direction was it travelling?
- (A) West
  - (B) East
  - (C) North
  - (D) South

Item 53 refers to the diagram below of a construction. With centre  $A$ , an arc  $BC$  is drawn. With centre  $B$ , and the same radius, the arc  $PCQ$  is drawn.

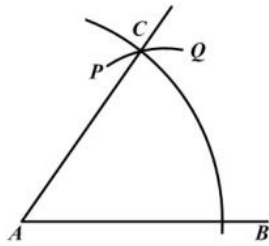

53. What is the measure of  $\angle BAC$ ?
- (A)  $30^{\circ}$
  - (B)  $45^{\circ}$
  - (C)  $60^{\circ}$
  - (D)  $75^{\circ}$

54. A ship sailed 8 km due east from  $A$  to  $B$ . It then sailed 6 km due north to  $C$ . Which diagram below BEST represents the path of the ship?

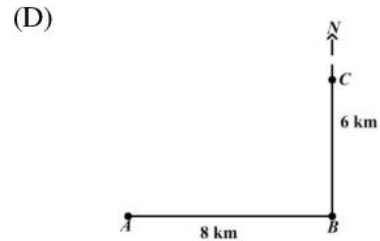
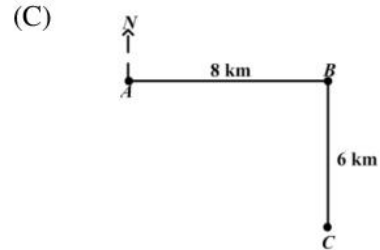
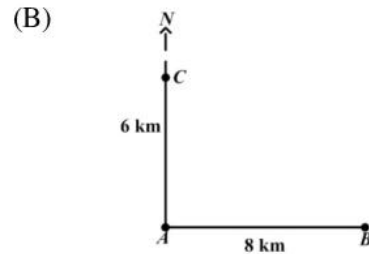
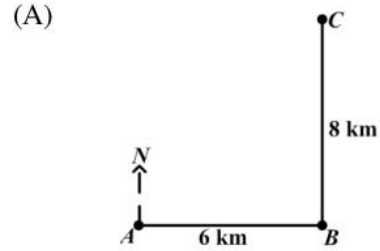

55. In each of the diagrams shown below,  $A'$  is the image of  $A$ . Which of the following diagrams shows a reflection in the  $x$ -axis?

(A)

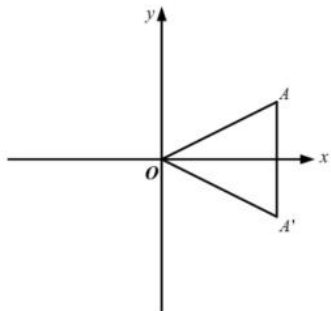

(B)

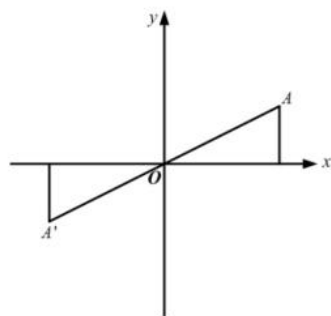

(C)

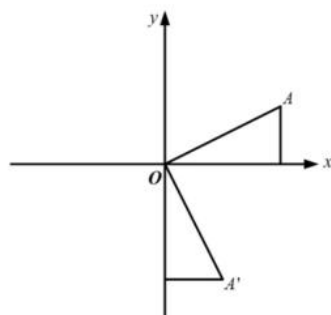

(D)

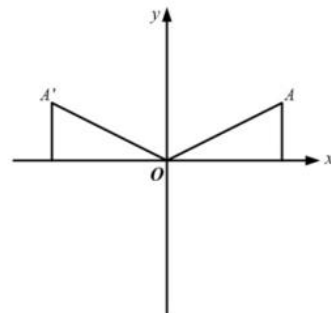

Item 56 refers to the following diagram.

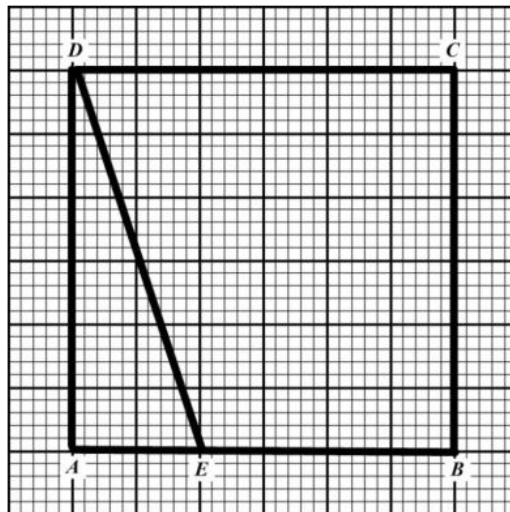

56. How many triangles congruent to  $\triangle ADE$  would be needed to cover the rectangle  $ABCD$  entirely?

- (A) 2
- (B) 4
- (C) 6
- (D) 8

Item 57 refers to the following diagram.

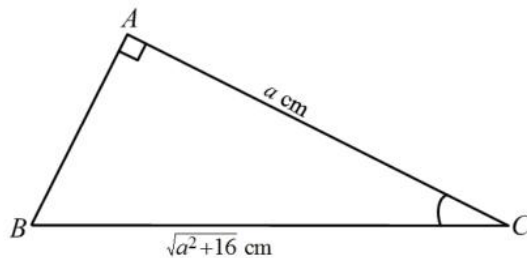

57. The length, in cm, of  $AB$  is

- (A) 4
- (B)  $a$
- (C)  $a + 4$
- (D)  $a - 4$

58.

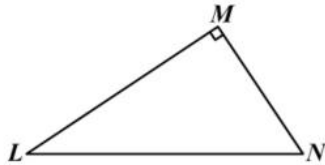

The triangle  $LMN$  above is rotated in a clockwise direction about  $L$  through an angle of  $90^\circ$ . What is its image?

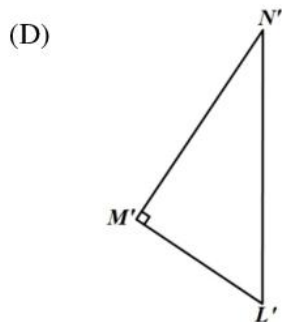
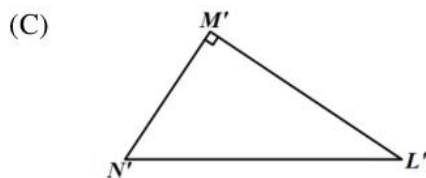
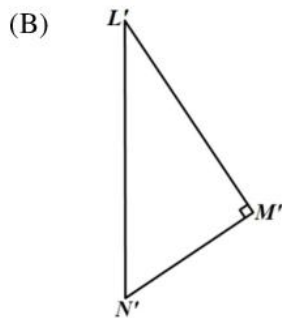
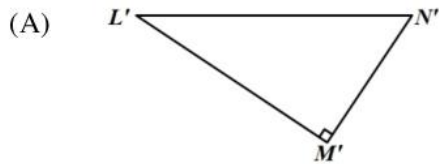

Item 59 refers to the following diagram.

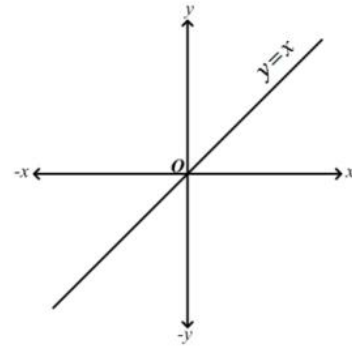

59. In the diagram above, if the line  $y = x$  is rotated anti-clockwise about  $O$  through  $90^\circ$ , what is its image?

- (A)  $y = 0$
- (B)  $x = 0$
- (C)  $y = x$
- (D)  $y = -x$

Item 60 refers to the diagram below

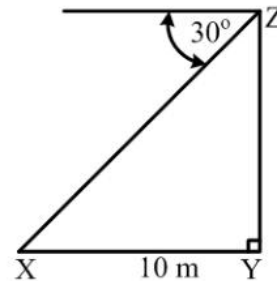

60. The diagram above, **not drawn to scale**, shows the angle of depression of a point  $X$  from  $Z$  is  $30^\circ$ . If  $X$  is 10 metres from  $Y$ , the height of  $YZ$ , in metres, is

- (A)  $10 \tan 30^\circ$
- (B)  $10 \sin 30^\circ$
- (C)  $10 \cos 30^\circ$
- (D)  $10 \cos 60^\circ$

**IF YOU FINISH BEFORE TIME IS CALLED, CHECK YOUR WORK ON THIS TEST.**

↑ AFFIX SEAL HERE ↑

**CANDIDATE –PLEASE NOTE!**

You must sign below and return this booklet with the Answer Sheet. Failure to do so may result in disqualification.

\_\_\_\_\_  
SignatureTEST CODE **01234010**

MAY/JUNE 2008

**FORM TP 2007104**

**CARIBBEAN EXAMINATIONS COUNCIL**  
**SECONDARY EDUCATION CERTIFICATE**  
**EXAMINATION**  
**MATHEMATICS**  
**Paper 01 – General Proficiency**  
*90 minutes*

21 MAY 2008 (p.m.)

**READ THE FOLLOWING DIRECTIONS CAREFULLY**

1. In addition to this test booklet, you should have an answer sheet.
2. Calculators and mathematical tables may NOT be used for this paper.
3. **A list of formulae is provided on page 2 of this booklet.**
4. This test consists of 60 items. You will have 90 minutes to answer them.
5. Each item in this test has four suggested answers, lettered (A), (B), (C), (D). Read each item you are about to answer, and decide which choice is best.
6. On your answer sheet, find the number which corresponds to your item and blacken the space having the same letter as the answer you have chosen. Look at the sample item below.

Sample Item

$2a + 6a =$

- (A)  $8a$   
 (B)  $8a^2$   
 (C)  $12a$   
 (D)  $12a^2$

Sample Answer

The best answer to this item is “8a”, so answer space (A) has been blackened.

7. If you want to change your answer, erase your old answer completely and fill in your new choice.
8. When you are told to begin, turn the page and work as quickly and as carefully as you can. If you cannot Answer an item, omit it and go on to the next one. You can return later to the item omitted. Your score will be the total number of correct answers.
9. You may do any rough work in the booklet.
10. Do not be concerned that the answer sheet provides spaces for more answers than there are items in this test.

**DO NOT TURN THIS PAGE UNTIL YOU ARE TOLD TO DO SO.**

Copyright © 2006 Caribbean Examinations Council ®.

**LIST OF FORMULAE**

Volume of a prism  $V = Ah$  where  $A$  is the area of a cross-section and  $h$  is the perpendicular length.

Volume of a cylinder  $V = \pi r^2 h$  where  $r$  is the radius of the base and  $h$  is the perpendicular height.

Volume of a right pyramid  $V = \frac{1}{3}Ah$  where  $A$  is the area of the base and  $h$  is the perpendicular height.

Circumference  $C = 2\pi r$  where  $r$  is the radius of the circle.

Area of a circle  $A = \pi r^2$  where  $r$  is the radius of the circle.

Area of Trapezium  $A = \frac{1}{2}(a+b)h$  where  $a$  and  $b$  are the lengths of the parallel sides and  $h$  is the perpendicular distance between the parallel sides.

Roots of quadratic equations If  $ax^2 + bx + c = 0$ ,  
 then  $x = \frac{-b \pm \sqrt{b^2 - 4ac}}{2a}$

Trigonometric ratios

$$\sin \theta = \frac{\text{opposite side}}{\text{hypotenuse}}$$

$$\cos \theta = \frac{\text{adjacent side}}{\text{hypotenuse}}$$

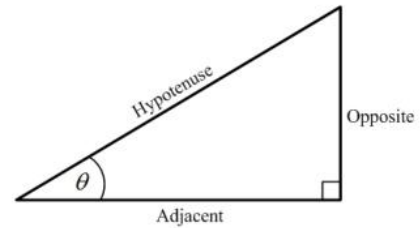
$$\tan \theta = \frac{\text{opposite side}}{\text{adjacent side}}$$

Area of triangle Area of  $\Delta = \frac{1}{2}bh$  where  $b$  is the length of the base and  $h$  is the perpendicular height

$$\text{Area of } \Delta ABC = \frac{1}{2}ab \sin C$$

$$\text{Area of } \Delta ABC = \sqrt{s(s-a)(s-b)(s-c)}$$

$$\text{where } s = \frac{a+b+c}{2}$$

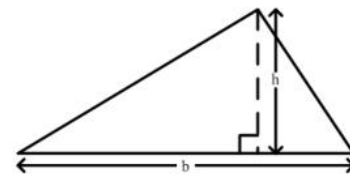

Sine rule  $\frac{a}{\sin A} = \frac{b}{\sin B} = \frac{c}{\sin C}$

Cosine rule  $a^2 = b^2 + c^2 - 2bc \cos A$

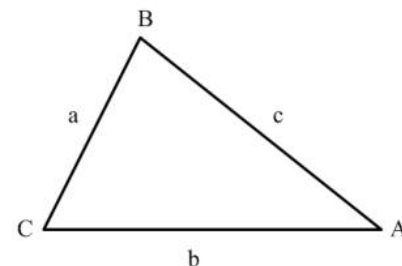

1.  $18.96 \times 2.03$  correct to two significant figures equals
- (A) 0.38  
(B) 38  
(C) 38.10  
(D) 380
2.  $11.1 \div 0.01$  is equal to
- (A) 110  
(B) 111  
(C) 1 100  
(D) 1 110
3. In scientific notation, 170.04 is written as
- (A)  $0.17004 \times 10^3$   
(B)  $1.7004 \times 10^2$   
(C)  $17.004 \times 10^1$   
(D)  $1.7004 \times 10^{-1}$
4. The number 3.14063 written correct to 3 decimal places is
- (A) 3.140  
(B) 3.141  
(C) 3.146  
(D) 3.150
5. Express 0.12 as a fraction in its LOWEST terms
- (A)  $\frac{1}{8}$   
(B)  $\frac{1}{9}$   
(C)  $\frac{3}{25}$   
(D)  $\frac{6}{50}$
6. The EXACT value of  $\frac{37.26 \div 1.8}{1000}$  is
- (A) 0.207  
(B) 0.0207  
(C) 20.7000  
(D) 20 700
7. What is the value of the digit 3 in the number 2341?
- (A) 3  
(B) 30  
(C) 300  
(D) 3000
8. What is the HIGHEST common factor of the set of numbers {54, 72, 90}?
- (A) 9  
(B) 18  
(C) 90  
(D) 1080
9.  $25 \times 130$  is the same as
- (A)  $(25 \times 100) + 30$   
(B)  $(25 + 30) \times 100$   
(C)  $(25 \times 30) + (25 \times 100)$   
(D)  $(100 \times 30) + (100 \times 25)$
10. The LARGEST prime number that is less than 100 is
- (A) 91  
(B) 93  
(C) 97  
(D) 99

11. Of a class of 32 students, 17 study Music and 20 study Art. What is the LEAST number of students who are studying BOTH Music and ART?

- (A) 3
- (B) 5
- (C) 12
- (D) 15

12. Which of the following sets is defined by  $\{x \in \mathbb{Z} : -2 \leq x \leq 4\}$ ?

- (A)  $\{0, 1, 2, 3, 4\}$
- (B)  $\{1, 2, 3, 4\}$
- (C)  $\{-1, 0, 1, 2, 3\}$
- (D)  $\{-2, -1, 0, 1, 2, 3, 4\}$

Item 13 refers to the Venn diagram below.

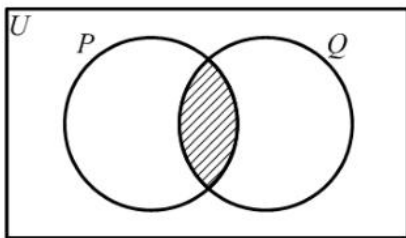

13. The two circles above represent set  $P$  and set  $Q$ . If  $P = \{\text{Factors of } 6\}$  and  $Q = \{\text{Factors of } 4\}$ , then the shaded region represents

- (A)  $\{\}$
- (B)  $\{1, 2\}$
- (C)  $\{4, 6, 8, \dots\}$
- (D)  $\{12, 24, 36, \dots\}$

Item 14 refers to the Venn diagram below.

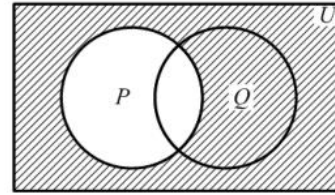

14. In the Venn diagram above, the shaded area represents

- (A)  $P'$
- (B)  $(P \cup Q)'$
- (C)  $Q \cap P'$
- (D)  $Q \cup P'$

15. If the simple interest on \$800 for 3 years is \$54, what is the rate of interest per annum?

- (A) 44%
- (B) 5%
- (C)  $2\frac{1}{4}\%$
- (D)  $\frac{4}{9}\%$

16.  $3\frac{1}{4}\%$  of \$500 is

- (A) \$ 1.62
- (B) \$15.52
- (C) \$16.00
- (D) \$16.25

17. Mary invested \$200 for 3 years at 5% per annum. John invested \$300 at the same rate. If they both received the same amount of money in interest, for how many years did John invest his money?
- (A) 2  
(B) 3  
(C) 5  
(D) 10
18. A television set costs \$350 cash. When bought on hire purchase, a deposit of \$35 is required, followed by 12 monthly payments of \$30. How much is saved by paying cash?
- (A) \$10  
(B) \$25  
(C) \$40  
(D) \$45
19. How much does a customer pay for an article marked at \$50.00 if a sales tax of 6% is charged?
- (A) \$44.00  
(B) \$47.00  
(C) \$53.00  
(D) \$56.00
20. If \$7000 is borrowed at the rate of 5% per annum for 3 years, the simple interest is
- (A) \$ 105  
(B) \$ 210  
(C) \$ 370  
(D) \$1 050
21. If the sale of an article resulted in a loss of 20 per cent on the cost price, then the cost price as a percentage of the selling price is
- (A) 75%  
(B) 80%  
(C) 120%  
(D) 125%
22. A salesman sells a car for \$11 000. If he is paid a commission of 4.5% for the first \$10 000 and 7.5% on the remainder, then the commission he receives is
- (A) \$ 495  
(B) \$ 525  
(C) \$ 825  
(D) \$1 320
23. A loan of \$8 000 was paid back in 2 years with monthly payments of \$400.00. The percentage profit on the loan was
- (A) 5%  
(B)  $8\frac{1}{3}\%$   
(C)  $16\frac{2}{3}\%$   
(D) 20%
24.  $5(x + y) - 3(x - y) =$
- (A)  $2x$   
(B)  $2x + 2y$   
(C)  $2x + 8y$   
(D)  $8x + 8y$
25. If  $r * s = s^r$  then  $3 * 2 =$
- (A) 8  
(B) 9  
(C) 12  
(D) 27
26. If  $m * n = \sqrt{mn - n^2}$ , then  $5 * 3 =$
- (A)  $\sqrt{6}$   
(B) 3  
(C)  $\sqrt{15}$   
(D) 6

27.  $(4 - x)(3 + 2x) =$

- (A)  $7 + 5x - 2x^2$   
 (B)  $12 + 5x + 2x^2$   
 (C)  $12 + 11x - 2x^2$   
 (D)  $12 + 5x - 2x^2$

28. For  $2x + 3 \geq 9$ , the range of values of  $x$  is

- (A)  $x \geq 3$   
 (B)  $x > 3$   
 (C)  $x \geq 6$   
 (D)  $x > 6$

29. If  $x = -2$ ,  $y = 3$ ,  $t = 2$ , then  $\left(\frac{x}{y}\right)^t =$

- (A)  $-\frac{4}{9}$   
 (B)  $\frac{4}{9}$   
 (C)  $\frac{4}{3}$   
 (D)  $\frac{9}{4}$

30. If  $m = \frac{1}{2}$ ,  $n = -\frac{1}{4}$ , then  $m^2 + n^2 =$

- (A)  $\frac{1}{16}$   
 (B)  $\frac{3}{16}$   
 (C)  $\frac{5}{16}$   
 (D)  $\frac{7}{16}$

31. The values of  $x$  and  $y$  which satisfy the equations  $x + 2y = 27$  and  $2x - y = 19$  are respectively

- (A) 15 and 10  
 (B) 10 and 15  
 (C) 7 and 13  
 (D) 13 and 7

32. A rectangular picture frame has a border area of  $32 \text{ cm}^2$ . Given that the external dimensions are  $10 \text{ cm} \times 8 \text{ cm}$ , what are the MOST likely dimensions of the picture?

- (A)  $8 \text{ cm} \times 6 \text{ cm}$   
 (B)  $8 \text{ cm} \times 4 \text{ cm}$   
 (C)  $8 \text{ cm} \times 10 \text{ cm}$   
 (D)  $8 \text{ cm} \times 14 \text{ cm}$

33. The diagram below shows a cylinder with diameter 6 cm and height 20 cm.

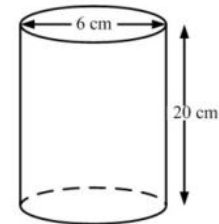

The volume, in  $\text{cm}^3$ , of the cylinder is

- (A)  $180\pi$   
 (B)  $240\pi$   
 (C)  $360\pi$   
 (D)  $720\pi$

34. The distance around the edge of a circular pond is 88 m. The radius, in metres, is

- (A)  $176\pi$   
 (B)  $88\pi$   
 (C)  $\frac{88}{\pi}$   
 (D)  $\frac{88}{2\pi}$

35. 2500 millimetres expressed in metres is
- (A) 0.25  
 (B) 2.5  
 (C) 25  
 (D) 250

Item 36 refers to the trapezium below.

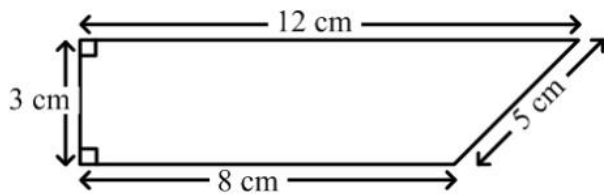

36. The area of the trapezium above is
- (A)  $24 \text{ cm}^2$   
 (B)  $28 \text{ cm}^2$   
 (C)  $30 \text{ cm}^2$   
 (D)  $36 \text{ cm}^2$
37. A motorist travelled 60 km in 1 hour and a further 90 km in 2 hours. His average speed, in km/hr, for the entire journey was
- (A) 30  
 (B) 50  
 (C) 75  
 (D) 150

Item 38 refers to the following diagram.

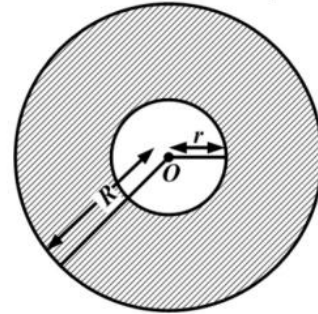

38. The diagram shows two concentric circles centre  $O$  with radius  $r$  cm and  $R$  cm. The area, in  $\text{cm}^2$ , of the shaded region is
- (A)  $\pi R^2$   
 (B)  $\pi r^2$   
 (C)  $\pi R^2 - \pi r^2$   
 (D)  $\pi r^2 - R^2$
39. The area of a triangle is  $30 \text{ cm}^2$  and its base is 10 cm. What is the perpendicular height, in cm, of the triangle?
- (A) 6  
 (B) 12  
 (C) 13  
 (D) 17
40. Tom leaves town  $P$  to drive to town  $Q$ , which is 595 km away, at 0600 hrs. He arrives in town  $Q$  at 1300 hrs the same day. Tom's average speed was
- (A) 70 km/h  
 (B) 75 km/h  
 (C) 85 km/h  
 (D) 90 km/h

Items 41-42 refer to the diagram below showing the number of persons who listen to Radio Stations A, B, C and D during the week

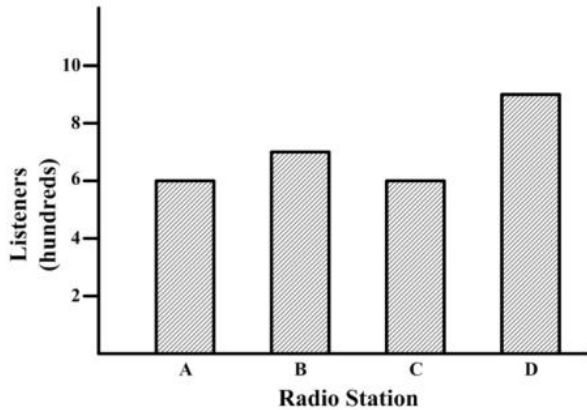

41. Which two stations **together** have MORE THAN 1500 listeners during the week?
- (A) A and B  
 (B) A and D  
 (C) C and D  
 (D) B and D
42. Which station had as many listeners during the week as the mean number of listeners for the four stations during the week?
- (A) Station A  
 (B) Station B  
 (C) Station C  
 (D) Station D

Item 43 refers to the scores below.

10	15	4	7
8	8	1	4

43. The median of the eight scores presented above is
- (A) 4  
 (B) 7.25  
 (C) 7.50  
 (D) 8

Item 44 refers to the diagram below

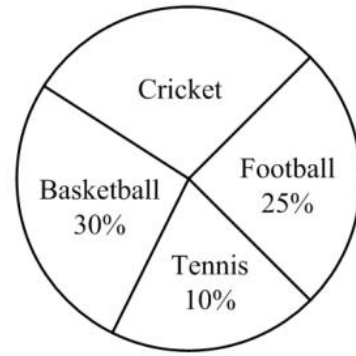

44. The pie chart shows the popular games played at a school of 720 students. How many play cricket?
- (A) 35  
 (B) 120  
 (C) 252  
 (D) 300
45. The heights in cm, of ten students are 150, 152, 155, 153, 170, 160, 156, 165, 158, 155. The range is
- (A) 5  
 (B) 20  
 (C) 150  
 (D) 155
46. Which of the following represents the equation of a straight line?

- (A)  $y = 2x + 3$   
 (B)  $y = \frac{4}{x}$   
 (C)  $y = x^2 - 4$   
 (D)  $y = x^2 + 2x - 5$

Item 47 refers to the graph below

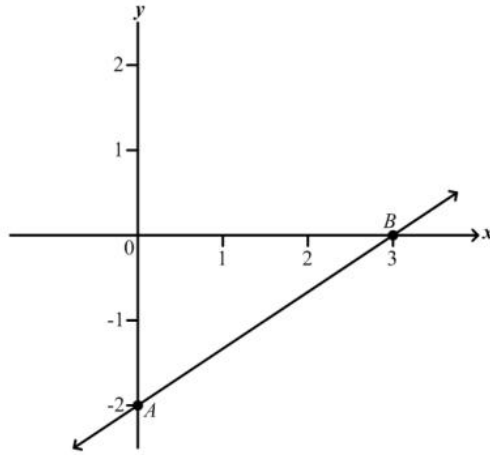

47. The straight line  $AB$  cuts the  $Y$  axis at
- (A)  $(0, 3)$
  - (B)  $(0, 2)$
  - (C)  $(3, -2)$
  - (D)  $(0, -2)$

Item 48 refers to the graph below

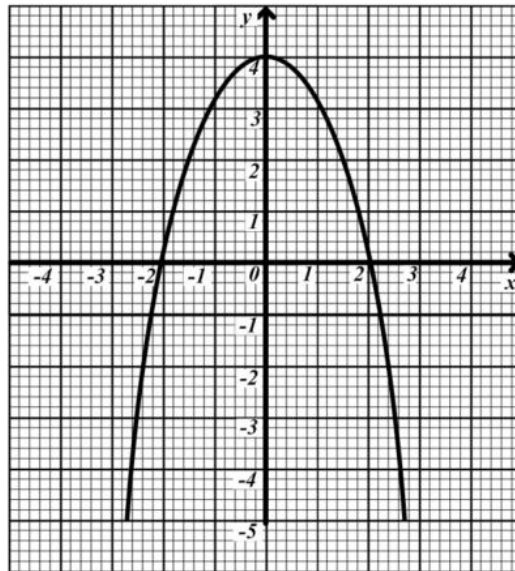

48. From the graph, the values of  $x$  when  $y = -1$  are
- (A) 1 and -1
  - (B) 2.2 and -2.2
  - (C) 2.5 and -2.5
  - (D) 2.8 and -2.8

Items 49-50 refer to the following graph

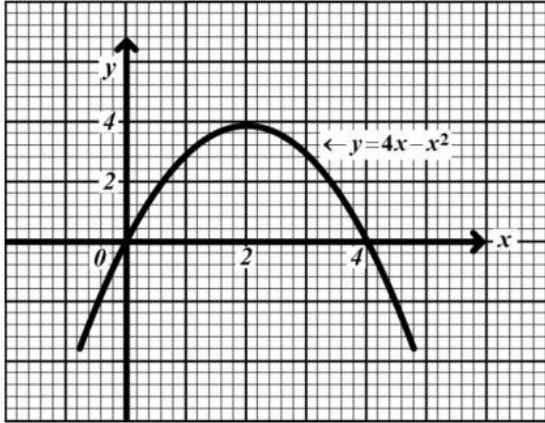

49. The maximum point of  $y = 4x - x^2$  is

- (A) (0, 0)
- (B) (0, 4)
- (C) (2, 4)
- (D) (4, 2)

50. The values of  $x$  for which  $y = 4x - x^2$  intersects  $y = 0$  are

- (A)  $x = 0$  and  $x = 4$
- (B)  $x = 0$  and  $x = 2$
- (C)  $x = 0$  and  $x = -4$
- (D)  $x = 2$  and  $x = 4$

Item 51 refers to the following graph.

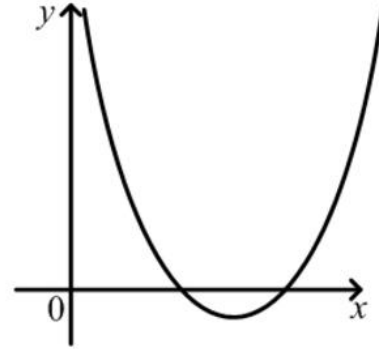

51. If  $a$ ,  $b$  and  $c$  are constants and  $a > 0$ , the equation of the graph could be

- (A)  $y = ax^2 + c$
- (B)  $y = c - ax^2$
- (C)  $y = c + bx - ax^2$
- (D)  $y = ax^2 + bx + c$

Item 52 refers to the diagram below.

$AC$  and  $DE$  are straight lines intersecting at  $B$ .  
Angle  $DBA = 58^\circ$

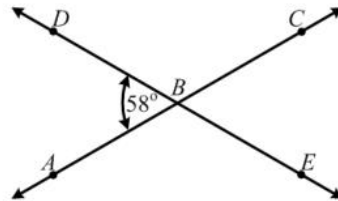

52. The measure of angle  $ABE$  is

- (A)  $58^\circ$
- (B)  $122^\circ$
- (C)  $142^\circ$
- (D)  $302^\circ$

Item 53 refers to the diagram below.

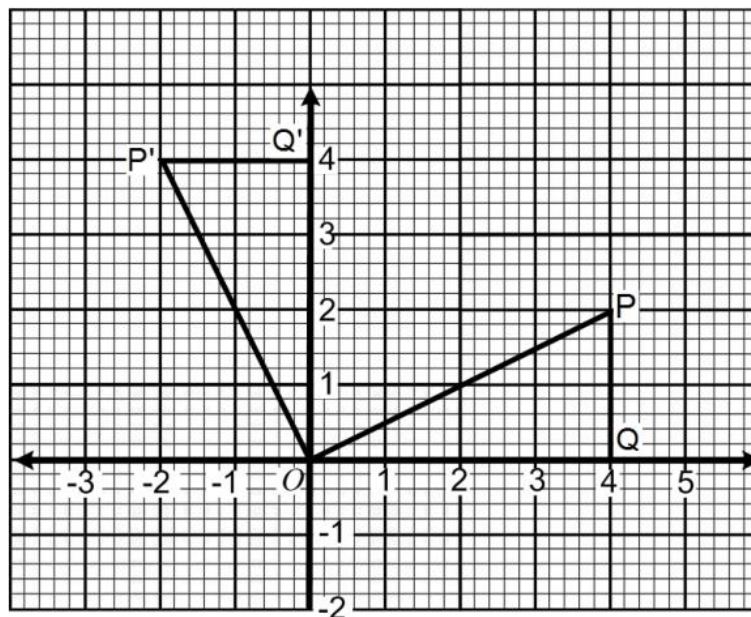

53. In the figure above,  $\triangle OPQ$  is mapped to  $\triangle OP'Q'$ . What type of transformation has taken place?
- (A) Reflection
  - (B) Enlargement
  - (C) Translation
  - (D) Rotation

54. A ship sailed 8 km due east from A to B. It then sailed 6 km due north to C. Which diagram below BEST represents the path of the ship?

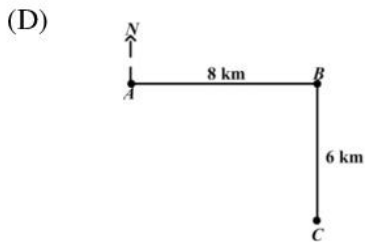
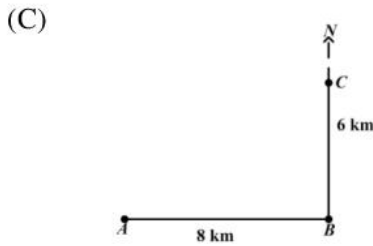
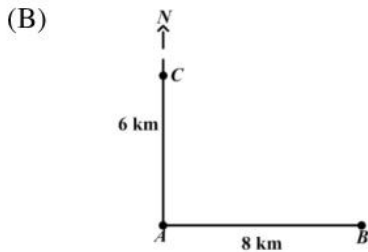
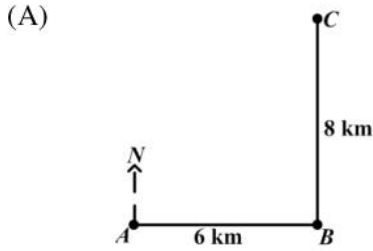

Item 55 refers to the diagram below.

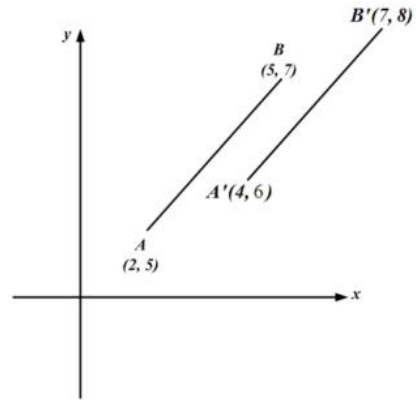

55. In the diagram, the translation by which  $AB$  is mapped to  $A'B'$  is represented by

- (A)  $\begin{pmatrix} 2 \\ 1 \end{pmatrix}$   
 (B)  $\begin{pmatrix} 2 \\ 3 \end{pmatrix}$   
 (C)  $\begin{pmatrix} 3 \\ 2 \end{pmatrix}$   
 (D)  $\begin{pmatrix} 5 \\ 3 \end{pmatrix}$

Item 56 refers to the diagram below.

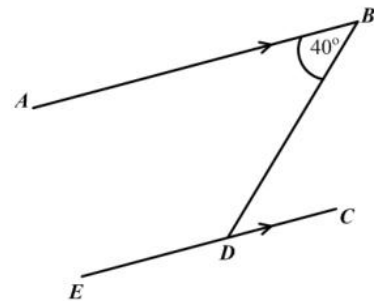

56.  $AB$  is parallel to  $EC$ . The measure of  $\angle BDE$  is

- (A)  $40^\circ$   
 (B)  $50^\circ$   
 (C)  $140^\circ$   
 (D)  $180^\circ$

Item 57 refers to the following diagram.

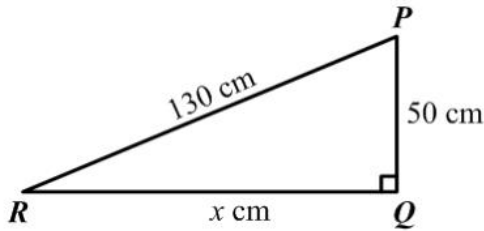

57. In the right-angled triangle above, **not drawn to scale**,  $\hat{Q} = 90^\circ$ ,  $PQ = 50$  cm,  $PR = 130$  cm and  $RQ = x$  cm.

$\tan \hat{P}RQ =$

- (A)  $\frac{50}{x}$
- (B)  $\frac{x}{50}$
- (C)  $\frac{50}{130}$
- (D)  $\frac{x}{130}$

58. Which of the following BEST describes the properties of an equilateral triangle?

- I. All sides are equal
- II. All angles are equal
- III. Only two sides are equal
- IV. Only two angles are equal

- (A) I and II
- (B) II and III
- (C) III only
- (D) IV only

Item 59 refers to the diagram below.

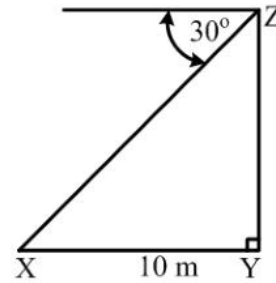

59. The diagram above, not drawn to scale, shows that the angle of depression of a point X from Z is  $30^\circ$ . If X is 10 metres from Y, the height of YZ, in metres, is

- (A)  $10 \tan 30^\circ$
- (B)  $10 \sin 30^\circ$
- (C)  $10 \cos 30^\circ$
- (D)  $10 \cos 60^\circ$

Item 60 refers to the following graph which shows the point A

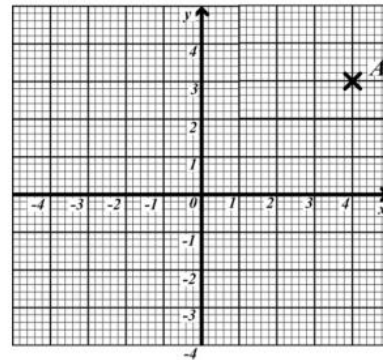

60. What are the co-ordinates of the image of A under reflection in the y – axis?

- (A)  $(-3, 4)$
- (B)  $(3, -4)$
- (C)  $(4, -3)$
- (D)  $(-4, 3)$

**IF YOU FINISH BEFORE TIME IS CALLED, CHECK YOUR WORK ON THIS TEST.**



↑ AFFIX SEAL HERE ↑

**CANDIDATE –PLEASE NOTE!**

You must sign below and return this booklet with the Answer Sheet. Failure to do so may result in disqualification.

\_\_\_\_\_  
SignatureTEST CODE **01234010**

MAY/JUNE 2009

**FORM TP 2007104**

**C A R I B B E A N   E X A M I N A T I O N S   C O U N C I L**  
**S E C O N D A R Y   E D U C A T I O N   C E R T I F I C A T E**  
**E X A M I N A T I O N**  
**M A T H E M A T I C S**  
**P a p e r   0 1 – G e n e r a l   P r o f i c i e n c y**  
*9 0   m i n u t e s*

20 MAY 2009 (p.m.)

**READ THE FOLLOWING DIRECTIONS CAREFULLY**

1. In addition to this test booklet, you should have an answer sheet.
2. Calculators and mathematical tables may NOT be used for this paper.
3. **A list of formulae is provided on page 2 of this booklet.**
4. This test consists of 60 items. You will have 90 minutes to answer them.
5. Each item in this test has four suggested answers, lettered (A), (B), (C), (D). Read each item you are about to answer, and decide which choice is best.
6. On your answer sheet, find the number which corresponds to your item and blacken the space having the same letter as the answer you have chosen. Look at the sample item below.

Sample Item

$2a + 6a =$

- (A)  $8a$   
 (B)  $8a^2$   
 (C)  $12a$   
 (D)  $12a^2$

Sample Answer

The best answer to this item is “ $8a$ ”, so answer space (A) has been blackened.

7. If you want to change your answer, erase your old answer completely and fill in your new choice.
8. When you are told to begin, turn the page and work as quickly and as carefully as you can. If you cannot Answer an item, omit it and go on to the next one. You can return later to the item omitted. Your score will be the total number of correct answers.
9. You may do any rough work in the booklet.
10. Do not be concerned that the answer sheet provides spaces for more answers than there are items in this test.

**DO NOT TURN THIS PAGE UNTIL YOU ARE TOLD TO DO SO.**

Copyright © 2009 Caribbean Examinations Council ®.

**LIST OF FORMULAE**

Volume of a prism  $V = Ah$  where  $A$  is the area of a cross-section and  $h$  is the perpendicular length.

Volume of a cylinder  $V = \pi r^2 h$  where  $r$  is the radius of the base and  $h$  is the perpendicular height.

Volume of a right pyramid  $V = \frac{1}{3} Ah$  where  $A$  is the area of the base and  $h$  is the perpendicular height.

Circumference  $C = 2\pi r$  where  $r$  is the radius of the circle.

Area of a circle  $A = \pi r^2$  where  $r$  is the radius of the circle.

Area of Trapezium  $A = \frac{1}{2}(a + b)h$  where  $a$  and  $b$  are the lengths of the parallel sides and  $h$  is the perpendicular distance between the parallel sides.

Roots of quadratic equations If  $ax^2 + bx + c = 0$ ,  
 then  $x = \frac{-b \pm \sqrt{b^2 - 4ac}}{2a}$

Trigonometric ratios

$\sin \theta = \frac{\text{opposite side}}{\text{hypotenuse}}$

$\cos \theta = \frac{\text{adjacent side}}{\text{hypotenuse}}$

$\tan \theta = \frac{\text{opposite side}}{\text{adjacent side}}$

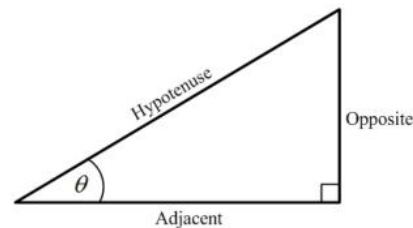

Area of triangle Area of  $\Delta = \frac{1}{2}bh$  where  $b$  is the length of the base and  $h$  is the perpendicular height

Area of  $\Delta ABC = \frac{1}{2} ab \sin C$

Area of  $\Delta ABC = \sqrt{s(s-a)(s-b)(s-c)}$

where  $s = \frac{a+b+c}{2}$

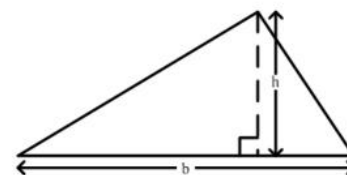

Sine rule  $\frac{a}{\sin A} = \frac{b}{\sin B} = \frac{c}{\sin C}$

Cosine rule  $a^2 = b^2 + c^2 - 2bc \cos A$

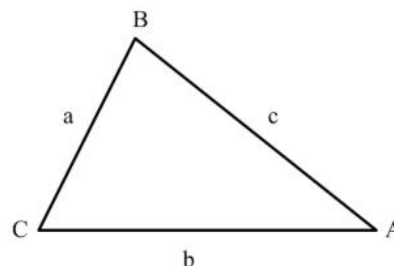

1.  $(-3)^2 + (-2)^2 =$
- (A) -13  
(B) -10  
(C) 13  
(D) 25
2. Written in scientific notation,  $0.045 \times 10^{-3}$  is
- (A)  $4.5 \times 10^{-6}$   
(B)  $4.5 \times 10^{-5}$   
(C)  $4.5 \times 10^{-4}$   
(D)  $4.5 \times 10^{-1}$
3. What percentage of 30 is 6 ?
- (A) 5%  
(B) 18%  
(C) 20%  
(D) 150%
4.  $11.1 \div 0.01$  is equal to
- (A) 110  
(B) 111  
(C) 1100  
(D) 1110
5. If \$560 is shared in the ratio 2:3:9, the difference between the largest and the smallest shares is
- (A) \$ 80  
(B) \$240  
(C) \$280  
(D) \$360
6. If 60% of a number is 90, what is the number?
- (A) 30  
(B) 54  
(C) 150  
(D) 180
7. What is the value of the digit 2 in the number 48.621?
- (A)  $\frac{2}{100}$   
(B)  $\frac{2}{10}$   
(C) 2  
(D) 200
8. The number 301 can be written as
- (A)  $3 \times 10^2 + 1$   
(B)  $3 \times 10^3 + 1$   
(C)  $3 \times 10^2 + 1 \times 10$   
(D)  $3 \times 10^3 + 1 \times 10$
9. If  $3n$  is an odd number, which of the following is an even number?
- (A)  $3n - 2$   
(B)  $3n + 2$   
(C)  $3n - 1$   
(D)  $3n + 2n$

10. What is the least number of plums that can be shared equally among 6, 9 or 12 children?
- (A) 27  
 (B) 36  
 (C) 54  
 (D) 72

Item 11 refers to the Venn diagram below.

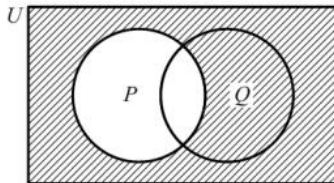

11. In the Venn diagram above, the shaded area represents
- (A)  $P'$   
 (B)  $(P \cup Q)'$   
 (C)  $Q \cup P'$   
 (D)  $Q \cap P'$
12. Which of the following sets is equivalent to  $\{a, b, c, d\}$ ?
- (A)  $\{4\}$   
 (B)  $\{a, b, c\}$   
 (C)  $\{p, q, r, s\}$   
 (D)  $\{1, 2, 3, 4, 5\}$

Item 13 refers to the Venn diagram below.

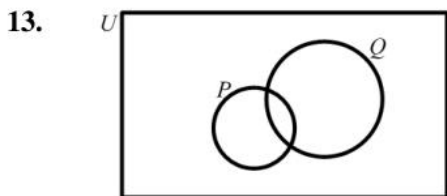

In the Venn diagram,  $n(P) = 5$ ,  $n(Q) = 9$  and  $n(P \cup Q) = 10$ . What is  $n(P \cap Q)$ ?

- (A) 4  
 (B) 6  
 (C) 14  
 (D) 24

Item 14 refers to the Venn diagram below.

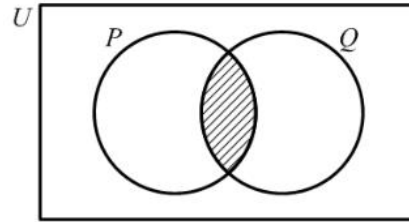

14. In the Venn diagram, if  $P = \{\text{Factors of 6}\}$  and  $Q = \{\text{Factors of 4}\}$ , then the shaded region represents
- (A)  $\{\}$   
 (B)  $\{1, 2\}$   
 (C)  $\{4, 6, 8, \dots\}$   
 (D)  $\{12, 24, 36, \dots\}$
15. The simple interest on \$400 at 5% per annum for 2 years is given by
- (A)  $\$ \frac{400 \times 5 \times 2}{100}$   
 (B)  $\$ \frac{400 \times 5}{2 \times 100}$   
 (C)  $\$ \frac{400 \times 2}{5 \times 100}$   
 (D)  $\$ \frac{400 \times 100}{2 \times 5}$

16. If  $p$  sweets cost  $q$  cents, then the cost of one sweet is
- (A)  $pq$  cents  
 (B)  $(q - p)$  cents  
 (C)  $\frac{p}{q}$  cents  
 (D)  $\frac{q}{p}$  cents

17. During a sale, a shop allows 20% discount off the marked price of clothing. What will a customer pay for a dress with a marked price of \$30 ?
- (A) \$10  
(B) \$20  
(C) \$24  
(D) \$30
18. Tom bought a pen for \$60 and sold it to gain 20% on his cost price. How much money did he gain?
- (A) \$12  
(B) \$40  
(C) \$72  
(D) \$80
19. Susan bought a calculator for \$120. She had to pay a sales tax of 10% on the price. How much change would she receive from \$140 ?
- (A) \$8.00  
(B) \$12.00  
(C) \$28.00  
(D) \$32.00
20. Mary invested \$200 for 3 years at 5% per annum. John invested \$300 at the same rate. If they both received the same amount of money in interest, for how many years did John invest his money?
- (A)  $1\frac{1}{2}$   
(B) 2  
(C) 3  
(D) 10
21. A company employs 12 gardeners at \$26 per day, and 8 clerks at \$17 per day. What is the mean daily wage, in dollars, of the 20 employees?
- (A) \$20.00  
(B) \$21.50  
(C) \$22.40  
(D) \$31.50
22. If the simple interest on \$800 for 3 years is \$54. What is the rate of interest per annum?
- (A)  $\frac{4}{9}\%$   
(B)  $2\frac{1}{4}\%$   
(C) 5%  
(D) 44%
23.  $-2(x-4) =$
- (A)  $-2x+8$   
(B)  $-2x+4$   
(C)  $2x-4$   
(D)  $-2x-8$
24.  $(8a)^2 =$
- (A)  $16a$   
(B)  $64a$   
(C)  $16a^2$   
(D)  $64a^2$
25. Given that  $a\Delta b = 2a - 3b$  then  $2\Delta(-3) =$
- (A) -7  
(B) -5  
(C) 3  
(D) 13

26. If,  $20a - 16 = 12 - 3a$  then  $a =$

- (A)  $\frac{5}{8}$   
 (B)  $\frac{21}{16}$   
 (C)  $\frac{13}{8}$   
 (D)  $\frac{5}{2}$

27. If  $P = \frac{m^2}{2-m}$ , when  $m = -3$ , then  $P =$

- (A)  $-6$   
 (B)  $\frac{-6}{5}$   
 (C)  $\frac{9}{5}$   
 (D)  $9$

28.  $2(a^2b)^3 =$

- (A)  $2a^5b^3$   
 (B)  $2a^6b^3$   
 (C)  $6a^2b$   
 (D)  $8a^6b^3$

29. For all of  $a$  and  $b$ ,  $3a(a + 2b) - b(2a - 3b) =$

- (A)  $3a^2 - ab + 3b^2$   
 (B)  $3a^2 + 4ab + 3b^2$   
 (C)  $3a^2 + 4ab - 3b^2$   
 (D)  $3a^2 + 8ab - 3b^2$

30. Which of the following represents the statement "The difference of two square numbers is positive"?

- (A)  $x^2 - y^2 > 0$   
 (B)  $2x - 2y > 0$   
 (C)  $(y - x)^2 > 0$   
 (D)  $2(y - x) > 0$

31. John has  $x$  marbles and Max has twice as many. Max gives John 5 of his marbles. How many marbles does Max now have?

- (A)  $x + 5$   
 (B)  $x - 5$   
 (C)  $2x + 5$   
 (D)  $2x - 5$

32. The volume of a cube with edges 10 cm is

- (A)  $30 \text{ cm}^3$   
 (B)  $100 \text{ cm}^3$   
 (C)  $300 \text{ cm}^3$   
 (D)  $1000 \text{ cm}^3$

33. How many kilograms are there in one tonne?

- (A) 10  
 (B) 100  
 (C) 1000  
 (D) 10000

34. On leaving Trinidad, the time on a pilot's watch was 23:00 hrs. When he arrived at his destination in the same time zone, on the following day, his watch showed 03:00 hrs. How many hours did the flight take?

- (A) 4  
 (B) 20  
 (C) 26  
 (D) 52

35. The circumference of a circle is 132 cm. Given that  $\pi = \frac{22}{7}$ , the radius of the circle in centimeters, is

- (A) 42  
 (B) 21  
 (C)  $\sqrt{42}$   
 (D)  $\sqrt{21}$

Item 36 refers to the diagram below.

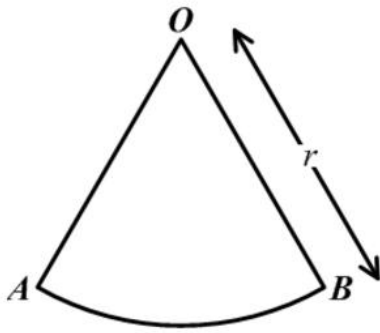

36.  $AOB$  is a sector of a circle such that angle  $AOB = 60^\circ$  and  $OB$  is  $r$  units long. The area of  $AOB$  is

- (A)  $\frac{1}{3}\pi r$
- (B)  $\frac{1}{6}\pi r$
- (C)  $\frac{1}{3}\pi r^2$
- (D)  $\frac{1}{6}\pi r^2$

Item 37 refers to the diagrams below.

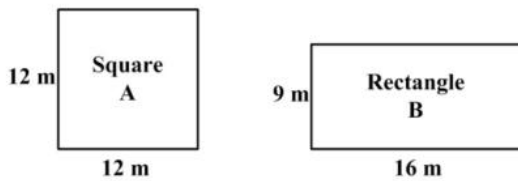

37. Which of the following statements is true about the perimeters of the figures A and B?

- (A) Perimeter of A = Perimeter of B
- (B) Perimeter of A > Perimeter of B
- (C) Perimeter of A  $\geq$  Perimeter of B
- (D) Perimeter of A < Perimeter of B

38. The area of a rectangle is  $53.6 \text{ cm}^2$ . If the length is multiplied by four and the width is halved, the area would then be

- (A)  $26.8 \text{ cm}^2$
- (B)  $53.6 \text{ cm}^2$
- (C)  $107.2 \text{ cm}^2$
- (D)  $214.4 \text{ cm}^2$

Item 39 refers to the diagram below.

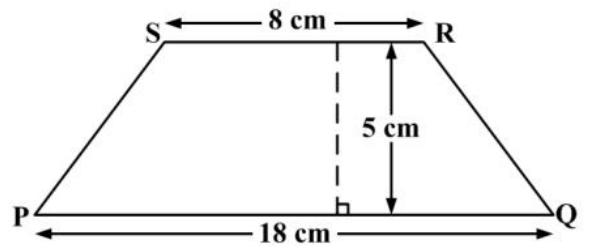

39. The area of the trapezium above is

- (A)  $45 \text{ cm}^2$
- (B)  $65 \text{ cm}^2$
- (C)  $90 \text{ cm}^2$
- (D)  $130 \text{ cm}^2$

40. The marks obtained by ten students in a test marked out of 25 were:

14, 22, 15, 19, 19, 16, 24, 13, 20, 19

The range of the marks was

- (A) 11
- (B) 13
- (C) 18
- (D) 19

Item 41 refers to the following table.

10	15	4	7
8	8	1	4

41. The median of the eight scores in the table is

- (A) 4
- (B) 7.25
- (C) 7.50
- (D) 8

42. A bag contains 2 red ,4 yellow and 6 blue balls. The probability of drawing a **blue** ball from the bag at random is

- (A)  $\frac{1}{6}$
- (B)  $\frac{1}{3}$
- (C)  $\frac{1}{2}$
- (D)  $\frac{6}{11}$

Item 43 refers to the following table.

Length of Leaf (cm)	10-14	15-19	20-24	25-29
Frequency	3	8	12	7

43. The lengths of 30 cabbage leaves were measured, to the nearest cm, and the information grouped as shown in the table above.

The class boundaries are

- (A) 3,8,12,7
- (B) 5,5,5,5
- (C) 10,14,15,19,20,24,25,29
- (D) 9.5,14.5,19.5,24.5,29.5

Item 44 refers to the following pie-chart. O is the centre of the circle and AOC is the diameter

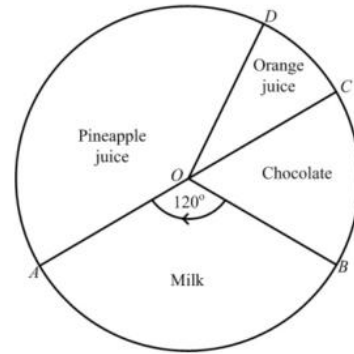

44. The pie chart shows the preference in drinks of a group of students. If 12 students prefer chocolate, then the TOTAL number of students is

- (A) 48
- (B) 72
- (C) 180
- (D) 360

45. If the mean of four numbers 4, 8, x and 12 is 10, then x is

- (A) 4
- (B) 10
- (C) 12
- (D) 16

46. Which of the following represents the equation of a straight line?

- (A)  $y = \frac{4}{x}$
- (B)  $y = 2x + 3$
- (C)  $y = x^2 - 4$
- (D)  $y = x^2 + 2x - 5$

47. If  $f(x) = x^2 - x - 1$ , then  $f(-5) =$

- (A) -31
- (B) 24
- (C) 29
- (D) 31

Item 48 refers to the diagram below.

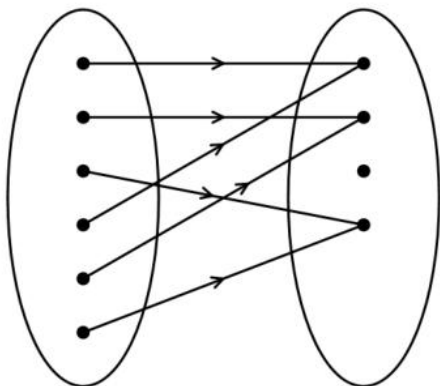

48. The relationship that BEST describes the mapping in the above diagram is

- (A) one-to-one
- (B) one-to-many
- (C) many-to-one
- (D) many-to-many

49. Which of the following represents the graph of a function?

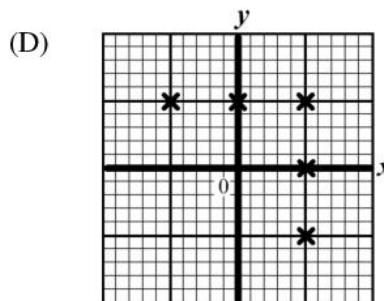
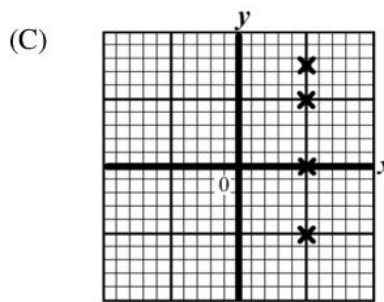
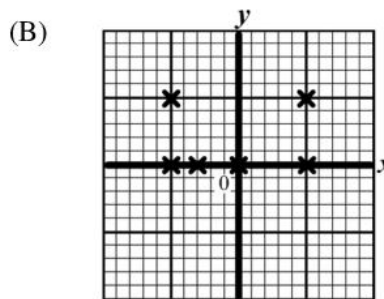
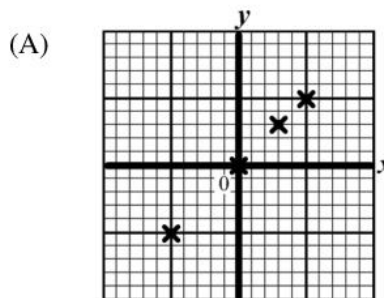

50. Which of the following sets is represented by the relation  $f(x) = x^2 + 3$ ?
- (A)  $\{(0, 3), (1, 4), (2, 7), (3, 12)\}$
  - (B)  $\{(0, 3), (1, 5), (2, 7), (3, 9)\}$
  - (C)  $\{(0, 3), (1, 4), (2, 5), (3, 6)\}$
  - (D)  $\{(0, 3), (1, 1), (2, 4), (3, 9)\}$

51. The range of  $f : x \rightarrow x^3$  for the domain  $\{-2, -1, 0, 1, 2\}$  is
- (A)  $\{0, 1, 8\}$
  - (B)  $\{-2, -1, 0, 1, 2\}$
  - (C)  $\{-6, -3, 0, 3, 6\}$
  - (D)  $\{-8, -1, 0, 1, 8\}$

52. A boat was travelling on a bearing of  $270^\circ$ . In what direction was it travelling?
- (A) West
  - (B) East
  - (C) North
  - (D) South

Item 53 refers to the following diagram.

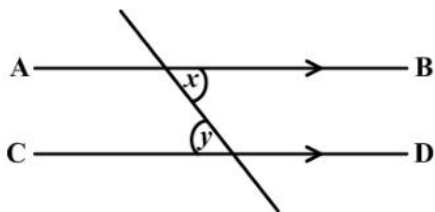

53. In the diagram,  $AB$  and  $CD$  are parallel. Which of the following BEST describes the relation between  $x$  and  $y$ ?
- (A)  $x + y < 2x$
  - (B)  $x = y$
  - (C)  $x + y > 2x$
  - (D)  $x > y$

Item 54 refers to the following diagram.

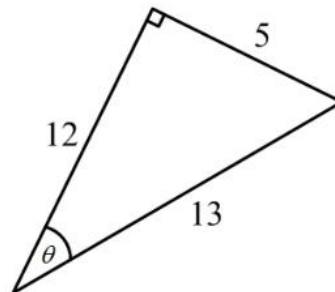

54. In the right-angled triangle above,  $\tan \theta$  is
- (A)  $\frac{5}{13}$
  - (B)  $\frac{5}{12}$
  - (C)  $\frac{12}{5}$
  - (D)  $\frac{13}{5}$

55. The image of a point  $P(-2, 3)$  under a translation  $\begin{pmatrix} 3 \\ 4 \end{pmatrix}$  is
- (A)  $(-6, 12)$
  - (B)  $(-5, -1)$
  - (C)  $(5, 1)$
  - (D)  $(1, 7)$

**Item 56** refers to the following diagram

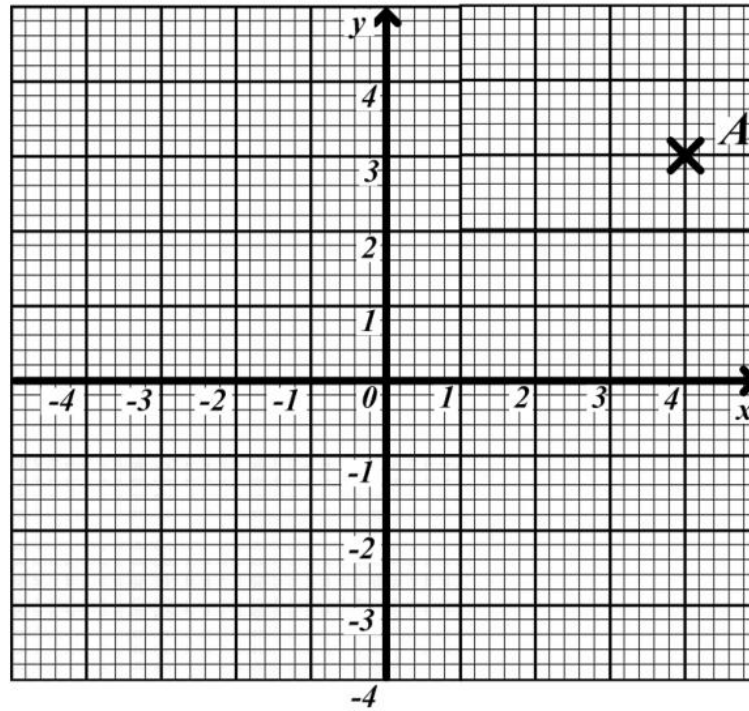

56. The point  $A$  is shown on the diagram above. What are the co-ordinates of the reflection of  $A$  in the  $y$ -axis?

- (A)  $(-4, 3)$
- (B)  $(4, -3)$
- (C)  $(3, -4)$
- (D)  $(-3, 4)$

57. A ship sailed 8 km due east from  $A$  to  $B$ . It then sailed 6 km due north to  $C$ . Which diagram below BEST represents the path of the ship?

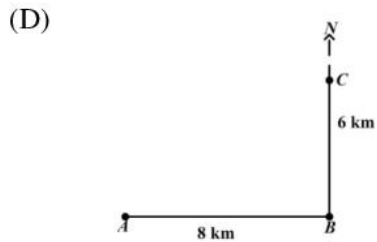
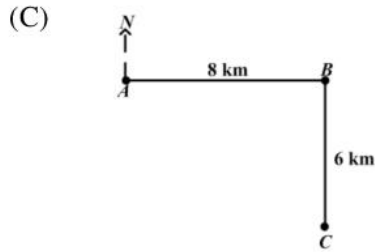
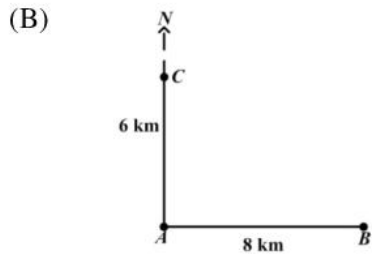
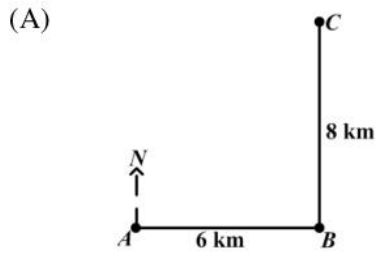

Item 58 refers to the diagram below.

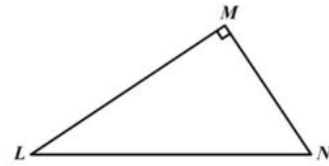

58. The triangle  $LMN$  is rotated in a clockwise direction about  $L$  through an angle of  $90^\circ$ . What is its image?

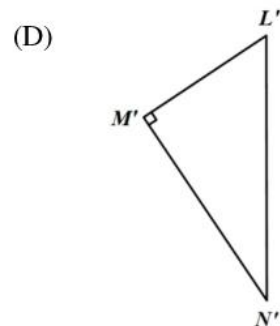
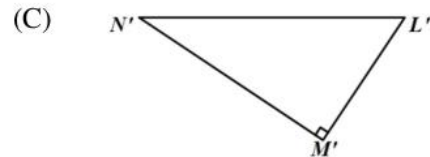
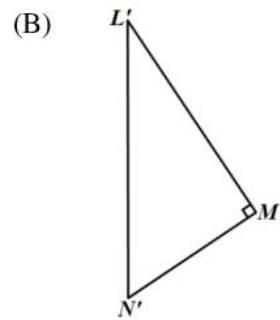
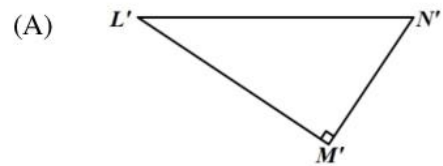

Item 59 refers to the following diagram.

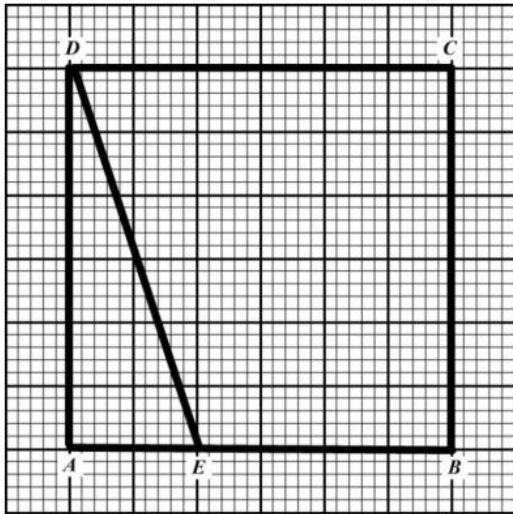

59. How many triangles congruent to  $\triangle ADE$  would be needed to cover the rectangle  $ABCD$  entirely?

- (A) 8
- (B) 6
- (C) 4
- (D) 2

Item 60 refers to the diagram of a building below.

A boy stands 12 metres from the foot of the building and observes the angle of elevation of the top of the building.

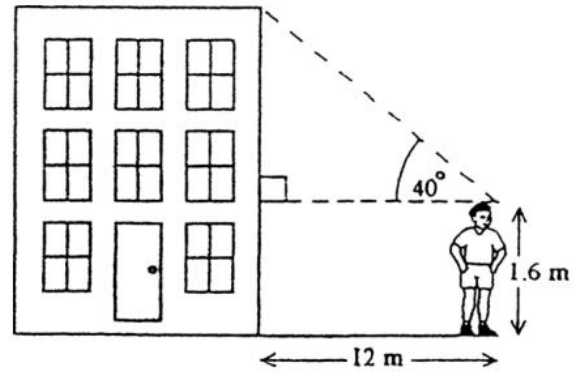

60. The height of the building is approximately

- (A)  $12 \tan 40^\circ$
- (B)  $1.6 + 12 \sin 40^\circ$
- (C)  $1.6 + 12 \cos 40^\circ$
- (D)  $1.6 + 12 \tan 40^\circ$

**IF YOU FINISH BEFORE TIME IS CALLED, CHECK YOUR WORK ON THIS TEST.**



↑ AFFIX SEAL HERE ↑

**CANDIDATE –PLEASE NOTE!**

You must sign below and return this booklet with the Answer Sheet. Failure to do so may result in disqualification.

\_\_\_\_\_  
SignatureTEST CODE **01234010**

JANUARY 2010

**FORM TP 2007104**

**CARIBBEAN EXAMINATIONS COUNCIL**  
**SECONDARY EDUCATION CERTIFICATE**  
**EXAMINATION**  
**MATHEMATICS**  
**Paper 01 – General Proficiency**  
*90 minutes*

05 JANUARY 2010 (p.m.)

**READ THE FOLLOWING DIRECTIONS CAREFULLY**

1. In addition to this test booklet, you should have an answer sheet.
2. Calculators and mathematical tables may NOT be used for this paper.
3. **A list of formulae is provided on page 2 of this booklet.**
4. This test consists of 60 items. You will have 90 minutes to answer them.
5. Each item in this test has four suggested answers, lettered (A), (B), (C), (D). Read each item you are about to answer, and decide which choice is best.
6. On your answer sheet, find the number which corresponds to your item and blacken the space having the same letter as the answer you have chosen. Look at the sample item below.

Sample Item

$2a + 6a =$

- (A)  $8a$   
 (B)  $8a^2$   
 (C)  $12a$   
 (D)  $12a^2$

Sample Answer

The best answer to this item is “8a”, so answer space (A) has been blackened.

7. If you want to change your answer, erase your old answer completely and fill in your new choice.
8. When you are told to begin, turn the page and work as quickly and as carefully as you can. If you cannot Answer an item, omit it and go on to the next one. You can return later to the item omitted. Your score will be the total number of correct answers.
9. You may do any rough work in the booklet.
10. Do not be concerned that the answer sheet provides spaces for more answers than there are items in this test.

**DO NOT TURN THIS PAGE UNTIL YOU ARE TOLD TO DO SO.**

Copyright © 2009 Caribbean Examinations Council ®.

**LIST OF FORMULAE**

Volume of a prism  $V = Ah$  where  $A$  is the area of a cross-section and  $h$  is the perpendicular length.

Volume of a cylinder  $V = \pi r^2 h$  where  $r$  is the radius of the base and  $h$  is the perpendicular height.

Volume of a right pyramid  $V = \frac{1}{3}Ah$  where  $A$  is the area of the base and  $h$  is the perpendicular height.

Circumference  $C = 2\pi r$  where  $r$  is the radius of the circle.

Area of a circle  $A = \pi r^2$  where  $r$  is the radius of the circle.

Area of Trapezium  $A = \frac{1}{2}(a + b)h$  where  $a$  and  $b$  are the lengths of the parallel sides and  $h$  is the perpendicular distance between the parallel sides.

Roots of quadratic equations If  $ax^2 + bx + c = 0$ ,  
 then  $x = \frac{-b \pm \sqrt{b^2 - 4ac}}{2a}$

Trigonometric ratios

$$\sin \theta = \frac{\text{opposite side}}{\text{hypotenuse}}$$

$$\cos \theta = \frac{\text{adjacent side}}{\text{hypotenuse}}$$

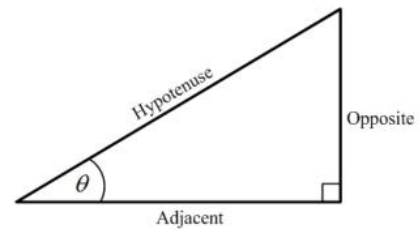
$$\tan \theta = \frac{\text{opposite side}}{\text{adjacent side}}$$

Area of triangle Area of  $\Delta = \frac{1}{2}bh$  where  $b$  is the length of the base and  $h$  is the perpendicular height

$$\text{Area of } \Delta ABC = \frac{1}{2}ab \sin C$$

$$\text{Area of } \Delta ABC = \sqrt{s(s-a)(s-b)(s-c)}$$

$$\text{where } s = \frac{a+b+c}{2}$$

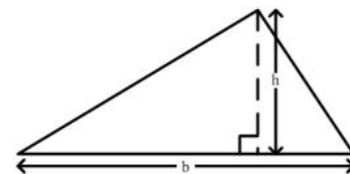

Sine rule  $\frac{a}{\sin A} = \frac{b}{\sin B} = \frac{c}{\sin C}$

Cosine rule  $a^2 = b^2 + c^2 - 2bc \cos A$

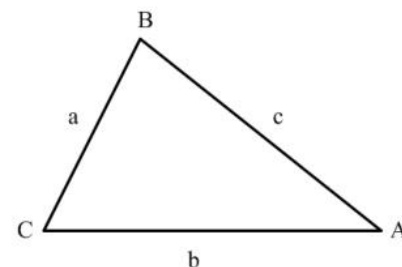

1. The number 0.0346 written in standard form is
- (A)  $3.46 \times 10^{-2}$   
(B)  $3.46 \times 10^{-1}$   
(C)  $3.46 \times 10$   
(D)  $3.46 \times 10^2$
2. The value of  $0.386 \times 0.06$  is
- (A) 0.02316  
(B) 0.2316  
(C) 2.316  
(D) 23.16
3. The number 3.14063 written to 3 decimal places is
- (A) 3.140  
(B) 3.141  
(C) 3.146  
(D) 3.150
4. If 60% of a number is 90, what is the number?
- (A) 30  
(B) 54  
(C) 150  
(D) 180
5. What number when added to  $1\frac{1}{3}$  gives 2?
- (A)  $\frac{1}{3}$   
(B)  $\frac{2}{3}$   
(C)  $1\frac{2}{3}$   
(D)  $3\frac{1}{3}$
6. John, Peter and Mary shared a sum of money in the ratio 2:4:9. John and Peter together received \$360. How much money was shared altogether?
- (A) \$480  
(B) \$540  
(C) \$600  
(D) \$900
7. The value of the digit 2 in 425.3 is
- (A) 2 tens  
(B) 2 ones  
(C) 2 tenths  
(D) 2 hundreds
8.  $25 \times 130$  is the same as
- (A)  $(25 \times 100) + 30$   
(B)  $(25 + 30) \times 100$   
(C)  $(25 \times 30) + (25 \times 100)$   
(D)  $(100 \times 30) + (100 \times 25)$
9. The largest prime number that is less than 100 is
- (A) 91  
(B) 93  
(C) 97  
(D) 99
10. What is the LEAST number of plums that can be shared equally among either 6, 9 or 12 children?
- (A) 27  
(B) 36  
(C) 54  
(D) 72

11. Of a class of 32 students, 17 study Music and 20 study Art. What is the LEAST number of students who are studying BOTH Music and Art?
- (A) 3  
(B) 5  
(C) 12  
(D) 15
12. Which of the following sets is equivalent to  $\{a, b, c, d\}$ ?
- (A)  $\{4\}$   
(B)  $\{a, b, c\}$   
(C)  $\{p, q, r, s\}$   
(D)  $\{1, 2, 3, 4, 5\}$
- Item 13 refers to the following information.
13.  $P = \{\text{prime numbers}\}$   
 $Q = \{\text{odd numbers}\}$   
 $R = \{\text{even numbers}\}$
- Which of the following sets is empty?
- (A)  $Q \cap R$   
(B)  $P \cap R$   
(C)  $P \cap Q$   
(D)  $P \cup Q$
14. If  $U = \{1, 3, 5, 6, 8\}$  and  $A = \{3, 6\}$ , then the number of elements in  $A'$  is
- (A) 2  
(B) 3  
(C) 4  
(D) 8
15.  $3\frac{1}{4}\%$  of \$500 is
- (A) \$ 1.62  
(B) \$15.52  
(C) \$16.00  
(D) \$16.25
16. A dress which costs \$180 is being sold at a discount of 10%. The amount of the discount is
- (A) \$ 1.80  
(B) \$ 10.00  
(C) \$ 18.00  
(D) \$170.00
17. If \$7000 is borrowed at the rate of 5% per annum for 3 years, the simple interest is
- (A) \$ 105  
(B) \$ 210  
(C) \$ 370  
(D) \$1 050
18. The exchange rate for one United States dollar ( $US\$1.00$ ) is two dollars and seventy cents in Eastern Caribbean currency ( $EC\$2.70$ ). What is the value of  $US\$4.50$  in  $EC$  currency?
- (A) \$ 1.67  
(B) \$ 6.00  
(C) \$ 7.20  
(D) \$12.15

19. How much does a customer pay for an article marked at \$50.00 if a sales tax of 6% is charged?

- (A) \$44.00
- (B) \$47.00
- (C) \$53.00
- (D) \$56.00

20. A salesman sells a car for \$11 000. If he is paid a commission of 4.5% for the first \$10 000 and 7.5% on the remainder, then the commission he receives is

- (A) \$ 495
- (B) \$ 525
- (C) \$ 825
- (D) \$1 320

21. A company employs 12 gardeners at \$26 per day, and 8 clerks at \$17 per day. What is the mean daily wage of the 20 employees?

- (A) \$20.00
- (B) \$21.50
- (C) \$22.40
- (D) \$31.50

22. If the simple interest on \$800 for 3 years is \$54, what is the rate of interest per annum?

- (A)  $\frac{4}{9}\%$
- (B)  $2\frac{1}{4}\%$
- (C) 5%
- (D) 44%

23.  $2a^3 + (2a)^3 =$

- (A)  $10a^3$
- (B)  $10a^6$
- (C)  $16a^3$
- (D)  $16a^6$

Item 24 refers to the information below

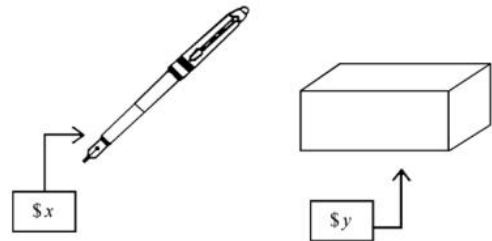

24. The total cost of 3 pens and 2 boxes is

- (A)  $5xy$
- (B)  $5(x + y)$
- (C)  $2x + 3y$
- (D)  $3x + 2y$

25. Given that  $2x + 3 \geq 9$ , the range of values of  $x$  is

- (A)  $x \geq 3$
- (B)  $x > 3$
- (C)  $x \geq 6$
- (D)  $x > 6$

26. If  $a * b = \frac{b}{a} - 1$ , then  $7 * 28 =$

- (A)  $-\frac{3}{4}$
- (B)  $\frac{1}{4}$
- (C) 3
- (D) 4

27. Althea saves  $\$x$  each month; but in June she saved  $\$4$  more than twice her usual amount. In June Althea saved

(A)  $\$4x$   
 (B)  $\$6x$   
 (C)  $\$(x+4)$   
 (D)  $\$(2x+4)$

28.  $5(x+y) - 3(x-y) =$

(A)  $2x$   
 (B)  $2x + 2y$   
 (C)  $2x + 8y$   
 (D)  $8x + 8y$

29. If  $x$  is an integer which satisfies the inequalities  $4 < x - 2 < 8$  then the SMALLEST possible value of  $x$  is

(A) 7  
 (B) 6  
 (C) 5  
 (D) 4

30. Think of a number. Subtract 8 from it. Multiply the difference by 3. The result is 21. What is the original number

(A) 1  
 (B) 3  
 (C) 10  
 (D) 15

31. For all  $a$  and  $b$ ,  $3a(a+2b) - b(2a-3b) \equiv$

(A)  $3a^2 + 4ab + 3b^2$   
 (B)  $3a^2 - ab + 3b^2$   
 (C)  $3a^2 + 4ab - 3b^2$   
 (D)  $3a^2 + 8ab - 3b^2$

- Item 32 refers to the circle below, with centre O.

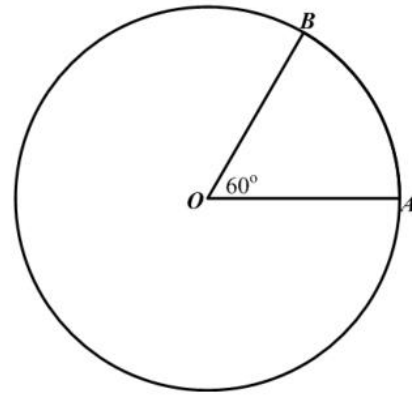

32. The circumference of the circle is 20 cm. The length of the minor arc  $AB$ , in centimeters is

(A)  $\frac{1}{60} \times 20$   
 (B)  $\frac{60}{360} \times 20$   
 (C)  $\left(\frac{360-60}{360}\right) \times 20$   
 (D)  $60 \times 20$

33. If it took a speed-boat 9 hours to travel a distance of 1080 km, what was its average speed?

(A) 12 km/h  
 (B) 102 km/h  
 (C) 120 km/h  
 (D) 1200 km/h

34. The volume of a cube whose edge is 6 cm long is

(A)  $18 \text{ cm}^3$   
 (B)  $36 \text{ cm}^3$   
 (C)  $72 \text{ cm}^3$   
 (D)  $216 \text{ cm}^3$

Item 35 refers to the trapezium below.

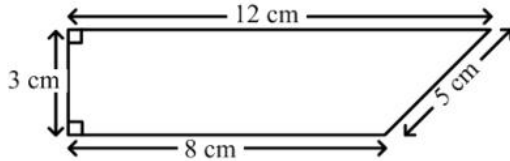

35. The area of the trapezium is
- (A)  $24 \text{ cm}^2$   
 (B)  $28 \text{ cm}^2$   
 (C)  $30 \text{ cm}^2$   
 (D)  $36 \text{ cm}^2$
36. The distance around the edge of a circular pond is 88 m. The radius, in metres, is
- (A)  $176\pi$   
 (B)  $88\pi$   
 (C)  $\frac{88}{\pi}$   
 (D)  $\frac{88}{2\pi}$

Item 37 refers to the following diagram

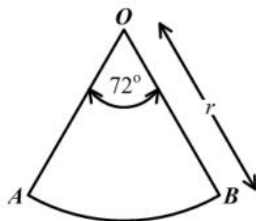

37.  $AOB$  is a sector of a circle such that angle  $AOB = 72^\circ$  and  $OB$  is  $r$  units long. The area of  $AOB$  is
- (A)  $\frac{1}{5}\pi r^2$   
 (B)  $\frac{2}{5}\pi r^2$   
 (C)  $\frac{1}{5}\pi r$   
 (D)  $\frac{2}{5}\pi r$

38. A man leaves home at 22:15 hrs and reaches his destination, in the same time zone, at 04:00 hrs on the following day. How many hours did the journey take?
- (A) 5  
 (B)  $5\frac{3}{4}$   
 (C) 6  
 (D)  $6\frac{1}{4}$

39. The area of a rectangle is  $53.6 \text{ cm}^2$ . If the length is multiplied by 4 and the width is divided by 2, the area would then be
- (A)  $107.2 \text{ cm}^2$   
 (B)  $53.6 \text{ cm}^2$   
 (C)  $26.8 \text{ cm}^2$   
 (D)  $13.4 \text{ cm}^2$

40. The median of the numbers: 1, 1, 5, 5, 6, 7, 7, 7, 7, 8 is
- (A) 5.4  
 (B) 6  
 (C) 6.5  
 (D) 7

Item 41 refers to the table below which shows the frequency of scores obtained by students in a test.

Scores	2	3	5	6	8	10
Students	7	4	6	3	5	2

41. The range of scores is
- (A) 2  
 (B) 7  
 (C) 8  
 (D) 10

Item 42 refers to the bar chart below which shows the ages of children who took part in a survey.

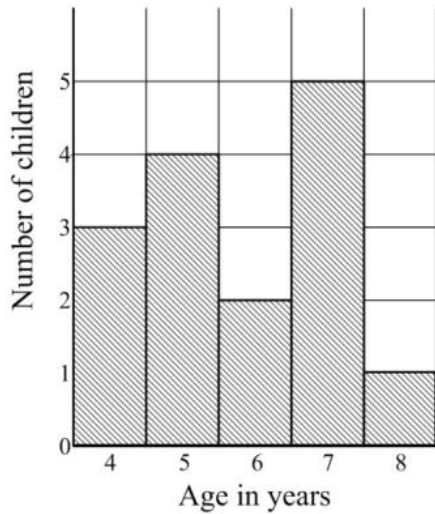

42. How many children took part in the survey?

- (A) 5
- (B) 15
- (C) 75
- (D) 87

43. If the mean of four numbers 4, 8,  $x$  and 12 is 10, then  $x$  is

- (A) 4
- (B) 10
- (C) 12
- (D) 16

44. A bag contains 2 red, 4 yellow and 6 blue balls. The probability of drawing a **blue** ball at random from the bag is

- (A)  $\frac{1}{6}$
- (B)  $\frac{1}{3}$
- (C)  $\frac{1}{2}$
- (D)  $\frac{6}{11}$

45. A bag contains 60 marbles of different colours. The probability of choosing a red marble is  $\frac{5}{12}$ . How many red marbles does the bag contain?

- (A) 25
- (B) 17
- (C) 12
- (D) 5

Item 46 refers to the diagram below.

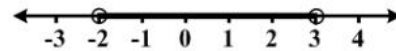

46. The graph of the inequality in the diagram above is defined by

- (A)  $-2 < x \leq 3$
- (B)  $-2 \leq x < 3$
- (C)  $-2 \leq x \leq 3$
- (D)  $-2 < x < 3$

Item 47 refers to the arrow diagram below

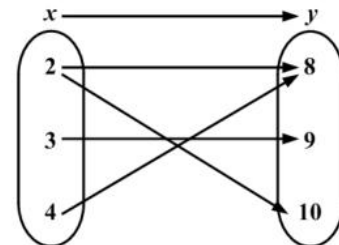

47. The arrow diagram above describes the relation

- (A)  $x$  is a factor of  $y$
- (B)  $x$  is less than  $y$
- (C)  $x$  is a multiple of  $y$
- (D)  $x$  is greater than  $y$

48. If  $h(x) = \frac{3x-2}{5}$ , then  $h(-6) =$

- (A)  $-4$   
 (B)  $\frac{-16}{5}$   
 (C)  $\frac{16}{5}$   
 (D)  $4$

49. Which of the following points lies on the line  $y = 2x - 3$ ?

- (A)  $(2, 3)$   
 (B)  $(-2, -1)$   
 (C)  $(4, 1)$   
 (D)  $(0, -3)$

**Item 50** refers to the arrow diagram below, which shows a function.

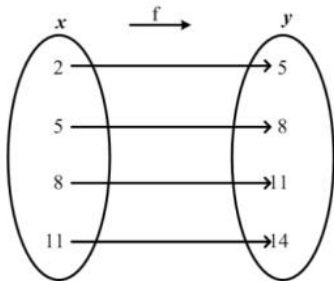

50. Which of the following best describes the function?

- (A)  $f(x) = x + 3$   
 (B)  $f(x) = y + 3$   
 (C)  $x = y + 3$   
 (D)  $y = x$

51. The range of  $f : x \rightarrow x^3$  for the domain  $\{-2, -1, 0, 1, 2\}$  is

- (A)  $\{0, 1, 8\}$   
 (B)  $\{-2, -1, 0, 1, 2\}$   
 (C)  $\{-6, -3, 0, 3, 6\}$   
 (D)  $\{-8, -1, 0, 1, 8\}$

**Item 52** refers to the right-angled triangle below.

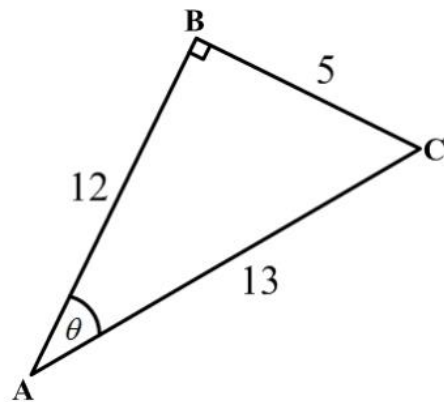

52. In the right-angled triangle,  $\tan \theta$  is

- (A)  $\frac{5}{13}$   
 (B)  $\frac{5}{12}$   
 (C)  $\frac{12}{5}$   
 (D)  $\frac{13}{5}$

Item 53 refers to the diagram below.

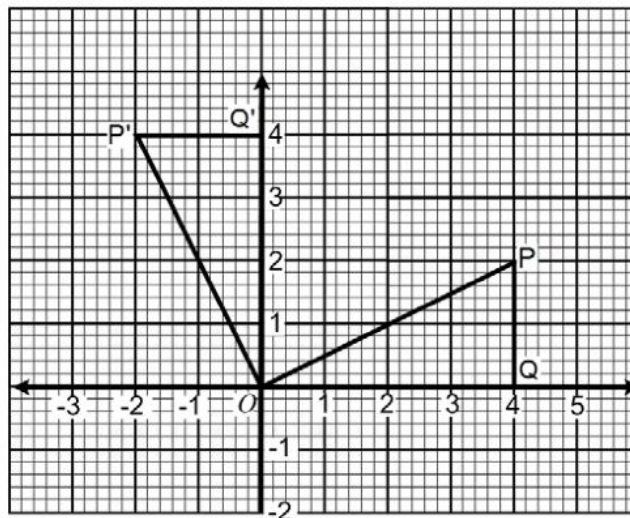

53. In the figure above,  $\Delta OPQ$  is mapped onto  $\Delta OP'Q'$ . What type of transformation has taken place?

- (A) Reflection
- (B) Enlargement
- (C) Translation
- (D) Rotation

Item 54 refers to the diagram below.

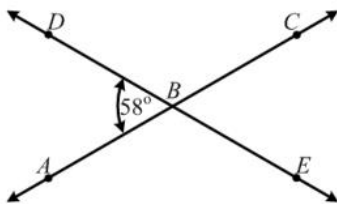

54. The measure of angle  $ABE$  is

- (A)  $58^{\circ}$
- (B)  $122^{\circ}$
- (C)  $142^{\circ}$
- (D)  $302^{\circ}$

55.

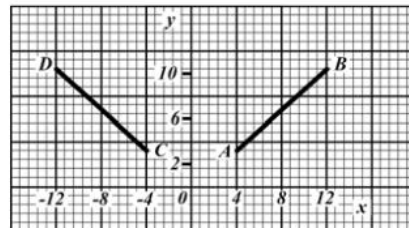

In the figure above, the line  $CD$  is the image of  $AB$  after

- (A) a rotation through  $90^{\circ}$  centre  $O$
- (B) a reflection in the  $y$ -axis
- (C) a translation by vector  $\begin{pmatrix} -4 \\ -8 \end{pmatrix}$
- (D) an enlargement of scale factor  $-1$

Item 56 refers to the diagram below.

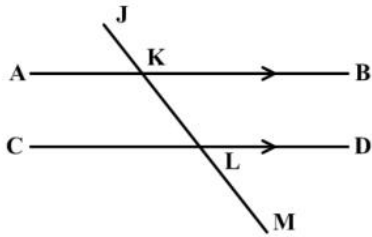

56. In the diagram above,  $AB$  is parallel to  $CD$ , and  $\angle JKB = 125^\circ$ .

The measure of angle  $MLD$  is

- (A)  $125^\circ$
- (B)  $90^\circ$
- (C)  $75^\circ$
- (D)  $55^\circ$

Item 57 refers to the diagram below.

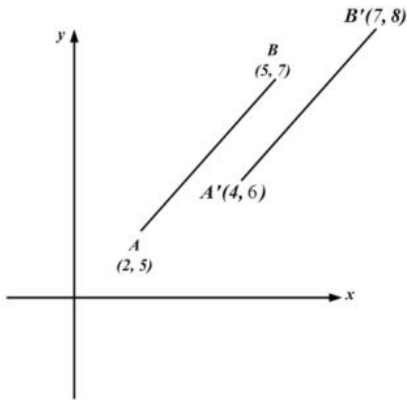

57. The translation by which  $AB$  is mapped to  $A'B'$  is represented by

- (A)  $\begin{pmatrix} 1 \\ 1 \end{pmatrix}$
- (B)  $\begin{pmatrix} 2 \\ 1 \end{pmatrix}$
- (C)  $\begin{pmatrix} 3 \\ 2 \end{pmatrix}$
- (D)  $\begin{pmatrix} 5 \\ 3 \end{pmatrix}$

58. A plane is heading in a direction of  $045^\circ$  and changes course in a clockwise direction to  $135^\circ$ . The angle through which the plane turns is

- (A)  $45^\circ$
- (B)  $90^\circ$
- (C)  $135^\circ$
- (D)  $270^\circ$

Item 59 refers to the diagram below

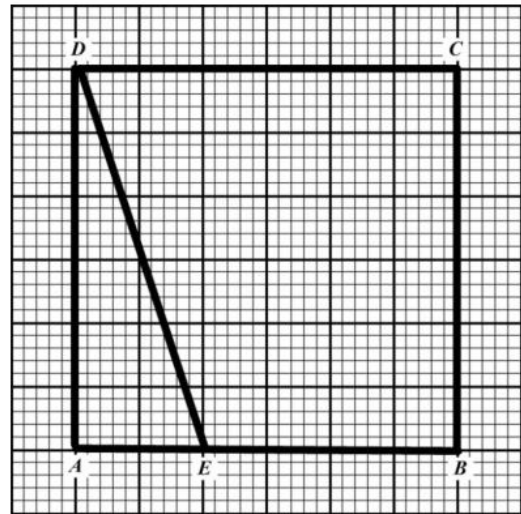

59. How many triangles congruent to  $\triangle ADE$  would be needed to cover the rectangle  $ABCD$  entirely?

- (A) 2
- (B) 4
- (C) 6
- (D) 8

60. In a triangle  $ABC$ , angle  $A = x^\circ$  and angle  $B = 2x^\circ$ . What is the size of angle  $C$ ?

- (A)  $(180 - 3x)^\circ$
- (B)  $60^\circ$
- (C)  $45^\circ$
- (D)  $\left(\frac{180}{3x}\right)^\circ$

**IF YOU FINISH BEFORE TIME IS CALLED, CHECK YOUR WORK ON THIS TEST.**



↑ AFFIX SEAL HERE ↑

**CANDIDATE –PLEASE NOTE!**

You must sign below and return this booklet with the Answer Sheet. Failure to do so may result in disqualification.

\_\_\_\_\_  
SignatureTEST CODE **01234010**

MAY/JUNE 2010

**FORM TP 2007104**

**CARIBBEAN EXAMINATIONS COUNCIL**  
**SECONDARY EDUCATION CERTIFICATE**  
**EXAMINATION**  
**MATHEMATICS**  
**Paper 01 – General Proficiency**  
*90 minutes*

19 MAY 2010 (p.m.)

**READ THE FOLLOWING DIRECTIONS CAREFULLY**

1. In addition to this test booklet, you should have an answer sheet.
2. Calculators and mathematical tables may NOT be used for this paper.
3. **A list of formulae is provided on page 2 of this booklet.**
4. This test consists of 60 items. You will have 90 minutes to answer them.
5. Each item in this test has four suggested answers, lettered (A), (B), (C), (D). Read each item you are about to answer, and decide which choice is best.
6. On your answer sheet, find the number which corresponds to your item and blacken the space having the same letter as the answer you have chosen. Look at the sample item below.

Sample Item

$2a + 6a =$

- (A)  $8a$   
 (B)  $8a^2$   
 (C)  $12a$   
 (D)  $12a^2$

Sample Answer

The best answer to this item is “ $8a$ ”, so answer space (A) has been blackened.

7. If you want to change your answer, erase your old answer completely and fill in your new choice.
8. When you are told to begin, turn the page and work as quickly and as carefully as you can. If you cannot Answer an item, omit it and go on to the next one. You can return later to the item omitted. Your score will be the total number of correct answers.
9. You may do any rough work in the booklet.
10. Do not be concerned that the answer sheet provides spaces for more answers than there are items in this test.

**DO NOT TURN THIS PAGE UNTIL YOU ARE TOLD TO DO SO.**

Copyright © 2009 Caribbean Examinations Council ®.

**LIST OF FORMULAE**

Volume of a prism  $V = Ah$  where  $A$  is the area of a cross-section and  $h$  is the perpendicular length.

Volume of a cylinder  $V = \pi r^2 h$  where  $r$  is the radius of the base and  $h$  is the perpendicular height.

Volume of a right pyramid  $V = \frac{1}{3}Ah$  where  $A$  is the area of the base and  $h$  is the perpendicular height.

Circumference  $C = 2\pi r$  where  $r$  is the radius of the circle.

Area of a circle  $A = \pi r^2$  where  $r$  is the radius of the circle.

Area of Trapezium  $A = \frac{1}{2}(a + b)h$  where  $a$  and  $b$  are the lengths of the parallel sides and  $h$  is the perpendicular distance between the parallel sides.

Roots of quadratic equations If  $ax^2 + bx + c = 0$ ,  
 then  $x = \frac{-b \pm \sqrt{b^2 - 4ac}}{2a}$

Trigonometric ratios

$$\sin \theta = \frac{\text{opposite side}}{\text{hypotenuse}}$$

$$\cos \theta = \frac{\text{adjacent side}}{\text{hypotenuse}}$$

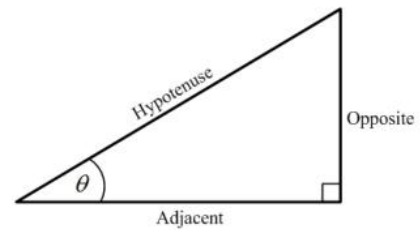
$$\tan \theta = \frac{\text{opposite side}}{\text{adjacent side}}$$

Area of triangle Area of  $\Delta = \frac{1}{2}bh$  where  $b$  is the length of the base and  $h$  is the perpendicular height

$$\text{Area of } \Delta ABC = \frac{1}{2}ab \sin C$$

$$\text{Area of } \Delta ABC = \sqrt{s(s-a)(s-b)(s-c)}$$

$$\text{where } s = \frac{a+b+c}{2}$$

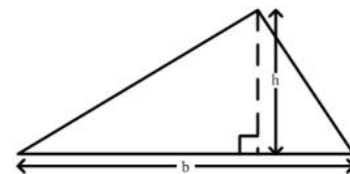

Sine rule  $\frac{a}{\sin A} = \frac{b}{\sin B} = \frac{c}{\sin C}$

Cosine rule  $a^2 = b^2 + c^2 - 2bc \cos A$

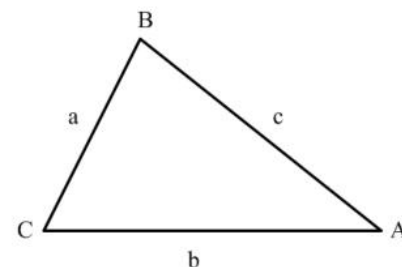

1. The number 3.14063 written correct to 3 decimal places is
- (A) 3.140  
(B) 3.141  
(C) 3.146  
(D) 3.150
2.  $(-3)^2 + (-2)^2 =$
- (A) -13  
(B) -10  
(C) 13  
(D) 25
3. In scientific notation, 170.04 is written as
- (A)  $0.17004 \times 10^3$   
(B)  $1.7004 \times 10^2$   
(C)  $17.004 \times 10^1$   
(D)  $1.7004 \times 10^{-2}$
4.  $0.386 \times 0.06 =$
- (A) 0.02316  
(B) 0.2316  
(C) 2.316  
(D) 23.16
5. What number when added to  $1\frac{1}{3}$  gives 2?
- (A)  $\frac{1}{3}$   
(B)  $\frac{2}{3}$   
(C) 1  
(D) 3
6. The EXACT value of  $\frac{37.26 \div 1.8}{1000}$  is
- (A) 0.207  
(B) 0.0207  
(C) 20.7000  
(D) 20700
7. The H.C.F. of 12, 15 and 60 is
- (A) 3  
(B) 5  
(C) 12  
(D) 60
8. The number 301 can be written as
- (A)  $3 \times 10^3 + 1 \times 10$   
(B)  $3 \times 10^2 + 1 \times 10$   
(C)  $3 \times 10^3 + 1$   
(D)  $3 \times 10^2 + 1$
9. If  $3n$  is an odd number, which of the following is an even number?
- (A)  $3n - 1$   
(B)  $3n - 2$   
(C)  $3n + 2$   
(D)  $3n + 2n$
10.  $25 \times 130$  is the same as
- (A)  $(25 \times 100) + 30$   
(B)  $(25 + 30) \times 100$   
(C)  $(25 \times 30) + (25 \times 100)$   
(D)  $(100 \times 30) + (100 \times 25)$

Item 11 refers to the Venn diagram below.

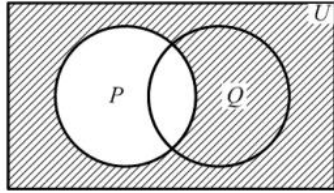

11. In the Venn diagram above, the shaded area represents
- (A)  $P'$
  - (B)  $(P \cup Q)'$
  - (C)  $Q \cap P'$
  - (D)  $Q \cup P'$
12. In a class of 32 students, 17 study Music and 20 study Art. What is the LEAST number of students who are studying BOTH Music and Art?
- (A) 3
  - (B) 5
  - (C) 12
  - (D) 15
13. If  $P = \{a, b, c\}$  then the number of subsets of  $P$  is
- (A) 8
  - (B) 6
  - (C) 4
  - (D) 3

Item 14 refers to the Venn diagram below.

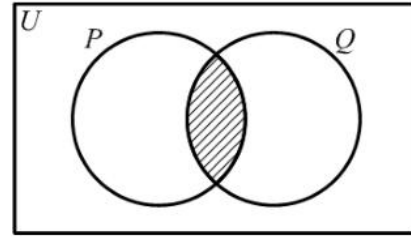

14. If  $P = \{\text{Factors of 6}\}$  and  $Q = \{\text{Factors of 4}\}$ , then the shaded region represents
- (A)  $\{ \}$
  - (B)  $\{1, 2\}$
  - (C)  $\{4, 6, 8, \dots\}$
  - (D)  $\{12, 24, 36, \dots\}$
15. If TT\$6.00 is equivalent to US\$1.00, then TT\$15.00 in U.S. dollars is
- (A) \$0.25
  - (B) \$0.40
  - (C) \$2.50
  - (D) \$4.00
16.  $3\frac{1}{4}\%$  of \$500 is
- (A) \$ 1.62
  - (B) \$15.52
  - (C) \$16.00
  - (D) \$16.25
17. If  $p$  sweets cost  $q$  cents, then the cost of one sweet is
- (A)  $\frac{q}{p}$  cents
  - (B)  $pq$  cents
  - (C)  $\frac{p}{q}$  cents
  - (D)  $(q - p)$  cents

18. A salesman is paid 5% of his sales as commission. His sales for last month were \$2020. How much commission was he paid?

(A) \$ 11.00  
 (B) \$ 20.20  
 (C) \$101.00  
 (D) \$110.00

19. How much does a customer pay for an article marked at \$50.00 if a sales tax of 6% is charged?

(A) \$56.00  
 (B) \$53.00  
 (C) \$47.00  
 (D) \$44.00

20. A table is sold on hire purchase. The sale price consists of a deposit of \$306 and six monthly installments of \$60 each. How much does a customer pay for the table?

(A) \$360  
 (B) \$366  
 (C) \$666  
 (D) \$966

21. A loan of \$8000 was repaid in 2 years in monthly payments of \$400.00. The interest on the loan, as a percentage, was

(A) 5%  
 (B) 8%  
 (C) 16%  
 (D) 20%

22. A man pays 60 cents for every 200 m<sup>3</sup> of gas used, plus a fixed charge of \$13.75. How much does he pay when he uses 55000 m<sup>3</sup> of gas?

(A) \$178.75  
 (B) \$175.25  
 (C) \$165.00  
 (D) \$151.25

23.  $(8a)^2 =$

(A)  $16a$   
 (B)  $64a$   
 (C)  $16a^2$   
 (D)  $64a^2$

Item 24 refers to the expansion below

$$(x+a)(x+b) = x^2 + (a+b)x + ab$$

24. The middle term in the expansion of  $(x+3)(x-1)$  is

(A) 2  
 (B) 3  
 (C)  $2x$   
 (D)  $4x$

25.  $5(x+y) - 3(x-y) =$

(A)  $2x$   
 (B)  $2x + 2y$   
 (C)  $2x + 8y$   
 (D)  $8x + 8y$

26.  $\frac{4x}{7y} + \frac{3x}{5y}$  may be written as

(A)  $\frac{41x}{35y}$   
 (B)  $\frac{41x^2}{35y}$   
 (C)  $\frac{41xy}{35y}$   
 (D)  $\frac{20x + 21y}{35y}$

27. If  $a * b = \frac{b}{a} - 1$ , then  $7 * 28 =$

- (A)  $-\frac{3}{4}$   
 (B)  $\frac{1}{4}$   
 (C) 3  
 (D) 4

28. Given  $2x + 3 \geq 9$ , the range of values of  $x$  is

- (A)  $x > 6$   
 (B)  $x \geq 6$   
 (C)  $x > 3$   
 (D)  $x \geq 3$

29. If  $x = -2$ ,  $y = 3$ ,  $t = 2$ , then  $\left(\frac{x}{y}\right)^t =$

- (A)  $-\frac{4}{9}$   
 (B)  $\frac{4}{9}$   
 (C)  $\frac{4}{3}$   
 (D)  $\frac{9}{4}$

30. When 6 is added to a number and the sum is divided by three, the result is four. This statement written in mathematical symbols is

- (A)  $\frac{6+x}{3} = 4$   
 (B)  $\frac{6}{3} + x = 4$   
 (C)  $\frac{6+x}{3} = \frac{4}{3}$   
 (D)  $6 + \frac{x}{3} = 4$

31. The values of  $x$  and  $y$  which satisfy the equations  $x + 2y = 27$  and  $2x - y = 19$  are respectively

- (A) 15 and 10  
 (B) 10 and 15  
 (C) 7 and 13  
 (D) 13 and 7

32. The volume of a cube of edge 10 cm is

- (A)  $30 \text{ cm}^3$   
 (B)  $100 \text{ cm}^3$   
 (C)  $300 \text{ cm}^3$   
 (D)  $1000 \text{ cm}^3$

33. 2500 millimetres expressed in metres is

- (A) 0.25  
 (B) 2.5  
 (C) 25  
 (D) 250

34. A boy leaves home at 09:15 hours and arrives at school at 10:05 hours. If he travels non-stop at an average speed of  $6 \text{ kmh}^{-1}$ , what is the distance, in km, of his home from school?

- (A) 2 km  
 (B) 5 km  
 (C) 6 km  
 (D) 9 km

35. The distance around the edge of a circular pond is 88 m. The radius, in metres, is

- (A)  $176\pi$   
 (B)  $88\pi$   
 (C)  $\frac{88}{\pi}$   
 (D)  $\frac{88}{2\pi}$

36. A man leaves home at 22 : 15 hrs and reaches his destination in the same time zone at 04 : 00 hrs on the following day. How many hours did the journey take?

- (A) 5
- (B)  $5\frac{3}{4}$
- (C) 6
- (D)  $6\frac{1}{4}$

Item 37 refers to the diagram below

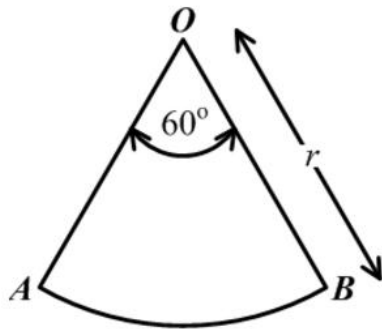

37.  $AOB$  is a sector of a circle such that angle  $AOB = 60^\circ$  and  $OB$  is  $r$  units long. The area of  $AOB$  is

- (A)  $\frac{1}{3}\pi r$
- (B)  $\frac{1}{6}\pi r$
- (C)  $\frac{1}{3}\pi r^2$
- (D)  $\frac{1}{6}\pi r^2$

38. Which of the figures below, **not drawn to scale**, has an area equal to  $\frac{1}{2}(3+4)\times 5$  square units?

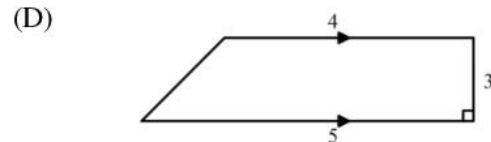
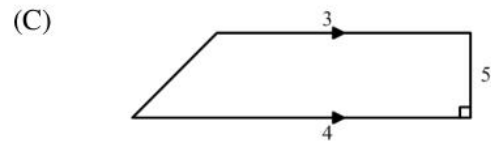
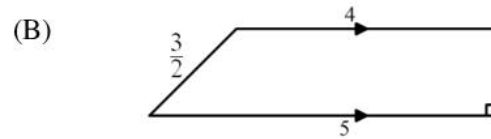
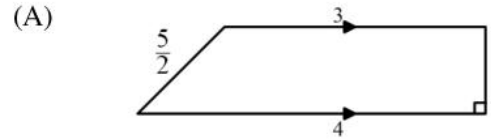

39. The area of a triangle is  $30\text{ cm}^2$  and its base is 10 cm . What is the perpendicular height, in cm, of the triangle?

- (A) 6
- (B) 12
- (C) 13
- (D) 17

40. The median of the numbers: 1, 1, 5, 5, 6, 7, 7, 7, 7, 8 is

- (A) 5.4
- (B) 6
- (C) 6.5
- (D) 7

41. Six hundred students write an examination. The probability of a randomly selected student failing the examination is  $\frac{1}{5}$ . How many students are expected to pass?

- (A) 120
- (B) 480
- (C) 500
- (D) 600

42. The lengths of 30 cabbage leaves were measured, to the nearest cm, and the information grouped as shown in the table below.

Length of Leaf (cm)	10-14	15-19	20-24	25-29
Frequency	3	8	12	7

The limits of the class intervals are

- (A) 3,8,12,7
- (B) 5,5,5,5
- (C) 9.5,14.5,19.5,24.5,29.5
- (D) 10,14,15,19,20,24,25,29

Item 43 refers to the following bar chart

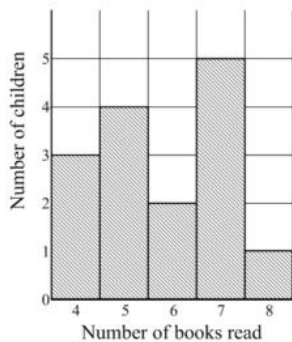

43. The bar chart above shows the number of books read by the children who took part in a survey. How many children took part in the survey?

- (A) 5
- (B) 15
- (C) 75
- (D) 87

44. Each of the letters in the word 'CHANCE' is written on a slip of paper similar in size and shape. The slips of paper are then placed in a bag and thoroughly shaken. What is the probability of drawing a letter 'C'?

- (A)  $\frac{1}{6}$
- (B)  $\frac{1}{5}$
- (C)  $\frac{1}{3}$
- (D)  $\frac{2}{3}$

Item 45 refers to the following diagram

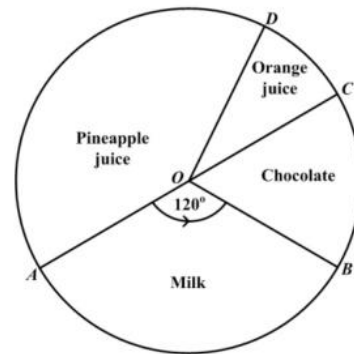

45. The pie chart above shows the preference in drinks of a group of students. If 12 students prefer chocolate, then the TOTAL number of students is

- (A) 48
- (B) 72
- (C) 180
- (D) 360

46. Which of the following represents the equation of a straight line?

- (A)  $y = 2x + 3$
- (B)  $y = \frac{4}{x}$
- (C)  $y = x^2 - 4$
- (D)  $y = x^2 + 2x - 5$

Item 47 refers to the graph below

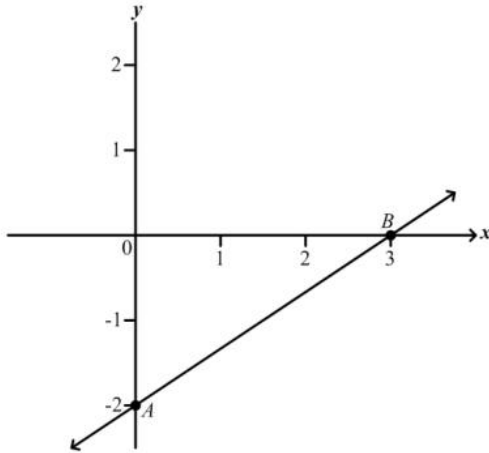

47. The straight line  $AB$  cuts the  $Y$  axis at

- (A)  $(0, 3)$
- (B)  $(0, 2)$
- (C)  $(3, -2)$
- (D)  $(0, -2)$

Item 48 refers to the following graph

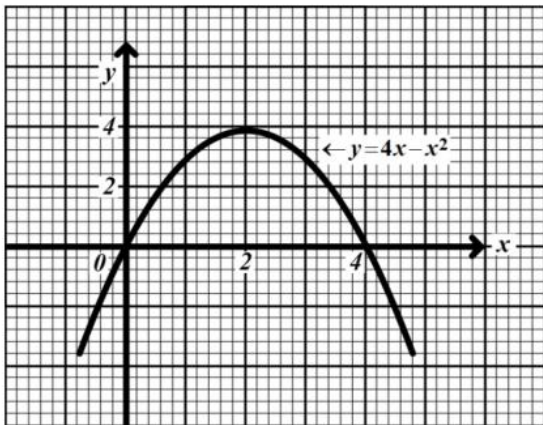

48. The values of  $x$  for which  $y = 4x - x^2$  intersects  $y = 0$  are

- (A)  $x = 0$  and  $x = 4$
- (B)  $x = 0$  and  $x = 2$
- (C)  $x = 0$  and  $x = -4$
- (D)  $x = 2$  and  $x = 4$

49. Which of the following diagrams illustrates a function?

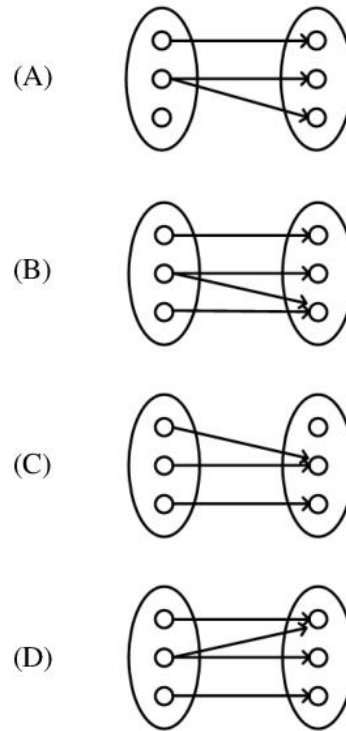

50. If  $f(x) = x^2 - x - 1$ , then  $f(-5) =$

- (A)  $-31$
- (B)  $19$
- (C)  $24$
- (D)  $29$

Item 51 refers to the following diagram of a function.

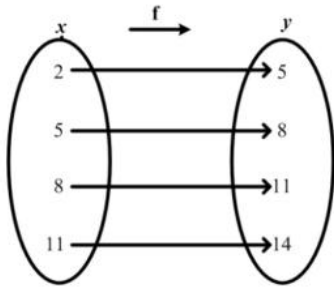

51. Which of the following best describes the function?

- (A)  $f(x) = 3 - x$
- (B)  $y = x$
- (C)  $f(x) = x + 3$
- (D)  $x = y + 3$

Item 52 refers to the diagram below.

52.  $AC$  and  $DE$  are straight lines intersecting at  $B$

Angle  $DBA = 58^\circ$

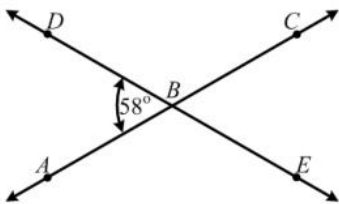

The measure of angle  $ABE$  is

- (A)  $58^\circ$
- (B)  $122^\circ$
- (C)  $142^\circ$
- (D)  $302^\circ$

53. If the sum of the interior angles of a polygon is 4 right angles, the polygon is a

- (A) triangle
- (B) hexagon
- (C) pentagon
- (D) quadrilateral

54. A ship sailed 8 km due east from  $A$  to  $B$  then sailed 6 km due north to  $C$ . Which diagram below BEST represents the path of the ship?

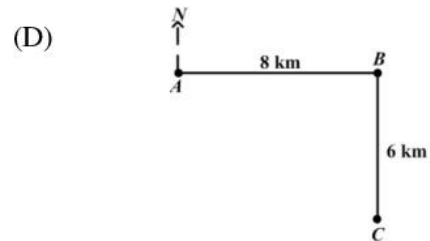
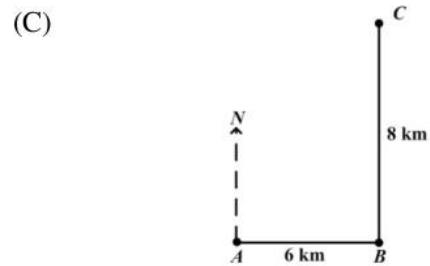
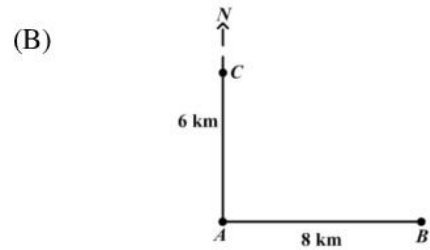
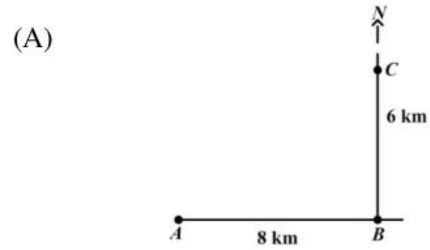

55. A plane is heading in a direction of  $045^\circ$  and changes course in a clockwise direction to  $135^\circ$ . The angle through which the plane turns is
- (A)  $45^\circ$   
 (B)  $90^\circ$   
 (C)  $135^\circ$   
 (D)  $270^\circ$

56. The image of the point  $P(-3, 2)$  under the translation  $\begin{pmatrix} 2 \\ 1 \end{pmatrix}$  is
- (A)  $(-5, 3)$   
 (B)  $(-2, 4)$   
 (C)  $(-1, 3)$   
 (D)  $(-1, 1)$

Item 57 refers to the following diagram.

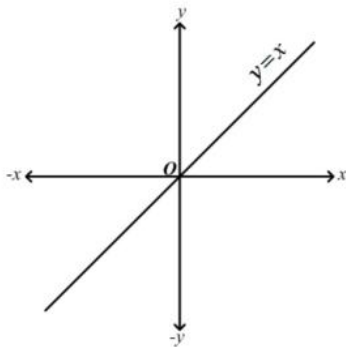

57. In the diagram above, if the line  $y = x$  is rotated anti-clockwise about  $O$  through  $90^\circ$ , what is its image?
- (A)  $y = 0$   
 (B)  $x = 0$   
 (C)  $y = x$   
 (D)  $y = -x$

58. A ladder 5 metres long is leaning against a vertical wall. The foot of the ladder is 3 m away from the wall. How far up the wall does the ladder reach?
- (A) 4 m  
 (B) 6 m  
 (C) 8 m  
 (D) 15 m

Item 59 refers to the diagram below

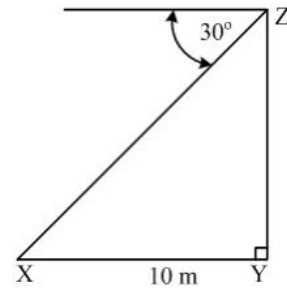

59. The diagram above, **not drawn to scale**, shows that the angle of depression of a point  $X$  from  $Z$  is  $30^\circ$ . If  $X$  is 10 metres from  $Y$ , the height of  $YZ$ , in metres, is
- (A)  $10 \tan 60^\circ$   
 (B)  $10 \cos 60^\circ$   
 (C)  $10 \tan 30^\circ$   
 (D)  $10 \sin 30^\circ$
60. In a triangle  $ABC$ , angle  $A = x^\circ$  and angle  $B = 2x^\circ$ . What is the size of angle  $C$ ?
- (A)  $60^\circ$   
 (B)  $45^\circ$   
 (C)  $(180 - 3x)^\circ$   
 (D)  $\left(\frac{180}{3x}\right)^\circ$

**IF YOU FINISH BEFORE TIME IS CALLED, CHECK YOUR WORK ON THIS TEST.**



↑ AFFIX SEAL HERE ↑

**CANDIDATE –PLEASE NOTE!**

You must sign below and return this booklet with the Answer Sheet. Failure to do so may result in disqualification.

\_\_\_\_\_  
SignatureTEST CODE **01234010**

JANUARY 2011

**FORM TP 2007104**

**CARIBBEAN EXAMINATIONS COUNCIL**  
**SECONDARY EDUCATION CERTIFICATE**  
**EXAMINATION**  
**MATHEMATICS**  
**Paper 01 – General Proficiency**  
*90 minutes*

04 JANUARY 2011 (p.m.)

**READ THE FOLLOWING DIRECTIONS CAREFULLY**

1. In addition to this test booklet, you should have an answer sheet.
2. Calculators and mathematical tables may NOT be used for this paper.
3. **A list of formulae is provided on page 2 of this booklet.**
4. This test consists of 60 items. You will have 90 minutes to answer them.
5. Each item in this test has four suggested answers, lettered (A), (B), (C), (D). Read each item you are about to answer, and decide which choice is best.
6. On your answer sheet, find the number which corresponds to your item and blacken the space having the same letter as the answer you have chosen. Look at the sample item below.

Sample Item

$2a + 6a =$

- (A)  $8a$   
 (B)  $8a^2$   
 (C)  $12a$   
 (D)  $12a^2$

Sample Answer

The best answer to this item is “ $8a$ ”, so answer space (A) has been blackened.

7. If you want to change your answer, erase your old answer completely and fill in your new choice.
8. When you are told to begin, turn the page and work as quickly and as carefully as you can. If you cannot Answer an item, omit it and go on to the next one. You can return later to the item omitted. Your score will be the total number of correct answers.
9. You may do any rough work in the booklet.
10. Do not be concerned that the answer sheet provides spaces for more answers than there are items in this test.

**DO NOT TURN THIS PAGE UNTIL YOU ARE TOLD TO DO SO.**

Copyright © 2010 Caribbean Examinations Council ®.

**LIST OF FORMULAE**

Volume of a prism  $V = Ah$  where  $A$  is the area of a cross-section and  $h$  is the perpendicular length.

Volume of a cylinder  $V = \pi r^2 h$  where  $r$  is the radius of the base and  $h$  is the perpendicular height.

Volume of a right pyramid  $V = \frac{1}{3}Ah$  where  $A$  is the area of the base and  $h$  is the perpendicular height.

Circumference  $C = 2\pi r$  where  $r$  is the radius of the circle.

Area of a circle  $A = \pi r^2$  where  $r$  is the radius of the circle.

Area of Trapezium  $A = \frac{1}{2}(a + b)h$  where  $a$  and  $b$  are the lengths of the parallel sides and  $h$  is the perpendicular distance between the parallel sides.

Roots of quadratic equations If  $ax^2 + bx + c = 0$ ,  
 then  $x = \frac{-b \pm \sqrt{b^2 - 4ac}}{2a}$

Trigonometric ratios

$$\sin \theta = \frac{\text{opposite side}}{\text{hypotenuse}}$$

$$\cos \theta = \frac{\text{adjacent side}}{\text{hypotenuse}}$$

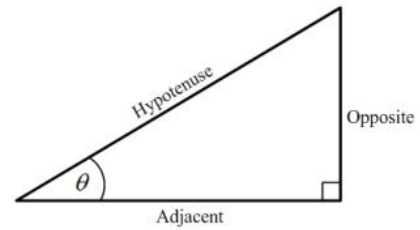
$$\tan \theta = \frac{\text{opposite side}}{\text{adjacent side}}$$

Area of triangle Area of  $\Delta = \frac{1}{2}bh$  where  $b$  is the length of the base and  $h$  is the perpendicular height

$$\text{Area of } \Delta ABC = \frac{1}{2}ab \sin C$$

$$\text{Area of } \Delta ABC = \sqrt{s(s-a)(s-b)(s-c)}$$

$$\text{where } s = \frac{a+b+c}{2}$$

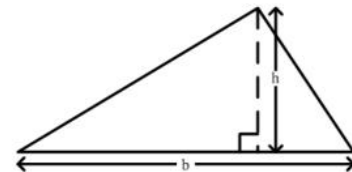

Sine rule  $\frac{a}{\sin A} = \frac{b}{\sin B} = \frac{c}{\sin C}$

Cosine rule  $a^2 = b^2 + c^2 - 2bc \cos A$

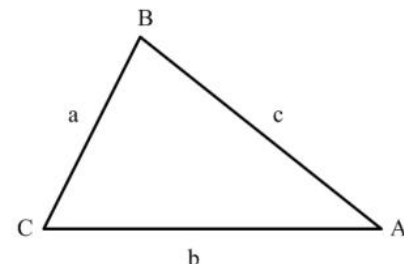

1. What percentage of 30 is 6 ?
- (A) 5%  
(B) 18%  
(C) 20%  
(D) 150%
2. The number 3.14063 written correct to 3 decimal places is
- (A) 3.140  
(B) 3.141  
(C) 3.146  
(D) 3.150
3. Express  $4\frac{3}{8}$  as a decimal correct to 3 significant figures.
- (A) 4.30  
(B) 4.37  
(C) 4.38  
(D) 4.40
4. There are 40 students in a class. Girls make up 60% of the class. 25% of the girls wear glasses. How many girls in the class wear glasses?
- (A) 6  
(B) 8  
(C) 10  
(D) 15
5. If \$560 is shared in the ratio 2 : 3 : 9, the difference between the largest and the smallest shares is
- (A) \$ 80  
(B) \$240  
(C) \$280  
(D) \$360
6. If 60% of a number is 90, what is the number?
- (A) 30  
(B) 54  
(C) 150  
(D) 180
7.  $\left(-\frac{1}{2}\right)^3$  is the same as
- (A)  $-\frac{1}{8}$   
(B)  $-\frac{1}{6}$   
(C)  $\frac{1}{8}$   
(D)  $\frac{1}{6}$
8. What is the highest Common Factor of the set of numbers {54, 72, 90} ?
- (A) 9  
(B) 18  
(C) 90  
(D) 1080
9. If  $3n$  is an odd number, which of the following is an even number?
- (A)  $3n-1$   
(B)  $3n-2$   
(C)  $3n+2$   
(D)  $3n+2n$

10. By the distributive law  $49 \times 17 + 49 \times 3 =$

- (A)  $52 + 66$
- (B)  $52 \times 66$
- (C)  $49 + 20$
- (D)  $49 \times 20$

11. Which of the following sets is equivalent to  $\{a, b, c, d\}$ ?

- (A)  $\{4\}$
- (B)  $\{a, b, c\}$
- (C)  $\{p, q, r, s\}$
- (D)  $\{1, 2, 3, 4, 5\}$

12. If  $U = \{1, 3, 5, 6, 8\}$  and  $A = \{3, 6\}$ , then the number of elements in  $A'$  is

- (A) 2
- (B) 3
- (C) 4
- (D) 8

Item 13 refers to the Venn diagram below.

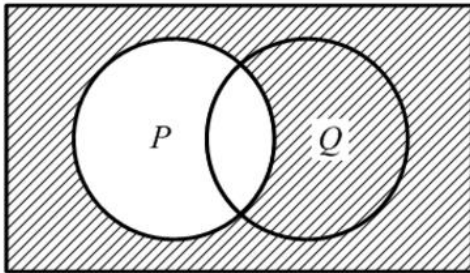

13. In the Venn diagram above, the shaded area represents

- (A)  $P'$
- (B)  $(P \cup Q)'$
- (C)  $P' \cap Q'$
- (D)  $P \cap Q'$

Item 14 refers to the Venn diagram below.

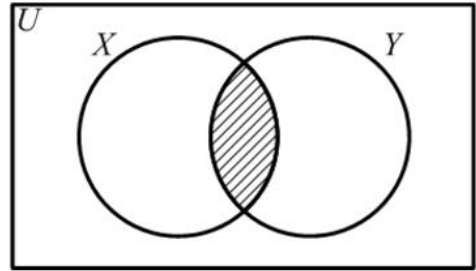

14. In the figure above,  $X$  represents the set of multiples of four.  $Y$  represents the set of multiples of 5. The shaded region represents the set of all multiples of

- (A) 8
- (B) 9
- (C) 10
- (D) 20

15. A plot of land is valued at \$18000. Land tax is charged at a rate of \$0.70 per \$100. What is total amount of tax to be paid for the land?

- (A) \$110.00
- (B) \$126.00
- (C) \$180.70
- (D) \$257.15

16. A dress which costs \$180 is being sold at a discount of 10%. The amount of the discount is

- (A) \$ 1.80
- (B) \$ 10.00
- (C) \$ 18.00
- (D) \$170.00

Item 17 refers to the table below.

House Insurance	50 ¢ per \$100
Contents Insurance	25 ¢ per \$100

17. The table above shows the rates charged by an insurance company. How much will a person pay for his insurance, if his house is valued at \$50 000, and the contents at \$10 000 ?
- (A) \$225  
(B) \$275  
(C) \$450  
(D) \$500
18. A man bought a cow for \$200 and sold it to gain \$50. What was his gain as a percentage of the cost price?
- (A) 5%  
(B) 15%  
(C) 20%  
(D) 25%
19. If the simple interest on \$800 for 3 years is \$54. What is the rate of interest per annum?
- (A)  $\frac{4}{9}\%$   
(B)  $2\frac{1}{4}\%$   
(C) 5%  
(D) 44%
20. A customer buys a table on hire purchase. He makes a deposit of \$306 and pays six monthly installments of \$60 each. The TOTAL cost to the customer is
- (A) \$360  
(B) \$366  
(C) \$666  
(D) \$966
21. A man pays 60 cents for every 200 m<sup>3</sup> of gas used, plus a fixed charge of \$13.75. How much does he pay when he uses 55000 m<sup>3</sup> of gas?
- (A) \$151.25  
(B) \$165.00  
(C) \$175.25  
(D) \$178.75
22. A company employs 12 gardeners at \$26 per day, and 8 clerks at \$17 per day. What is the mean daily wage, in dollars, of the 20 employees?
- (A) \$20.00  
(B) \$21.50  
(C) \$22.40  
(D) \$31.50
23.  $\frac{4}{5x} + \frac{2}{5x} =$
- (A)  $\frac{6}{25x}$   
(B)  $\frac{8}{25x}$   
(C)  $\frac{6}{10x}$   
(D)  $\frac{6}{5x}$
24. If  $x$  is an integer that satisfies the inequality  $4 < 2x \leq 6$ , then
- (A)  $2 < x \leq 3$   
(B)  $-2 < x \leq 3$   
(C)  $-3 < x \leq 2$   
(D)  $-3 \leq x < -2$

25. The expression  $-2(x-4)$  is the same as
- (A)  $-2x-8$   
 (B)  $-2x-4$   
 (C)  $2x+4$   
 (D)  $-2x+8$
26.  $3a(a+2b)-b(2a-3b) =$
- (A)  $3a^2-ab+3b^2$   
 (B)  $3a^2+4ab+3b^2$   
 (C)  $3a^2+4ab-3b^2$   
 (D)  $3a^2+8ab-3b^2$
27. If  $m * n = \sqrt{mn - n^2}$ , then  $5 * 3 =$
- (A)  $\sqrt{6}$   
 (B) 3  
 (C)  $\sqrt{15}$   
 (D) 6
28. John has  $x$  marbles and Max has twice as many. Max gives Tom 5 of his marbles. How many marbles does Max now have?
- (A)  $x+5$   
 (B)  $x-5$   
 (C)  $2x+5$   
 (D)  $2x-5$
29. Given that  $3(x-1) - 2(x-1) = 7$ , then the value of  $x$  is
- (A) 6  
 (B) 7  
 (C) 8  
 (D) 9
30. When  $x$  is subtracted from a number and the result is multiplied by 3, the final answer is 21. What is the **original** number?
- (A) 1  
 (B) 3  
 (C) 10  
 (D) 15
31. The sum of two numbers  $x$  and  $y$ , is 18, and their difference is 14. Which pair of equations describes the above statement?
- (A)  $x + y = 18$   
 $x - y = 14$   
 (B)  $x + y = 32$   
 $x - y = 4$   
 (C)  $2x + 2y = 18$   
 $2x - 2y = 14$   
 (D)  $xy = 18$   
 $x - y = 14$
32. The volume of a cube whose edge is 6 cm long is
- (A)  $18 \text{ cm}^3$   
 (B)  $36 \text{ cm}^3$   
 (C)  $72 \text{ cm}^3$   
 (D)  $216 \text{ cm}^3$
33. 2500 millimetres expressed in metres is
- (A) 0.25  
 (B) 2.5  
 (C) 25  
 (D) 250

34. The distance around the edge of a circular pond is 88 m. The radius, in metres is
- (A)  $88\pi$
- (B)  $176\pi$
- (C)  $\frac{88}{\pi}$
- (D)  $\frac{88}{2\pi}$

35. A car travels 80 kilometres in  $2\frac{1}{2}$  hours. What is its speed in kilometers per hour?
- (A) 6
- (B) 32
- (C) 82.5
- (D) 200

Item 36 refers to the diagram below.

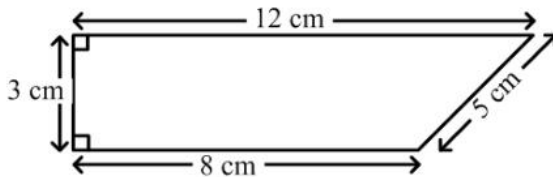

36. The area of the quadrilateral above is
- (A)  $24 \text{ cm}^2$
- (B)  $28 \text{ cm}^2$
- (C)  $30 \text{ cm}^2$
- (D)  $36 \text{ cm}^2$
37. The lengths of the sides of a triangle are  $x$ ,  $2x$  and  $2x$  centimetres. If the perimeter is 20 centimetres, what is the value of  $x$ , in centimeters?
- (A) 4
- (B) 5
- (C) 8
- (D) 10

Item 38 refers to the following diagram

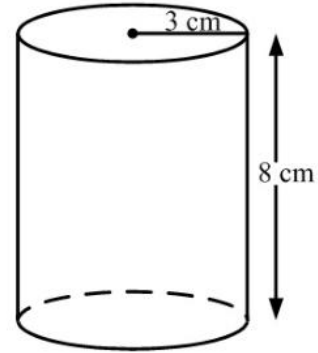

38. The diagram above, **not drawn to scale**, shows a cylinder of radius 3 cm and height of 8 cm. The volume is.
- (A)  $12\pi \text{ cm}^3$
- (B)  $48\pi \text{ cm}^3$
- (C)  $72\pi \text{ cm}^3$
- (D)  $192\pi \text{ cm}^3$
39. A man leaves home at 22:15 hrs and reaches his destination at 04:00 hrs on the following day in the same time zone. How many hours did the journey take?
- (A) 5
- (B)  $5\frac{3}{4}$
- (C) 6
- (D)  $6\frac{1}{4}$

Items 40-42 refer to the diagram below which shows the sport chosen by 160 boys who participated in a games evening at their school

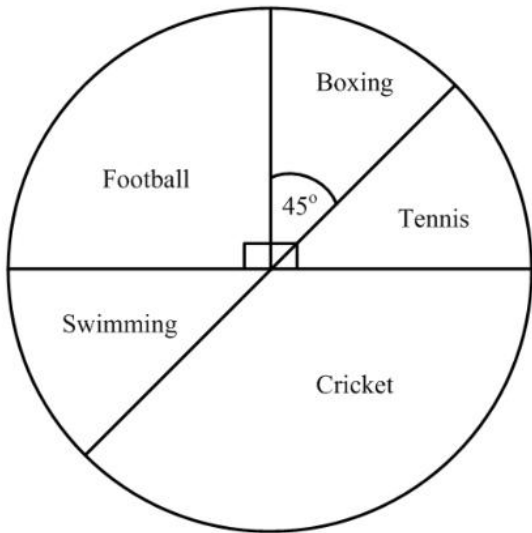

40. The number of boys who chose football is

- (A) 40
- (B) 90
- (C) 110
- (D) 150

41. How many boys participated in cricket?

- (A) 54
- (B) 60
- (C) 110
- (D) 120

42. The probability that a boy chosen at random participated in boxing is

- (A)  $\frac{1}{8}$
- (B)  $\frac{1}{4}$
- (C)  $\frac{1}{2}$
- (D)  $\frac{7}{8}$

43. The median of the numbers: 1, 1, 5, 5, 6, 7, 7, 7, 7, 8 is

- (A) 5.4
- (B) 6
- (C) 6.5
- (D) 7

44. A bag contains 2 red, 4 yellow and 6 blue balls. The probability of drawing a blue ball from the bag at random is

- (A)  $\frac{1}{2}$
- (B)  $\frac{1}{3}$
- (C)  $\frac{1}{6}$
- (D)  $\frac{6}{11}$

Item 45 refers to the following table.

Length of Leaf (cm)	10-14	15-19	20-24	25-29
Frequency	3	8	12	7

45. The lengths of 30 cabbage leaves were measured, to the nearest cm, and the information grouped as shown in the table above.

The class boundaries are

- (A) 3, 8, 12, 7
- (B) 5, 5, 5, 5
- (C) 9.5, 14.5, 19.5, 24.5, 29.5
- (D) 10, 14, 15, 19, 20, 24, 25, 29

46. Which of the following line graphs represents  $\{x: -2 < x \leq 4\}$  ?

- (A)
- (B)
- (C)
- (D)

47. If  $f(x) = x^2 - x - 1$ , then  $f(-5) =$

- (A) -31
- (B) 29
- (C) 24
- (D) 31

Item 48 refers to the graph below.

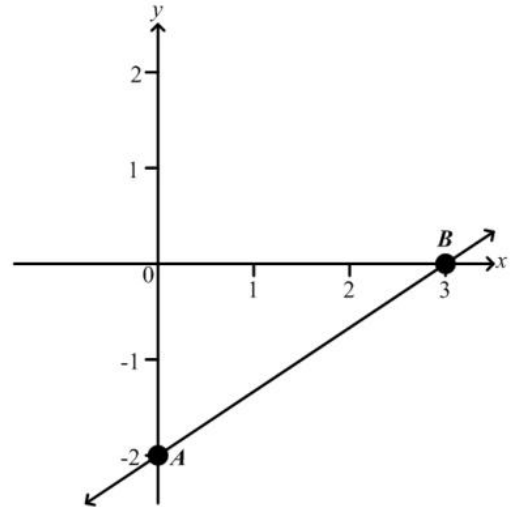

48. The straight line  $AB$  cuts the  $y$  axis at

- (A) (0,3)
- (B) (0,2)
- (C) (3,-2)
- (D) (0,-2)

49. Which of the following represents the graph of a function?

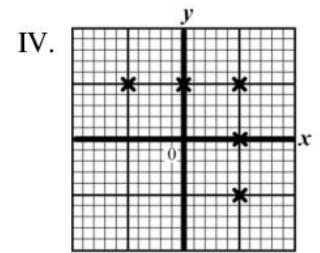
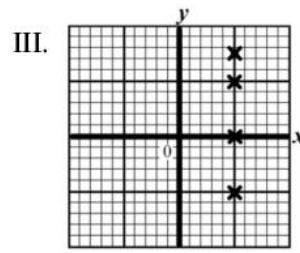
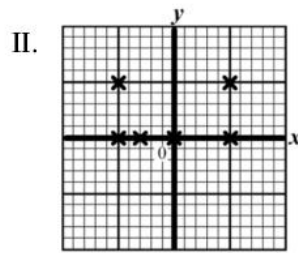
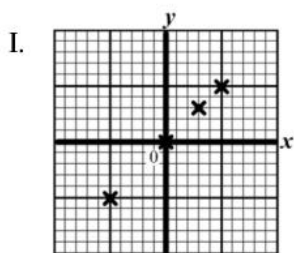

- (A) I
- (B) II
- (C) III
- (D) IV

50.

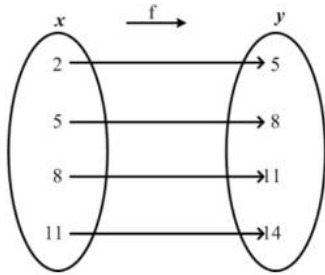

The arrow diagram above shows a function. Which of the following BEST describes the function?

- (A)  $f(x) = x + 3$
- (B)  $f(x) = y + 3$
- (C)  $x = y + 3$
- (D)  $y = x$

51. The range of  $f : x \rightarrow x^3$  for the domain  $\{-2, -1, 0, 1, 2\}$  is

- (A)  $\{0, 1, 8\}$
- (B)  $\{-2, -1, 0, 1, 2\}$
- (C)  $\{-6, -3, 0, 3, 6\}$
- (D)  $\{-8, -1, 0, 1, 8\}$

Item 52 refers to the diagram below of a construction. With centre  $A$ , an arc  $BC$  is drawn. With centre  $B$ , and the same radius, the arc  $PCQ$  is drawn.

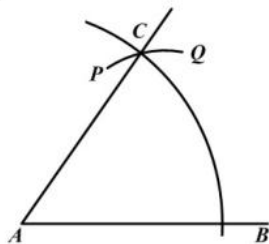

52. What is the measure of  $\angle BAC$ ?
- (A)  $30^\circ$
  - (B)  $45^\circ$
  - (C)  $60^\circ$
  - (D)  $75^\circ$

Item 53 refers to the diagram below.

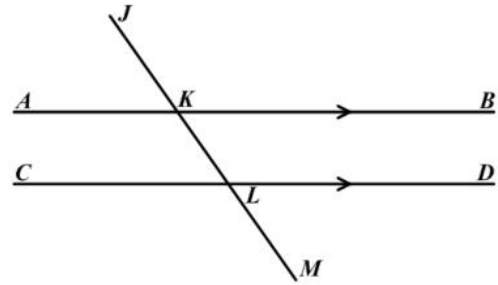

53. In the diagram,  $AB$  is parallel to  $CD$ , and  $\angle JKB = 125^\circ$ .

$\angle MLD$  is

- (A)  $45^\circ$
- (B)  $55^\circ$
- (C)  $90^\circ$
- (D)  $125^\circ$

Item 54 refers to the following diagram.

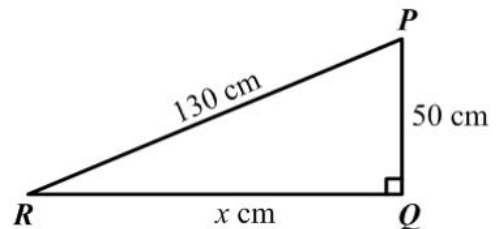

54. In the right-angled triangle above, **not drawn to scale**,  $\hat{Q} = 90^\circ$ ,  $PQ = 50$  cm,  $PR = 130$  cm and  $RQ = x$  cm.

$\tan \hat{P}RQ =$

- (A)  $\frac{50}{x}$
- (B)  $\frac{x}{50}$
- (C)  $\frac{50}{130}$
- (D)  $\frac{x}{130}$

Item 55 refers to the diagram below.

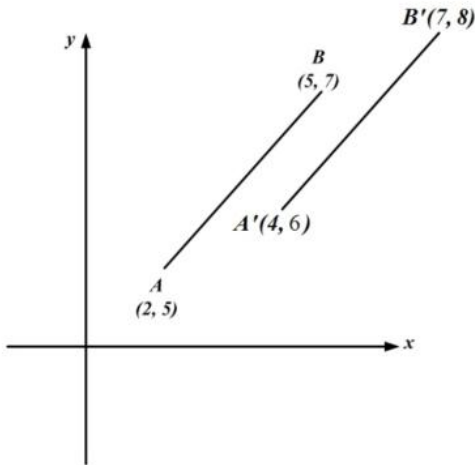

55. In the diagram above, the translation by which  $AB$  is mapped onto  $A'B'$  is represented by

- (A)  $\begin{pmatrix} 1 \\ 1 \end{pmatrix}$
- (B)  $\begin{pmatrix} 2 \\ 1 \end{pmatrix}$
- (C)  $\begin{pmatrix} 3 \\ 2 \end{pmatrix}$
- (D)  $\begin{pmatrix} 5 \\ 3 \end{pmatrix}$

Item 56 refers to the diagram below.

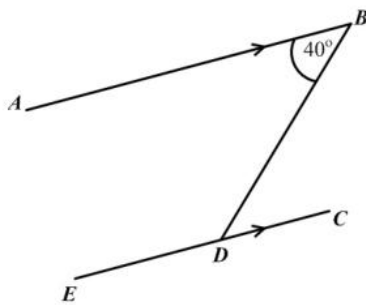

56.  $AB$  is parallel to  $EC$ . Calculate  $\angle BDE$ .

- (A)  $40^\circ$
- (B)  $50^\circ$
- (C)  $140^\circ$
- (D)  $180^\circ$

Item 57 refers to the diagram below.

57.

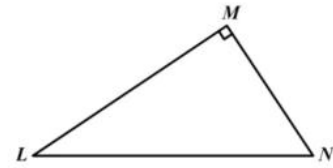

The triangle  $LMN$  is rotated in a clockwise direction about  $L$  through an angle of  $90^\circ$ . What is its image?

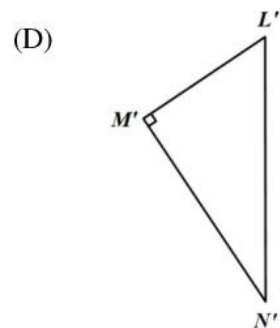
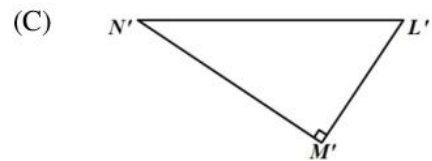
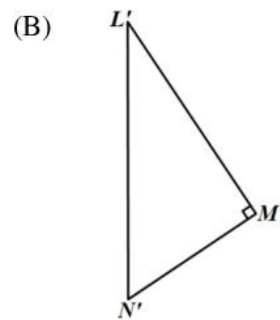
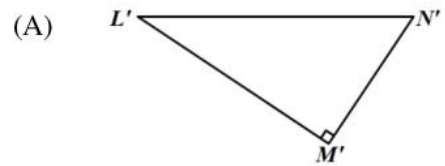

Item 58 refers to the following diagram.

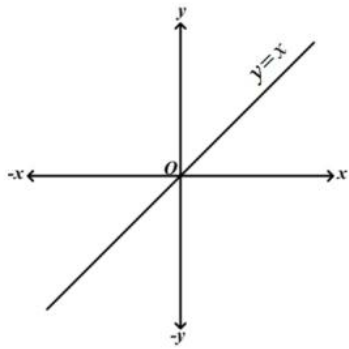

58. In the diagram above, if the line  $y = x$  is rotated anti-clockwise about  $O$  through  $90^\circ$ , what is its image?

- (A)  $y = 0$
- (B)  $x = 0$
- (C)  $y = x$
- (D)  $y = -x$

Item 59 refers to the following diagram.

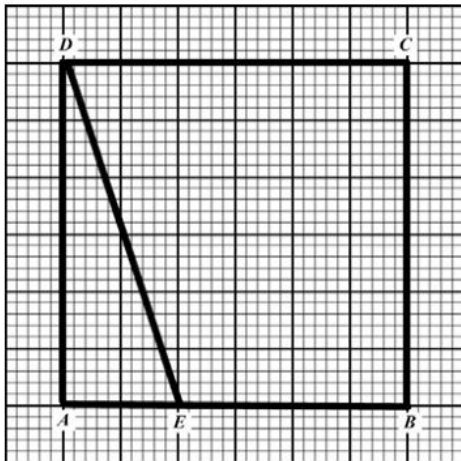

59. How many triangles congruent to  $\triangle ADE$  would be needed to cover the rectangle  $ABCD$  entirely?

- (A) 8
- (B) 6
- (C) 4
- (D) 2

60. In each of the diagrams shown below,  $A'$  is the image of  $A$ . Which of the following diagrams shows a reflection in the  $x$  axis?

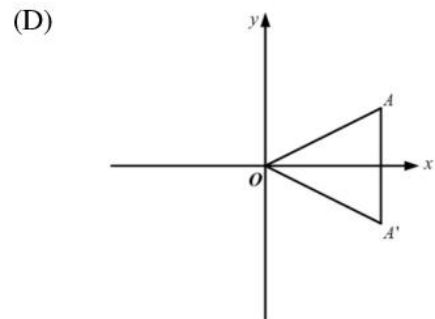
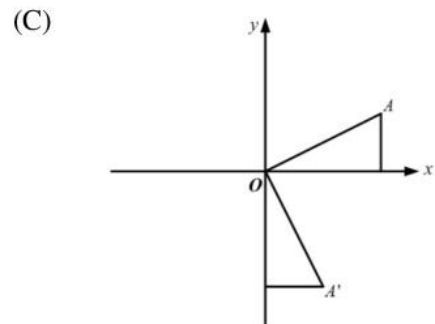
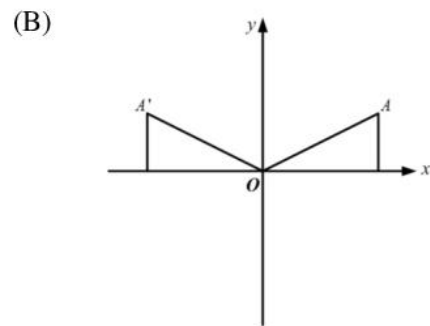
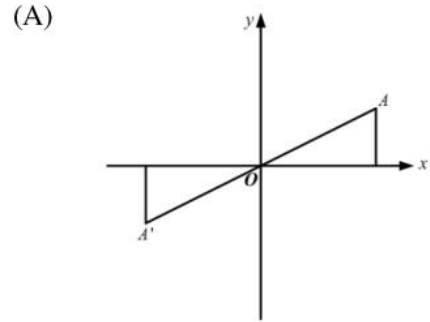

**IF YOU FINISH BEFORE TIME IS CALLED, CHECK YOUR WORK ON THIS TEST.**

↑ AFFIX SEAL HERE ↑

**CANDIDATE –PLEASE NOTE!**

You must sign below and return this booklet with the Answer Sheet. Failure to do so may result in disqualification.

\_\_\_\_\_  
SignatureTEST CODE **01234010**

MAY/JUNE 2011

**FORM TP 2007104**

**CARIBBEAN EXAMINATIONS COUNCIL**  
**SECONDARY EDUCATION CERTIFICATE**  
**EXAMINATION**  
**MATHEMATICS**  
**Paper 01 – General Proficiency**  
*90 minutes*

18 MAY 2011 (p.m.)

**READ THE FOLLOWING DIRECTIONS CAREFULLY**

1. In addition to this test booklet, you should have an answer sheet.
2. Calculators and mathematical tables may NOT be used for this paper.
3. **A list of formulae is provided on page 2 of this booklet.**
4. This test consists of 60 items. You will have 90 minutes to answer them.
5. Each item in this test has four suggested answers, lettered (A), (B), (C), (D). Read each item you are about to answer, and decide which choice is best.
6. On your answer sheet, find the number which corresponds to your item and blacken the space having the same letter as the answer you have chosen. Look at the sample item below.

Sample Item

$2a + 6a =$

- (A)  $8a$   
 (B)  $8a^2$   
 (C)  $12a$   
 (D)  $12a^2$

Sample Answer

The best answer to this item is “ $8a$ ”, so answer space (A) has been blackened.

7. If you want to change your answer, erase your old answer completely and fill in your new choice.
8. When you are told to begin, turn the page and work as quickly and as carefully as you can. If you cannot Answer an item, omit it and go on to the next one. You can return later to the item omitted. Your score will be the total number of correct answers.
9. You may do any rough work in the booklet.
10. Do not be concerned that the answer sheet provides spaces for more answers than there are items in this test.

**DO NOT TURN THIS PAGE UNTIL YOU ARE TOLD TO DO SO.**

Copyright © 2010 Caribbean Examinations Council ®.

**LIST OF FORMULAE**

- Volume of a prism  $V = Ah$  where  $A$  is the area of a cross-section and  $h$  is the perpendicular length.
- Volume of a cylinder  $V = \pi r^2 h$  where  $r$  is the radius of the base and  $h$  is the perpendicular height.
- Volume of a right pyramid  $V = \frac{1}{3} Ah$  where  $A$  is the area of the base and  $h$  is the perpendicular height.
- Circumference  $C = 2\pi r$  where  $r$  is the radius of the circle.
- Arc length  $S = \frac{\theta}{360} \times 2\pi r$  where  $\theta$  is the angle of the sector.
- Area of a circle  $A = \pi r^2$  where  $r$  is the radius of the circle.
- Area of a sector  $A = \frac{\theta}{360} \times \pi r^2$  where  $\theta$  is the angle of the sector.
- Area of Trapezium  $A = \frac{1}{2}(a+b)h$  where  $a$  and  $b$  are the lengths of the parallel sides and  $h$  is the perpendicular distance between the parallel sides.

Roots of quadratic equations If  $ax^2 + bx + c = 0$ , then  $x = \frac{-b \pm \sqrt{b^2 - 4ac}}{2a}$

- Trigonometric ratios
- $$\sin \theta = \frac{\text{opposite side}}{\text{hypotenuse}}$$
- $$\cos \theta = \frac{\text{adjacent side}}{\text{hypotenuse}}$$
- $$\tan \theta = \frac{\text{opposite side}}{\text{adjacent side}}$$

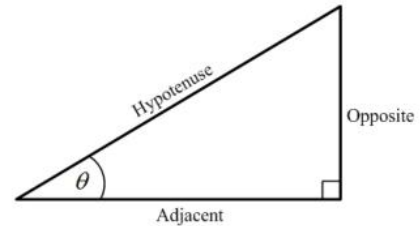

Area of triangle Area of  $\Delta = \frac{1}{2}bh$  where  $b$  is the length of the base and  $h$  is the perpendicular height

$$\text{Area of } \Delta ABC = \frac{1}{2} ab \sin C$$

$$\text{Area of } \Delta ABC = \sqrt{s(s-a)(s-b)(s-c)}$$

$$\text{where } s = \frac{a+b+c}{2}$$

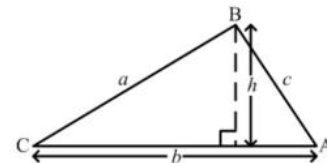

Sine rule  $\frac{a}{\sin A} = \frac{b}{\sin B} = \frac{c}{\sin C}$

Cosine rule  $a^2 = b^2 + c^2 - 2bc \cos A$

1. In scientific notation, 170.04 is written as
- (A)  $0.17004 \times 10^3$   
(B)  $1.7004 \times 10^2$   
(C)  $17.004 \times 10^1$   
(D)  $1.7004 \times 10^{-1}$
2. What percentage of 340 is 425
- (A) 80%  
(B) 85%  
(C) 125%  
(D) 152%
3. Ann and Betty shared a sum of money in the ratio 2:3 respectively. Ann received \$120. What was Betty's share?
- (A) \$ 72  
(B) \$ 80  
(C) \$180  
(D) \$300
4.  $11.1 \div 0.01$  is equal to
- (A) 110  
(B) 111  
(C) 1100  
(D) 1110
5. If 60% of a number is 90, what is the number?
- (A) 30  
(B) 54  
(C) 150  
(D) 180
6. The EXACT value of  $\frac{37.26 \div 1.8}{1000}$  is
- (A) 0.207  
(B) 0.0207  
(C) 20.7000  
(D) 20700
7.  $-\left(\frac{1}{2}\right)^3$  is the same as
- (A)  $-\frac{1}{8}$   
(B)  $-\frac{1}{6}$   
(C)  $\frac{1}{8}$   
(D)  $\frac{1}{6}$
8. The H.C.F. of 12, 15 and 60 is
- (A) 1  
(B) 3  
(C) 12  
(D) 60
9. If  $3n$  is an odd number, which of the following is an even number?
- (A)  $3n - 1$   
(B)  $3n - 2$   
(C)  $3n + 2$   
(D)  $3n + 2n$

10. What is the least number of plums that can be shared equally among 6, 9 or 12 children?

(A) 27  
 (B) 36  
 (C) 54  
 (D) 72

11. Which of the following sets is equivalent to  $\{a, b, c, d\}$ ?

(A)  $\{4\}$   
 (B)  $\{a, b, c\}$   
 (C)  $\{p, q, r, s\}$   
 (D)  $\{1, 2, 3, 4, 5\}$

12. Which of the following sets is defined by  $\{x \in \mathbb{Z} : -2 \leq x \leq 4\}$

(A)  $\{1, 2, 3, 4\}$   
 (B)  $\{0, 1, 2, 3, 4\}$   
 (C)  $\{-1, 0, 1, 2, 3\}$   
 (D)  $\{-2, -1, 0, 1, 2, 3, 4\}$

13. If  $P = \{a, b\}$  then the number of subsets of  $P$  is

(A) 2  
 (B) 3  
 (C) 4  
 (D) 8

Item 14 refers to the Venn diagram below.

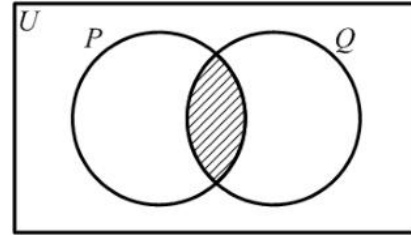

14. If  $P = \{\text{Factors of 6}\}$  and  $Q = \{\text{Factors of 4}\}$ , then the shaded region represents

(A)  $\{\}$   
 (B)  $\{1, 2\}$   
 (C)  $\{4, 6, 8, \dots\}$   
 (D)  $\{12, 24, 36, \dots\}$

15.  $3\frac{1}{4}\%$  of \$500 is

(A) \$ 1.62  
 (B) \$15.52  
 (C) \$16.00  
 (D) \$16.25

16. During a sale, a shop allows 20% discount off the marked price of clothing. What will a customer pay for a dress with a marked price of \$30?

(A) \$10  
 (B) \$20  
 (C) \$24  
 (D) \$30

17. A man bought a calf for \$200 and sold it for \$250. What was his gain as a percentage of the cost price?

(A) 5%  
 (B) 15%  
 (C) 20%  
 (D) 25%

18. How much does a customer pay for an article marked at \$50.00 before taxes if a sales tax of 6% is charged?
- (A) \$56.00  
(B) \$53.00  
(C) \$47.00  
(D) \$44.00
19. At the end of any year, a car is worth 5% less than what it was worth at the beginning of the year. If a car was bought for \$10 000 in January 2009, its value in December 2009 was
- (A) \$9 000  
(B) \$9 025  
(C) \$9 500  
(D) \$9 995
20. If the simple interest on \$800 for 3 years is \$54. What is the rate of interest per annum?
- (A)  $\frac{4}{9}\%$   
(B)  $2\frac{1}{4}\%$   
(C) 5%  
(D) 44%
21. A man pays 60 cents for every 200 m<sup>3</sup> of gas used, plus a fixed charge of \$13.25. How much does he pay when he uses 55 000 m<sup>3</sup> of gas?
- (A) \$178.25  
(B) \$175.25  
(C) \$165.00  
(D) \$151.25
22. If \$7000 is borrowed at the rate of 5% per annum for 3 years, the simple interest is
- (A) \$ 105  
(B) \$ 210  
(C) \$ 370  
(D) \$1 050
23.  $\frac{4}{5x} + \frac{2}{5x} =$
- (A)  $\frac{6}{25x}$   
(B)  $\frac{8}{25x}$   
(C)  $\frac{6}{10x}$   
(D)  $\frac{6}{5x}$
24.  $(x - 2)(3x + 4) =$
- (A)  $3x^2 - 6x - 8$   
(B)  $3x^2 - 2x - 8$   
(C)  $3x^2 + 10x + 8$   
(D)  $3x^2 - 10x + 8$
25. If  $5x - 26 = x + 50$  then the value of  $x$  is
- (A) -12  
(B) -6  
(C) 6  
(D) 19

26.  $3x^2 \times 2x^3 =$

- (A)  $6x^5$   
 (B)  $6x^6$   
 (C)  $5x^6$   
 (D)  $72x^5$

27.  $P = \frac{m^2}{2-m}$ . When  $m = -3$ , the value of  $P$  is

- (A) 9  
 (B)  $\frac{9}{5}$   
 (C)  $\frac{-6}{5}$   
 (D) -6

28. For  $2x + 3 \geq 9$ , the range of values of  $x$  is

- (A)  $x \geq 3$   
 (B)  $x > 3$   
 (C)  $x \geq 6$   
 (D)  $x > 6$

29. John has  $x$  marbles and Max has twice as many. Max gives John 5 of his marbles. How many marbles does Max now have?

- (A)  $x + 5$   
 (B)  $x - 5$   
 (C)  $2x + 5$   
 (D)  $2x - 5$

30. If  $3 + \frac{2}{x} = 1$ , then the value of  $x$  is

- (A) -1  
 (B)  $\frac{1}{5}$   
 (C) 1  
 (D) 5

31. The values of  $x$  and  $y$  which satisfy the equations  $x + 2y = 27$  and  $2x - y = 19$  are respectively

- (A) 15 and 10  
 (B) 10 and 15  
 (C) 7 and 13  
 (D) 13 and 7

32. The diagram below shows a cylinder with diameter 6 cm and height 20 cm.

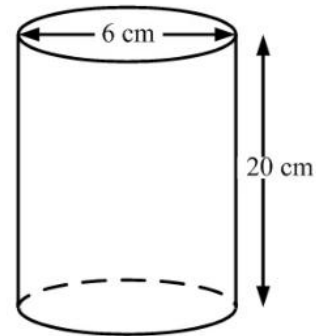

The volume in  $\text{cm}^3$ , of the cylinder is

- (A)  $180\pi$   
 (B)  $240\pi$   
 (C)  $360\pi$   
 (D)  $720\pi$

33. How many kilogrammes are there in one tonne?

- (A) 10  
 (B) 100  
 (C) 1 000  
 (D) 10 000

34. The distance around the edge of a circular pond is 88 m. The radius, in metres is

- (A)  $88\pi$   
 (B)  $176\pi$   
 (C)  $\frac{88}{\pi}$   
 (D)  $\frac{88}{2\pi}$

Item 35 refers to the quadrilateral below.

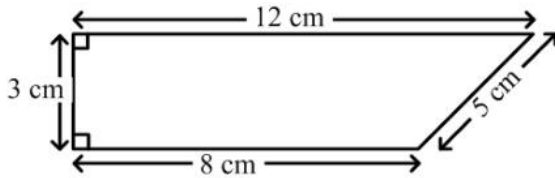

35. The area of the quadrilateral above is

- (A)  $24 \text{ cm}^2$
- (B)  $28 \text{ cm}^2$
- (C)  $30 \text{ cm}^2$
- (D)  $36 \text{ cm}^2$

Item 36 refers to the diagram below.

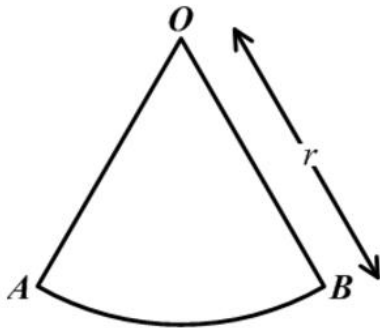

36.  $AOB$  is a sector of a circle such that angle  $AOB = 60^\circ$  and  $OB$  is  $r$  units long. The area of  $AOB$  is

- (A)  $\frac{1}{3}\pi r$
- (B)  $\frac{1}{6}\pi r$
- (C)  $\frac{1}{3}\pi r^2$
- (D)  $\frac{1}{6}\pi r^2$

37. The area of a triangle is  $30 \text{ cm}^2$  and its base is  $10 \text{ cm}$ . What is the perpendicular height, in  $\text{cm}$ , of the triangle?

- (A) 6
- (B) 12
- (C) 13
- (D) 17

38. The area of a rectangle is  $53.6 \text{ cm}^2$ . If the length is multiplied by four and the width is halved, the area would then be

- (A)  $26.8 \text{ cm}^2$
- (B)  $53.6 \text{ cm}^2$
- (C)  $107.2 \text{ cm}^2$
- (D)  $214.4 \text{ cm}^2$

Item 39 refers to the table below showing the frequency of scores obtained by students in a test.

Scores	2	3	5	6	8	11
Students	8	4	6	3	12	2

39. The modal score is

- (A) 8
- (B) 9
- (C) 10
- (D) 12

40. The perimeter of a square is  $48 \text{ cm}$ . What is the area in  $\text{cm}^2$ ?

- (A) 36
- (B) 72
- (C) 108
- (D) 144

41. The mean of the following numbers is 15.  
14, 10, 18,  $c$ , 21, 15, 14  
The value of  $c$  is.

- (A) 13  
(B) 14  
(C) 20  
(D) 91

42. A bag contains 2 red, 4 yellow and 6 blue balls.  
The probability of drawing a **blue** ball from  
the bag at random is

- (A)  $\frac{1}{6}$   
(B)  $\frac{1}{3}$   
(C)  $\frac{1}{2}$   
(D)  $\frac{6}{11}$

Items 43-45 refer to the diagram below which shows the sport chosen by 160 boys who participated in a games evening at their school

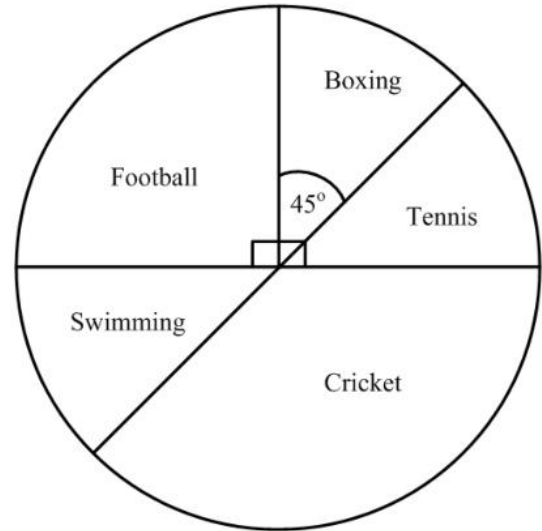

43. The number of boys who chose football is
- (A) 40  
(B) 90  
(C) 110  
(D) 150
44. The probability that a boy chosen at random participated in boxing is
- (A)  $\frac{7}{8}$   
(B)  $\frac{1}{2}$   
(C)  $\frac{1}{4}$   
(D)  $\frac{1}{8}$
45. How many boys participated in cricket?
- (A) 54  
(B) 60  
(C) 110  
(D) 120

46. Which of the following represents the equation of a straight line?

- (A)  $y = \frac{4}{x}$
- (B)  $y = x^2 - 4$
- (C)  $y = 2x + 3$
- (D)  $y = x^2 + 2x - 5$

Item 47 refers to the arrow diagram below

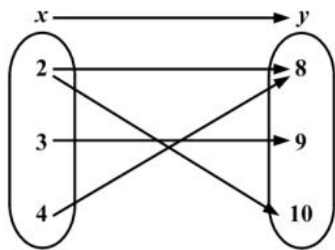

47. The arrow diagram above describes the relation

- (A)  $x$  is a factor of  $y$
- (B)  $x$  is less than  $y$
- (C)  $x$  is a multiple of  $y$
- (D)  $x$  is greater than  $y$

48. If  $f(x) = 2x^2 - 1$  then  $f(-3) =$

- (A) -32
- (B) -19
- (C) 17
- (D) 35

Item 49 refers to the diagram below.

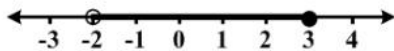

49. The graph of the inequality in the diagram above is defined by

- (A)  $-2 < x \leq 3$
- (B)  $-2 \leq x < 3$
- (C)  $-2 > x \geq 3$
- (D)  $-2 \geq x > 3$

50. What is the gradient of the straight line  $2y + 3x = -8$ ?

- (A) -3
- (B)  $-\frac{3}{2}$
- (C)  $\frac{2}{3}$
- (D) 3

51. Which of the following sets is represented by the relation  $f : x \rightarrow x^2 + 3$ ?

- (A)  $\{(0, 3), (1, 4), (2, 7), (3, 12)\}$
- (B)  $\{(0, 3), (1, 5), (2, 7), (3, 9)\}$
- (C)  $\{(0, 3), (1, 4), (2, 5), (3, 6)\}$
- (D)  $\{(0, 3), (1, 1), (2, 4), (3, 9)\}$

Item 52 refers to the diagram below of a construction. With centre  $A$ , an arc  $BC$  is drawn. With centre  $B$ , and the same radius, the arc  $PCQ$  is drawn.

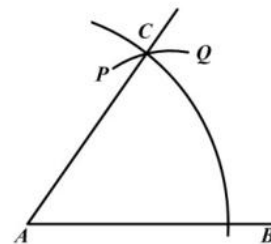

52. What is the measure of  $\angle BAC$ ?

- (A)  $30^\circ$
- (B)  $45^\circ$
- (C)  $60^\circ$
- (D)  $75^\circ$

Item 53 refers to the following diagram.

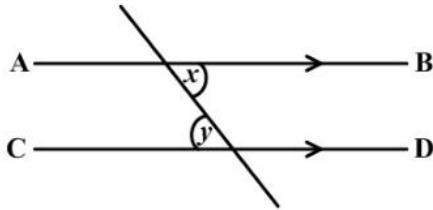

53. In the diagram,  $AB$  and  $CD$  are parallel. Which of the following BEST describes the relation between  $x$  and  $y$ ?

- (A)  $x = y$
- (B)  $x > y$
- (C)  $x + y > 2x$
- (D)  $x + y < 2x$

Item 54 refers to the diagram below.

54.  $AC$  and  $DE$  are straight lines intersecting at  $B$ . Angle  $DBA = 58^\circ$

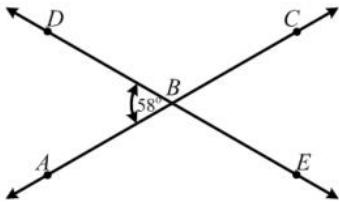

The measure of angle  $ABE$  is

- (A)  $58^\circ$
- (B)  $122^\circ$
- (C)  $142^\circ$
- (D)  $302^\circ$

Item 55 refers to the diagram below.

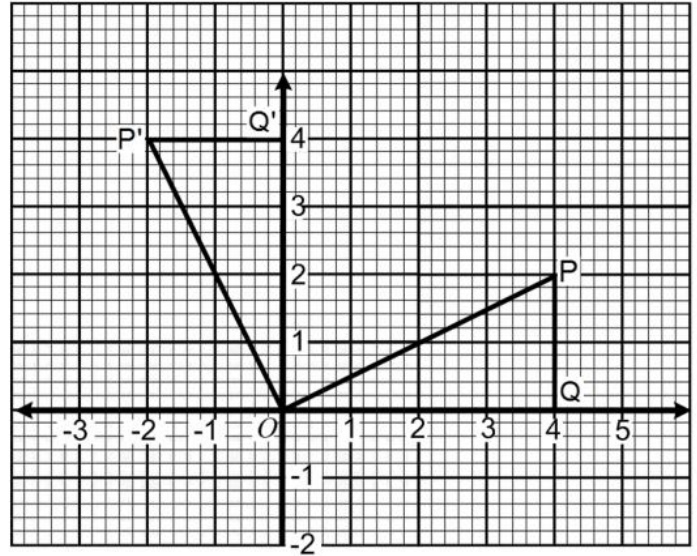

55. In the diagram above  $\triangle OPQ$  is mapped onto  $\triangle OP'Q'$ . What type of transformation has taken place?

- (A) Reflection
- (B) Enlargement
- (C) Translation
- (D) Rotation

56 In each of the diagrams shown below,  $A'$  is the image of  $A$ . Which of the diagrams shows a reflection in the  $x$ -axis?

(A)

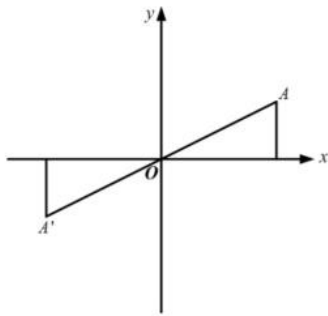

(B)

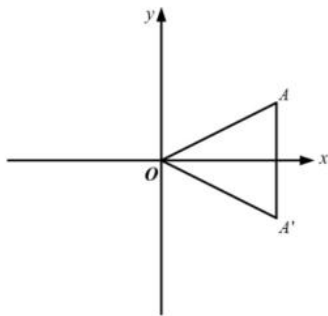

(C)

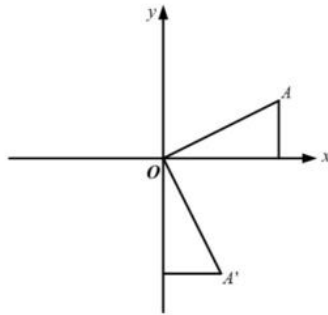

(D)

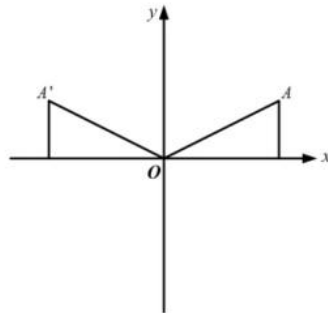

Item 57 refers to the diagram below.

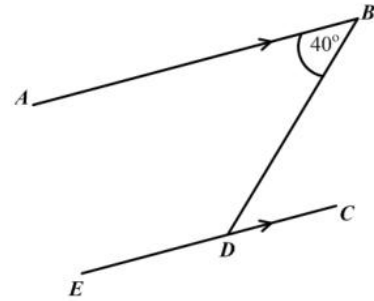

57.  $AB$  is parallel to  $EC$ . What is the measure of  $\angle BDE$ .

- (A)  $40^\circ$
- (B)  $50^\circ$
- (C)  $140^\circ$
- (D)  $180^\circ$

Item 58 refers to the triangle below.

58.

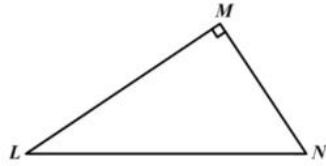

The triangle  $LMN$  is rotated in a clockwise direction about  $L$  through an angle of  $90^\circ$ . What is its image?

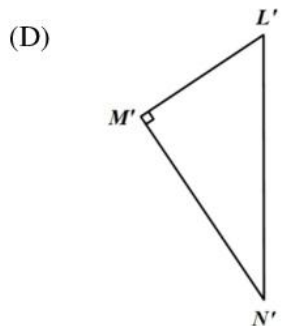
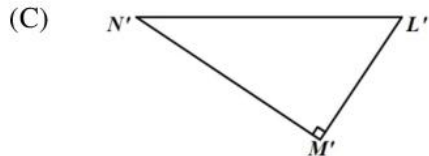
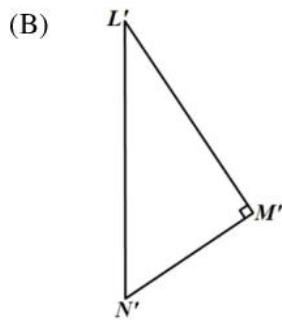
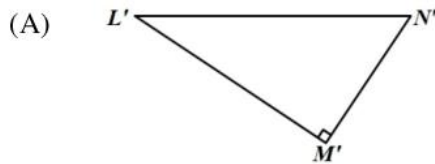

Item 59 refers to the diagram of the building below.

A boy stands 12 metres from the foot of the building and observes the angle of elevation of the top of the building.

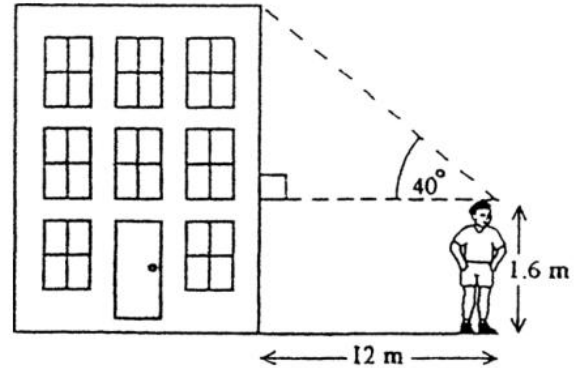

59. The height of the building is approximately

- (A)  $12 \tan 40^\circ$
- (B)  $1.6 + 12 \sin 40^\circ$
- (C)  $1.6 + 12 \cos 40^\circ$
- (D)  $1.6 + 12 \tan 40^\circ$

60. A ladder 5 metres long is leaning against a vertical wall. The foot of the ladder is 3 m away from the wall on horizontal ground. How far up the wall does the ladder reach?

- (A) 4 m
- (B) 6 m
- (C) 8 m
- (D) 15 m

**IF YOU FINISH BEFORE TIME IS CALLED, CHECK YOUR WORK ON THIS TEST.**

1. The number 3.14063 written correct to 3 decimal places is
- (A) 3.140  
(B) 3.141  
(C) 3.146  
(D) 3.150
2. Express 0.12 as a fraction in its lowest terms.
- (A)  $\frac{1}{9}$   
(B)  $\frac{3}{5}$   
(C)  $\frac{1}{8}$   
(D)  $\frac{3}{25}$
3. In scientific notation, 170.04 is written as
- (A)  $0.17004 \times 10^3$   
(B)  $1.7004 \times 10^2$   
(C)  $17.004 \times 10^1$   
(D)  $1.7004 \times 10^{-1}$
4. There are 40 students in a class. Girls make up 60% of the class. 25% of the girls wear glasses. How many girls in the class wear glasses?
- (A) 6  
(B) 8  
(C) 10  
(D) 15
5. If \$560 is shared in the ratio 2 : 3 : 9, then the difference between the largest and the smallest shares is
- (A) \$ 80  
(B) \$240  
(C) \$280  
(D) \$360
6. If 60% of a number is 90, what is the number?
- (A) 30  
(B) 54  
(C) 150  
(D) 180
7. The first three common multiples of 3, 4 and 6 are:
- (A) 12, 24, 36  
(B) 6, 8, 12  
(C) 3, 4, 6  
(D) 0, 1, 2
8. The number 301 can be written as
- (A)  $3 \times 10^2 + 1$   
(B)  $3 \times 10^3 + 1$   
(C)  $3 \times 10^2 + 1 \times 10$   
(D)  $3 \times 10^3 + 1 \times 10$
9. The value of the digit 5 in the number 537 is
- (A)  $\frac{5}{500}$   
(B) 50  
(C) 500  
(D) 5000
10. By the distributive law  $49 \times 17 + 49 \times 3 =$
- (A)  $52 + 66$   
(B)  $52 \times 66$   
(C)  $49 + 20$   
(D)  $49 \times 20$

GO ON TO THE NEXT PAGE

11. Which of the following sets is defined by  $\{x \in \mathbb{Z} : -2 \leq x \leq 4\}$ ?
- (A)  $\{0, 1, 2, 3, 4\}$   
 (B)  $\{1, 2, 3, 4\}$   
 (C)  $\{-1, 0, 1, 2, 3\}$   
 (D)  $\{-2, -1, 0, 1, 2, 3, 4\}$
12. In a class of 32 students, 17 study Music and 20 study Art. What is the LEAST number of students who are studying BOTH Music and Art?
- (A) 3  
 (B) 5  
 (C) 12  
 (D) 15
15. A dress which costs \$180 is being sold at a discount of 10%. The amount of the discount is
- (A) \$ 1.80  
 (B) \$ 10.00  
 (C) \$ 18.00  
 (D) \$170.00
16. A man's annual salary is \$45 000. His tax-free allowances total \$13 000. He has to pay a tax of 35% on his taxable income. The tax payable is
- (A) \$ 4 550.00  
 (B) \$11 200.00  
 (C) \$15 750.00  
 (D) \$20 300.00

Item 13 refers to the following information.

$P = \{\text{prime numbers}\}$

$Q = \{\text{odd numbers}\}$

$R = \{\text{even numbers}\}$

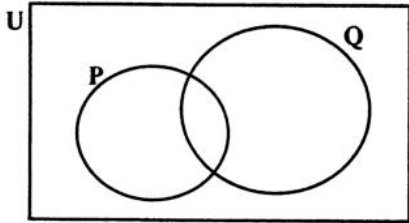
13. Which of the following sets is empty?
- (A)  $P \cap R$   
 (B)  $Q \cap R$   
 (C)  $P \cap Q$   
 (D)  $P \cup Q$
- Item 14 refers to the Venn diagram below.
- 
14. In the Venn diagram,  $n(P) = 5$ ,  $n(Q) = 9$  and  $n(P \cup Q) = 10$ . What is  $n(P \cap Q)$ ?
- (A) 4  
 (B) 6  
 (C) 14  
 (D) 24
17. If TT\$6.00 is equivalent to US\$1.00, then TT\$15.00 in U.S. dollars is
- (A) \$0.25  
 (B) \$0.40  
 (C) \$2.50  
 (D) \$4.00
18. If \$7000 is borrowed at the rate of 5% per annum for 3 years, the simple interest is
- (A) \$ 105  
 (B) \$ 210  
 (C) \$ 370  
 (D) \$1050
19. How much does a customer pay for an article marked at \$50.00 if a sales tax of 6% is charged?
- (A) \$44.00  
 (B) \$47.00  
 (C) \$53.00  
 (D) \$56.00

GO ON TO THE NEXT PAGE

20. Tracy bought a pen for \$60 and sold it to gain 20% on her cost price. How much money did she gain?
- (A) \$12  
(B) \$40  
(C) \$72  
(D) \$80
21. A salesman is paid 5% of his sales as commission. His sales for last month were \$2 020. How much commission was he paid?
- (A) \$ 11.00  
(B) \$ 20.20  
(C) \$101.00  
(D) \$110.00
22. A loan of \$8 000 was paid back in 2 years in monthly payments of \$400.00. The percentage interest on the loan was
- (A) 5%  
(B)  $8\frac{1}{3}\%$   
(C)  $16\frac{1}{3}\%$   
(D) 20%
23. If  $r * s = s^r$ , then  $3 * 2 =$
- (A) 8  
(B) 9  
(C) 12  
(D) 27
24.  $\frac{4}{5x} + \frac{2}{5x} =$
- (A)  $\frac{6}{25x}$   
(B)  $\frac{8}{25x}$   
(C)  $\frac{6}{10x}$   
(D)  $\frac{6}{5x}$
25.  $5(x + y) - 3(x - y) =$
- (A)  $2x$   
(B)  $2x + 2y$   
(C)  $2x + 8y$   
(D)  $8x + 8y$
26. If  $x = -2, y = 3, t = 2$ , then  $\left(\frac{x}{y}\right)^t =$
- (A)  $-\frac{4}{9}$   
(B)  $\frac{4}{9}$   
(C)  $\frac{4}{3}$   
(D)  $\frac{9}{4}$
27.  $3x^2 \times 2x^3 =$
- (A)  $6x^5$   
(B)  $5x^5$   
(C)  $5x^6$   
(D)  $72x^5$

GO ON TO THE NEXT PAGE

28. Given  $2x + 3 \geq 9$ , the range of values of  $x$  is

(A)  $x > 6$   
 (B)  $x \geq 6$   
 (C)  $x > 3$   
 (D)  $x \geq 3$

29. If  $5x - 26 = x + 50$ , then the value of  $x$  is

(A) -12  
 (B) -6  
 (C) 6  
 (D) 19

Item 30 refers to the following diagram.

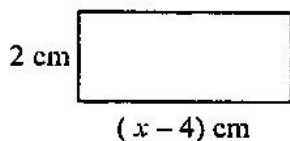

30. The area of the rectangle, in  $\text{cm}^2$ , is  $x^2$ . Which of the following equations may be used to find the value of  $x$ ?

(A)  $x^2 = 2(x - 4)$   
 (B)  $x^2 = (x - 2)(x - 4)$   
 (C)  $x^2 = 2(x - 4)(x - 2)$   
 (D)  $x^2 = (x - 4)(x + 2)$

31. If  $3 + \frac{2}{x} = 1$ , then the value of  $x$  is

(A) -1  
 (B)  $\frac{1}{5}$   
 (C)  $\frac{1}{2}$   
 (D) 5

Item 32 refers to the figure below.

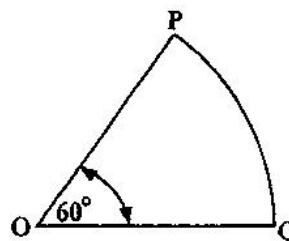

32. The figure above, **not drawn to scale**, shows a sector of a circle centre  $O$ . The length of the minor arc  $PQ$  is 8 cm. What would be the length of the circumference of the circle?

(A) 16 cm  
 (B) 24 cm  
 (C) 48 cm  
 (D) 64 cm

33. The volume of a cube whose edge is 6 cm long is

(A) 18  $\text{cm}^3$   
 (B) 36  $\text{cm}^3$   
 (C) 72  $\text{cm}^3$   
 (D) 216  $\text{cm}^3$

34. 2500 millimetres expressed in metres is

(A) 0.25  
 (B) 2.5  
 (C) 25  
 (D) 250

35. Tom leaves town  $P$  at 0600 hrs and drives to town  $Q$ , which is 595 km away. He arrives in town  $Q$  at 1300 hrs the same day. Tom's average speed was

(A) 70 km/h  
 (B) 75 km/h  
 (C) 85 km/h  
 (D) 90 km/h

GO ON TO THE NEXT PAGE

36. On leaving Trinidad, the time on a pilot's watch was 23:00 hrs. When he arrived at his destination, in the same time zone, on the following day his watch showed 03:00 hrs. How many hours did the flight take?

(A) 4  
 (B) 20  
 (C) 26  
 (D) 52

37. Fifty guests were each served 2 glasses of champagne. Each glass held 150 millilitres. How many litres of champagne were served?

(A) 0.15  
 (B) 1.5  
 (C) 15  
 (D) 150

38. Which of the figures below, **not drawn to scale**, has an area equal to  $\frac{1}{2}(3 + 4) \times 5$  square units?

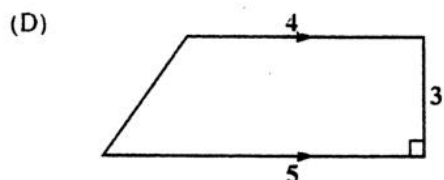
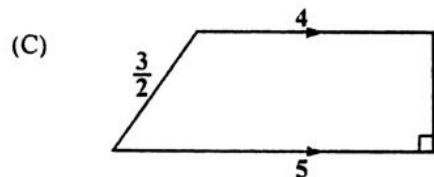
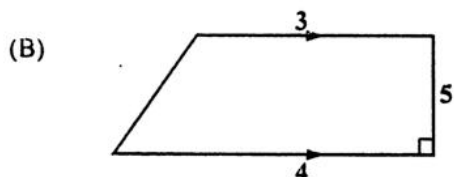
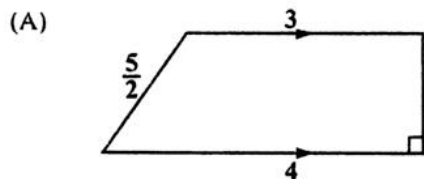

Item 39 refers to the diagram below.

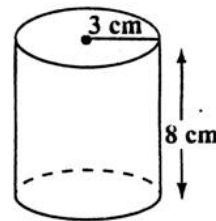

39. The diagram, **not drawn to scale**, shows a cylinder of radius 3 cm and height of 8 cm. The volume is

(A)  $12 \pi \text{ cm}^3$   
 (B)  $48 \pi \text{ cm}^3$   
 (C)  $72 \pi \text{ cm}^3$   
 (D)  $192 \pi \text{ cm}^3$

40. The area of a triangle is  $30 \text{ cm}^2$  and its base is 10 cm. What is the perpendicular height of the triangle?

(A) 6 cm  
 (B) 12 cm  
 (C) 13 cm  
 (D) 17 cm

41. The heights, in cm, of ten students are 150, 152, 153, 155, 155, 156, 158, 160, 165, 170. The **range** is

(A) 5  
 (B) 20  
 (C) 150  
 (D) 155

42. A bag contains 60 marbles of different colours but similar in size and mass. The probability of randomly choosing a red marble is  $\frac{5}{12}$ . How many red marbles does the bag contain?

(A) 5  
 (B) 12  
 (C) 17  
 (D) 25

GO ON TO THE NEXT PAGE

Item 43 refers to the following bar chart.

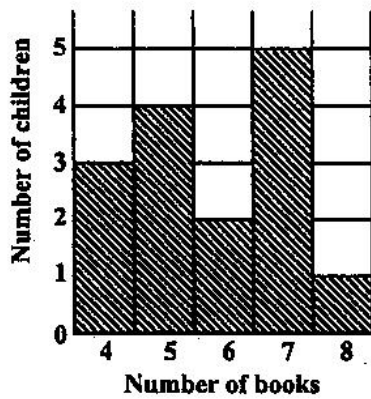

43. The bar chart above shows the number of books read by the children who took part in a survey.

How many children took part in the survey?

- (A) 5  
 (B) 15  
 (C) 75  
 (D) 87
44. If the mean of the four numbers 4, 8,  $x$  and 12 is 10, then  $x$  is
- (A) 4  
 (B) 10  
 (C) 12  
 (D) 16

Item 45 refers to the following diagram.

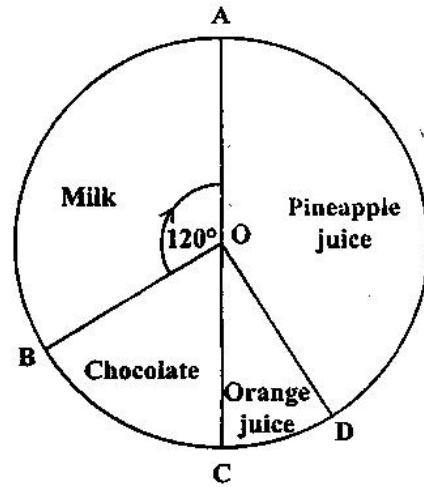

45. The pie-chart above shows the preference in drinks of a group of students. If 12 students prefer chocolate, then the TOTAL number of students is

- (A) 48  
 (B) 72  
 (C) 180  
 (D) 360

Item 46 refers to the graph below.

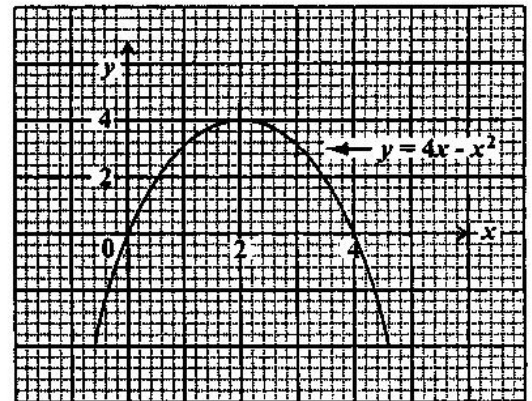

46. The maximum point of  $y = 4x - x^2$  is

- (A) (4, 2)  
 (B) (2, 4)  
 (C) (0, 4)  
 (D) (0, 0)

GO ON TO THE NEXT PAGE

Item 47 refers to the graph below.

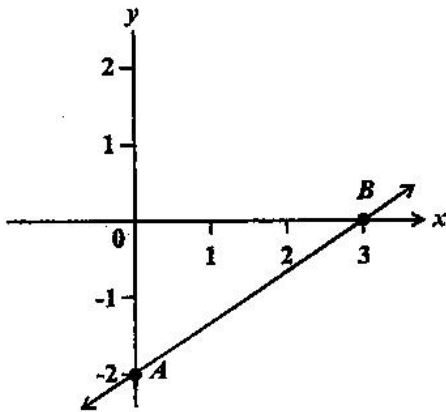

47. The straight line AB cuts the Y axis at
- (A) (0, 3)
  - (B) (0, 2)
  - (C) (3, -2)
  - (D) (0, -2)

48. Which of the following sets is represented by the relation  $f: x \rightarrow x^2 + 3$ ?
- (A)  $\{(0, 3), (1, 4), (2, 7), (3, 12)\}$
  - (B)  $\{(0, 3), (1, 5), (2, 7), (3, 9)\}$
  - (C)  $\{(0, 3), (1, 4), (2, 5), (3, 6)\}$
  - (D)  $\{(0, 3), (1, 1), (2, 4), (3, 9)\}$

Item 49 refers to the diagram below.

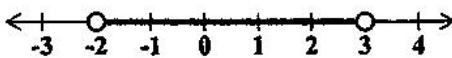

49. The inequality above is defined by
- (A)  $-2 \leq x < 3$
  - (B)  $-2 < x \leq 3$
  - (C)  $-2 \leq x \leq 3$
  - (D)  $-2 < x < 3$

50. If  $h(x) = \frac{3x-2}{5}$ , then  $h(-6) =$

- (A) -4
- (B)  $-\frac{16}{5}$
- (C)  $\frac{16}{5}$
- (D) 4

Item 51 refers to the arrow diagram below, which shows a function.

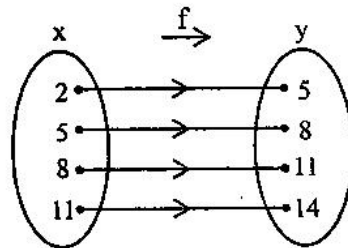

51. Which of the following BEST describes the function?
- (A)  $y = x$
  - (B)  $x = y + 3$
  - (C)  $f(x) = x + 3$
  - (D)  $f(x) = y + 3$
52. A boat was travelling on a bearing of  $270^\circ$ . In what direction was it travelling?
- (A) East
  - (B) West
  - (C) North
  - (D) South

53. If the sum of the interior angles of a polygon is 4 right angles, the polygon is a
- (A) triangle
  - (B) hexagon
  - (C) pentagon
  - (D) quadrilateral

GO ON TO THE NEXT PAGE

Item 54 refers to the diagram below of a construction. With centre A, an arc BC is drawn. With centre B, and the same radius, the arc PCQ is drawn.

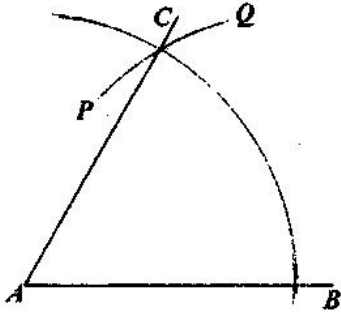

54. What is the measure of  $\angle BAC$ ?
- (A)  $30^\circ$
  - (B)  $45^\circ$
  - (C)  $60^\circ$
  - (D)  $75^\circ$

Item 55 refers to the following graph.

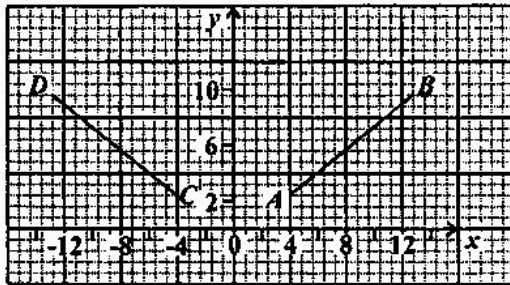

55. In the figure above, the line  $CD$  is the image of  $AB$  after
- (A) a rotation through  $90^\circ$  centre  $O$
  - (B) a reflection in the  $y$ -axis
  - (C) a translation by vector  $\begin{pmatrix} -4 \\ -8 \end{pmatrix}$
  - (D) an enlargement of scale factor  $-1$

Item 56 refers to the isosceles triangle below.

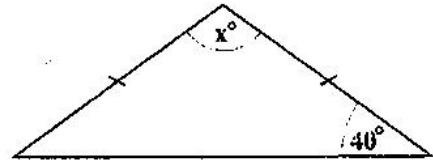

56. In the triangle, the value of  $x$  is
- (A)  $40^\circ$
  - (B)  $80^\circ$
  - (C)  $100^\circ$
  - (D)  $140^\circ$
57. The image of a point  $P(-2, 3)$  under a translation  $\begin{pmatrix} 3 \\ 4 \end{pmatrix}$  is
- (A)  $(-6, 12)$
  - (B)  $(-5, -1)$
  - (C)  $(5, 1)$
  - (D)  $(1, 7)$
58. A ladder 5 metres long is leaning against a vertical wall. The foot of the ladder is 3 metres away from the wall. How far up the wall does the ladder reach?
- (A) 4 m
  - (B) 6 m
  - (C) 8 m
  - (D) 15 m

GO ON TO THE NEXT PAGE

59. In a triangle ABC, angle  $A = x^\circ$  and angle  $B = 2x^\circ$ . What is the size of angle C?

- (A)  $45^\circ$
- (B)  $60^\circ$
- (C)  $\left(\frac{180}{3x}\right)^\circ$
- (D)  $(180 - 3x)^\circ$

Item 60 refers to the diagram of a building below.

A boy stands 12 metres from the foot of the building and observes the angle of elevation of the top of the building.

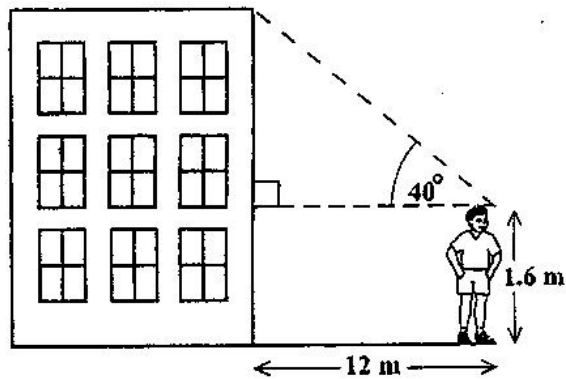

60. The height of the building is approximately

- (A)  $12 \tan 40^\circ$
- (B)  $1.6 + 12 \sin 40^\circ$
- (C)  $1.6 + 12 \cos 40^\circ$
- (D)  $1.6 + 12 \tan 40^\circ$

END OF TEST

IF YOU FINISH BEFORE TIME IS CALLED, CHECK YOUR WORK ON THIS TEST.

**CANDIDATE – PLEASE NOTE!**

PRINT your name on the line below and return this booklet with the answer sheet. Failure to do so may result in disqualification.

TEST CODE **01234010****FORM TP 2013091**

MAY/JUNE 2013

**CARIBBEAN SECONDARY EDUCATION CERTIFICATE®****SECONDARY EDUCATION CERTIFICATE****EXAMINATION****MATHEMATICS****Paper 01 – General Proficiency***1 hour 30 minutes***22 MAY 2013 (p.m.)****READ THE FOLLOWING INSTRUCTIONS CAREFULLY.**

1. This test consists of 60 items. You will have 1 hour and 30 minutes to answer them.
2. In addition to this test booklet, you should have an answer sheet.
3. **A list of formulae is provided on page 2 of this booklet.**
4. Each item in this test has four suggested answers, lettered (A), (B), (C), (D). Read each item you are about to answer, and decide which choice is best.
5. On your answer sheet, find the number which corresponds to your item and shade the space having the same letter as the answer you have chosen. Look at the sample item below.

Sample Item

$2a + 6a =$

- (A)  $8a$   
 (B)  $8a^2$   
 (C)  $12a$   
 (D)  $12a^2$

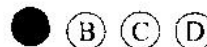
Sample Answer

The best answer to this item is “ $8a$ ”, so answer space (A) has been shaded.

6. If you want to change your answer, erase it completely before you fill in your new choice.
7. When you are told to begin, turn the page and work as quickly and as carefully as you can. If you cannot answer an item, go on to the next one. You may return to this item later. Your score will be the total number of correct answers.
8. You may do any rough work in the booklet.
9. Calculators and mathematical tables are NOT allowed for this paper.

---

**DO NOT TURN THIS PAGE UNTIL YOU ARE TOLD TO DO SO.**

---



## LIST OF FORMULAE

Volume of a prism	$V = Ah$ where $A$ is the area of a cross-section and $h$ is the perpendicular length.
Volume of cylinder	$V = \pi r^2 h$ where $r$ is the radius of the base and $h$ is the perpendicular height.
Volume of a right pyramid	$V = \frac{1}{3} Ah$ where $A$ is the area of the base and $h$ is the perpendicular height.
Circumference of a circle	$C = 2\pi r$ where $r$ is the radius of the circle.
Arc length	$S = \frac{\theta}{360} \times 2\pi r$ where $\theta^\circ$ is the angle subtended by the arc.
Area of a circle	$A = \pi r^2$ where $r$ is the radius of the circle.
Area of a sector of a circle	$A = \frac{\theta}{360} \times \pi r^2$ where $\theta^\circ$ is the angle in the sector.
Area of trapezium	$A = \frac{1}{2} (a + b) h$ where $a$ and $b$ are the lengths of the parallel sides and $h$ is the perpendicular distance between the parallel sides.

Roots of quadratic equations If  $ax^2 + bx + c = 0$ ,

$$\text{then } x = \frac{-b \pm \sqrt{b^2 - 4ac}}{2a}$$

Trigonometric ratios

$$\sin \theta = \frac{\text{opposite side}}{\text{hypotenuse}}$$

$$\cos \theta = \frac{\text{adjacent side}}{\text{hypotenuse}}$$

$$\tan \theta = \frac{\text{opposite side}}{\text{adjacent side}}$$

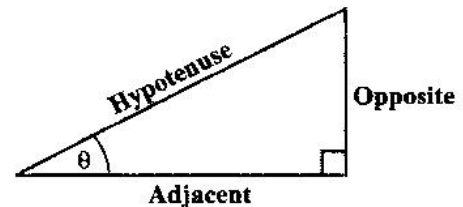

Area of triangle

Area of  $\triangle ABC = \frac{1}{2} bh$  where  $b$  is the length of the base and  $h$  is the perpendicular height

$$\text{Area of } \triangle ABC = \frac{1}{2} ab \sin C$$

$$\text{Area of } \triangle ABC = \sqrt{s(s-a)(s-b)(s-c)}$$

$$\text{where } s = \frac{a+b+c}{2}$$

Sine rule

$$\frac{a}{\sin A} = \frac{b}{\sin B} = \frac{c}{\sin C}$$

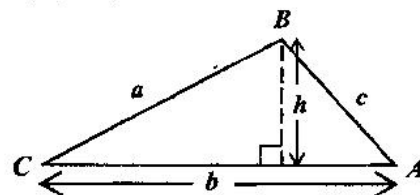

Cosine rule

$$a^2 = b^2 + c^2 - 2bc \cos A$$

GO ON TO THE NEXT PAGE

1.  $\left(\frac{2}{3}\right)^2$  is equal to
- (A)  $\frac{4}{6}$   
(B)  $\frac{4}{3}$   
(C)  $\frac{2}{9}$   
(D)  $\frac{4}{9}$
2. What percentage of 340 is 425?
- (A) 80%  
(B) 85%  
(C) 125%  
(D) 152%
3. Ann and Betty shared a sum of money in the ratio 2:3. Ann received \$120. What was Betty's share?
- (A) \$ 72  
(B) \$ 80  
(C) \$180  
(D) \$300
4. If  $12\frac{1}{2}\%$  of a sum of money is \$40, what is the TOTAL sum of money?
- (A) \$ 45  
(B) \$ 320  
(C) \$ 500  
(D) \$ 4 500
5. The value of  $29.94 \times 0.5$  is approximately
- (A) 0.15  
(B) 1.5  
(C) 15  
(D) 150
6. In a school, the ratio of the number of pupils to the number of teachers is 20 : 1. If the number of pupils is 840, how many teachers are there?
- (A) 40  
(B) 42  
(C) 800  
(D) 840
7. The LARGEST prime number that is less than 100 is
- (A) 91  
(B) 93  
(C) 97  
(D) 99
8. The H.C.F. of 12, 15 and 60 is
- (A) 1  
(B) 3  
(C) 12  
(D) 60
9. By the distributive law  $49 \times 17 + 49 \times 3 =$
- (A)  $52 + 66$   
(B)  $52 \times 66$   
(C)  $49 + 20$   
(D)  $49 \times 20$
10. The value of the digit 5 in the number 537 is
- (A) 5  
(B) 100  
(C) 500  
(D) 5 000
11. Which of the following sets is equivalent to  $\{a, b, c, d\}$ ?
- (A)  $\{4\}$   
(B)  $\{a, b, c\}$   
(C)  $\{p, q, r, s\}$   
(D)  $\{1, 2, 3, 4, 5\}$

GO ON TO THE NEXT PAGE

Item 12 refers to the Venn diagram below.

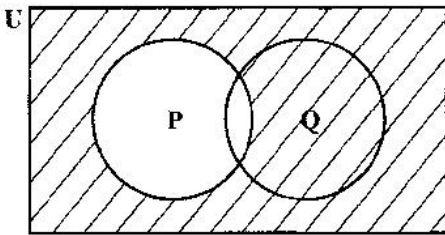

12. In the Venn diagram, the shaded area represents

- (A)  $P'$
- (B)  $(P \cup Q)'$
- (C)  $Q \cup P'$
- (D)  $Q \cap P'$

13. If  $X$  and  $Y$  are two finite sets such that  $n(X) = 7$ ,  $n(Y) = 5$  and  $n(X \cap Y) = 3$ , then  $n(X \cup Y)$  is

- (A) 6
- (B) 9
- (C) 15
- (D) 18

Item 14 refers to the Venn diagram below.

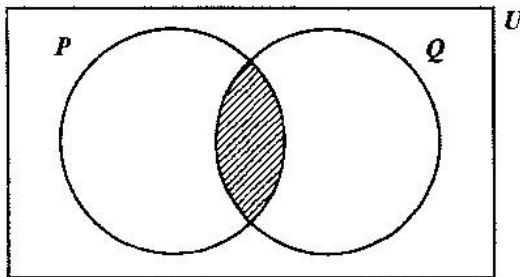

14. If  $P = \{\text{Factors of 6}\}$  and  $Q = \{\text{Factors of 4}\}$ , then the shaded region represents

- (A)  $\{ \}$
- (B)  $\{1, 2\}$
- (C)  $\{4, 6, 8, \dots\}$
- (D)  $\{12, 24, 36, \dots\}$

15. If TT\$6.00 is equivalent to US\$1.00, then TT\$15.00 in U.S. dollars is

- (A) \$0.25
- (B) \$0.40
- (C) \$2.50
- (D) \$4.00

16. A man's taxable income is S15 200. He pays tax at the rate of 25%. The amount of income tax he pays is

- (A) \$3 775
- (B) \$3 800
- (C) \$3 825
- (D) \$3 875

17. At the end of any year a car is worth 5% less than what it was worth at the beginning of the year. If a car was worth \$10 000 in January 2011, then its value in December 2011 was

- (A) \$9 995
- (B) \$9 500
- (C) \$9 025
- (D) \$9 000

18. Tom bought a pen for \$60 and sold it to gain 20% on his cost price. How much money did he gain?

- (A) \$12
- (B) \$40
- (C) \$72
- (D) \$80

19. Mr. Duncan bought a table at a discount of 30% thus saving \$42. What was the marked price of the table?

- (A) \$ 98
- (B) \$110
- (C) \$140
- (D) \$182

20. If the simple interest on \$800 for 3 years is \$54, what is the rate of interest per annum?
- (A)  $\frac{4}{9}\%$   
(B)  $2\frac{1}{4}\%$   
(C) 5%  
(D) 44%
21. At a sale, each book was marked \$3.00 off the original price. Daniel paid \$46.00 for two books that had the same sale price. What was the **original** cost of ONE of his books?
- (A) \$20.00  
(B) \$21.50  
(C) \$24.50  
(D) \$26.00
22. If \$7 000 is borrowed at the rate of 5% per annum for 3 years, the simple interest is
- (A) \$ 105  
(B) \$ 210  
(C) \$ 370  
(D) \$1 050
23. Seven times the product of two numbers,  $a$  and  $b$ , may be written as
- (A)  $7ab$   
(B)  $49ab$   
(C)  $7a + b$   
(D)  $7(a + b)$
24. If  $x$  is an integer that satisfies the inequality  $4 < 2x \leq 6$ , then
- (A)  $2 < x \leq 3$   
(B)  $-2 < x \leq 3$   
(C)  $-3 < x \leq 2$   
(D)  $-3 \leq x < -2$
25. If  $5(2x - 1) = 35$ , then  $x =$
- (A)  $-4$   
(B)  $\frac{1}{4}$   
(C) 3  
(D) 4
26.  $3x^2 \times 2x^3 =$
- (A)  $6x^5$   
(B)  $6x^6$   
(C)  $5x^6$   
(D)  $72x^5$
27. If  $x = 4$  and  $y = 2$ , what is the value of
- $$\frac{x^2 + 3y}{xy}$$
- (A)  $1\frac{3}{4}$   
(B)  $2\frac{1}{2}$   
(C)  $2\frac{3}{8}$   
(D)  $2\frac{3}{4}$
28. The sum of two positive numbers ( $p$  and  $q$ ) is 32. Their difference is 12. What is the **SMALLER** number?
- (A) 10  
(B) 12  
(C) 20  
(D) 22

29. When 6 is added to a number and the sum is divided by three, the result is four. This statement written in mathematical symbols is

(A)  $\frac{6+x}{3} = 4$

(B)  $\frac{6}{3} + x = 4$

(C)  $\frac{6+x}{3} = \frac{4}{3}$

(D)  $6 + \frac{x}{3} = 4$

30. The volume of a cube with edge 10 cm is

(A) 30 cm<sup>3</sup>

(B) 100 cm<sup>3</sup>

(C) 300 cm<sup>3</sup>

(D) 1 000 cm<sup>3</sup>

31. If  $3 + \frac{2}{x} = 1$ , then the value of  $x$  is

(A) -1

(B)  $\frac{1}{5}$

(C) 1

(D) 5

32. How many kilograms are there in one tonne?

(A) 10

(B) 100

(C) 1 000

(D) 10 000

Item 33 refers to the diagram below.

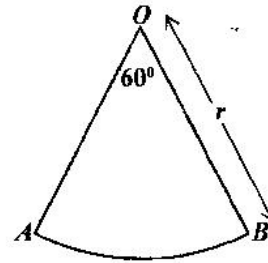

33.  $AOB$  is a sector of a circle such that angle  $AOB = 60^\circ$  and  $OB$  is  $r$  units long. The area of  $AOB$  is

(A)  $\frac{1}{6}\pi r^2$

(B)  $\frac{1}{6}\pi r$

(C)  $\frac{1}{3}\pi r^2$

(D)  $\frac{1}{3}\pi r$

Item 34 refers to the figure below which shows a triangle resting on a square.

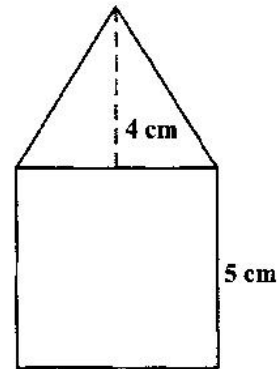

34. The length of one side of the square is 5 cm and the height of the triangle is 4 cm. What is the TOTAL area of the figure, in cm<sup>2</sup>?

(A) 35

(B) 45

(C) 50

(D) 100

GO ON TO THE NEXT PAGE

35. Which of the figures below, **not drawn to scale**, has an area equal to  $\frac{1}{2}(5+4) \times 2$  square units?

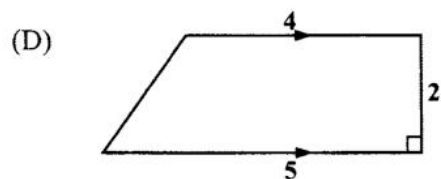
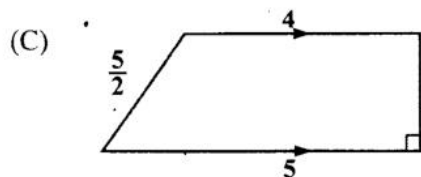
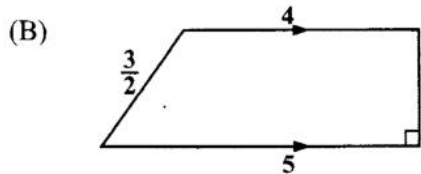
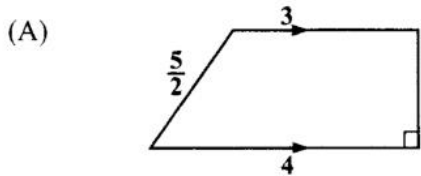

36. A car travels 80 kilometres in  $2\frac{1}{2}$  hours.  
What is its speed in kilometres per hour?

- (A) 6  
(B) 32  
(C) 82.5  
(D) 200

37. The area of a rectangle is  $53.6 \text{ cm}^2$ . If the length is multiplied by four and the width is halved, the area would then be
- (A)  $26.8 \text{ cm}^2$   
(B)  $53.6 \text{ cm}^2$   
(C)  $107.2 \text{ cm}^2$   
(D)  $214.4 \text{ cm}^2$

38. A man leaves home at 22:15 hrs and reaches his destination at 04:00 hrs on the following day, in the same time zone. How many hours did the journey take?

- (A) 5  
(B)  $5\frac{3}{4}$   
(C) 6  
(D)  $6\frac{1}{4}$

39. The perimeter of a square is 48 cm. What is the area, in  $\text{cm}^2$ ?

- (A) 36  
(B) 72  
(C) 108  
(D) 144

40. Among a group of employees, the highest paid receives a weekly wage of \$105.40. If the range of the wages is \$27.50, how much does the LOWEST paid employee receive?

- (A) \$ 27.50  
(B) \$ 66.45  
(C) \$ 77.90  
(D) \$105.40

Item 41 refers to the information below which shows the scores obtained by eleven footballers in a goal-shoot competition:

5, 3, 6, 8, 7, 8, 3, 11, 6, 3, 2

41. The modal score is

- (A) 3  
(B) 6  
(C) 8  
(D) 11

GO ON TO THE NEXT PAGE

42. A bag contains 2 red, 4 yellow and 6 blue marbles of similar size and shape. The probability of drawing a blue marble from the bag at random is

- (A)  $\frac{1}{6}$
- (B)  $\frac{1}{3}$
- (C)  $\frac{1}{2}$
- (D)  $\frac{6}{11}$

Item 43 refers to the bar chart below which shows the ages of children who took part in a survey.

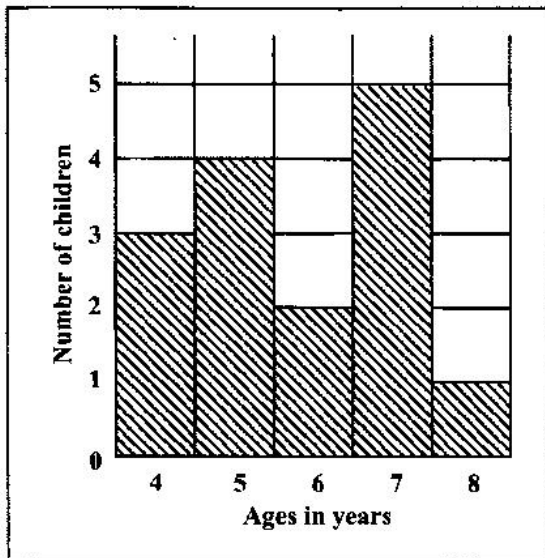

43. How many children took part in the survey?

- (A) 5
- (B) 15
- (C) 75
- (D) 87

Item 44 refers to the pie-chart below which shows the preference in drinks of a group of students.

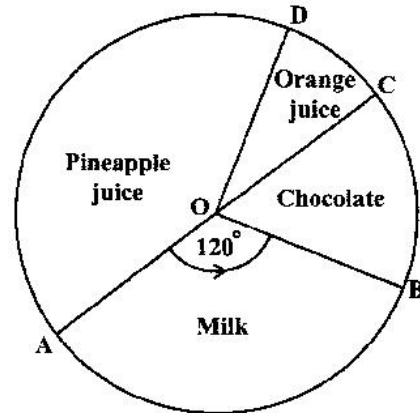

44. If 12 students prefer chocolate, then the TOTAL number of students is

- (A) 48
- (B) 72
- (C) 180
- (D) 360

45. Of 120 students writing an exam, 100 are expected to pass. The estimated probability that a randomly selected student will FAIL the exam is

- (A)  $\frac{1}{6}$
- (B)  $\frac{1}{5}$
- (C)  $\frac{1}{2}$
- (D)  $\frac{5}{6}$

46. Which of the following diagrams illustrates a function?

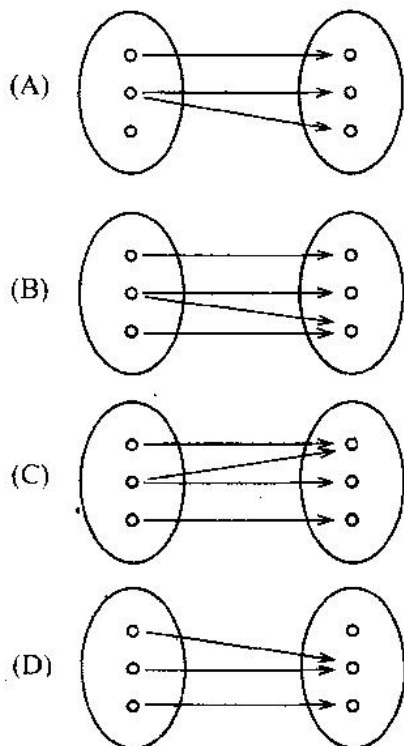

Item 47 refers to the diagram below.

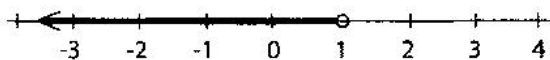

47. The graph of the inequality in the diagram is defined by

- (A)  $x < 1$
- (B)  $x > 1$
- (C)  $x \geq 1$
- (D)  $x \leq 1$

48. If  $f(x) = 2x^2 - 1$ , then  $f(-3) =$

- (A) -32
- (B) -19
- (C) 17
- (D) 35

Item 49 refers to the graph below.

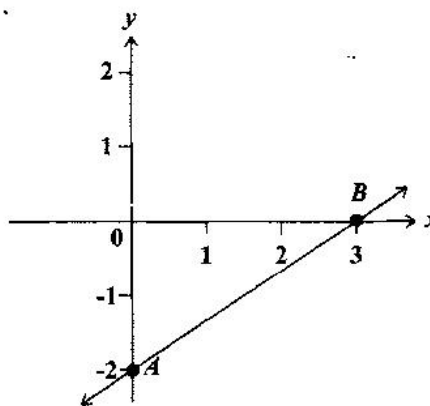

49. The straight line  $AB$  cuts the  $y$  axis at

- (A)  $(0, 3)$
- (B)  $(0, 2)$
- (C)  $(3, -2)$
- (D)  $(0, -2)$

50. What is the gradient of the straight line  $2y + 3x = -8$ ?

- (A) -3
- (B)  $-\frac{3}{2}$
- (C)  $\frac{2}{3}$
- (D) 3

Item 51 refers to the following diagram of a function.

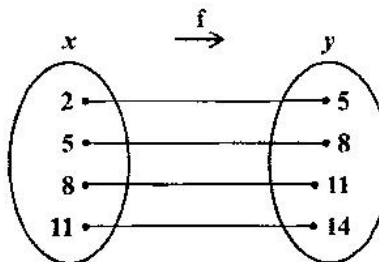

51. Which of the following statements BEST describes the function?

- (A)  $x = y + 3$
- (B)  $y = 2x + 1$
- (C)  $f(x) = 3 - x$
- (D)  $f(x) = x + 3$

GO ON TO THE NEXT PAGE

52. If the sum of the interior angles of a polygon is 4 right angles, then the polygon is a
- (A) triangle
  - (B) hexagon
  - (C) pentagon
  - (D) quadrilateral

Item 53 refers to the following diagram.

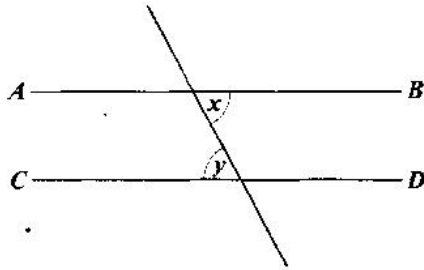

53. In the diagram  $AB$  and  $CD$  are parallel. Which of the following BEST describes the relation between  $x$  and  $y$ ?
- (A)  $x = y$
  - (B)  $x > y$
  - (C)  $x + y > 2x$
  - (D)  $x + y < 2x$

Item 54 refers to the triangle below.



54. In the triangle, the value of  $x$  is
- (A)  $30^\circ$
  - (B)  $60^\circ$
  - (C)  $120^\circ$
  - (D)  $150^\circ$
55. The image of the point  $P(-3, 2)$  under the translation  $\begin{pmatrix} 2 \\ 1 \end{pmatrix}$  is
- (A)  $(-5, 3)$
  - (B)  $(-2, 4)$
  - (C)  $(-1, 1)$
  - (D)  $(-1, 3)$

Item 56 refers to the following diagram.

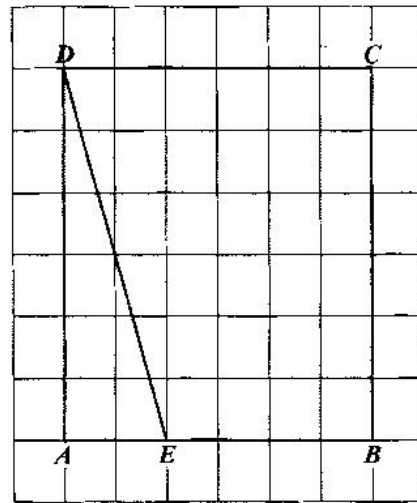

56. How many triangles congruent to  $\triangle ADE$  would be needed to cover the rectangle  $ABCD$  entirely?
- (A) 2
  - (B) 4
  - (C) 6
  - (D) 8

Item 57 refers to triangle  $ABC$  below.

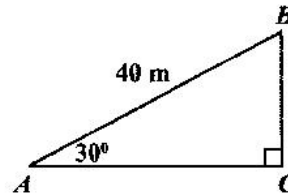

57. In the triangle, **not drawn to scale**, angle  $BAC = 30^\circ$  and  $AB = 40$  m. The length  $BC$ , in metres, is
- (A)  $40 \sin 30^\circ$
  - (B)  $40 \tan 30^\circ$
  - (C)  $40 \sin 60^\circ$
  - (D)  $40 \tan 60^\circ$

GO ON TO THE NEXT PAGE

Item 58 refers to the triangle  $LMN$  below.

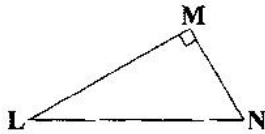

58. Triangle  $LMN$  is rotated in a clockwise direction about  $L$  through an angle of  $90^\circ$ . What is its image?

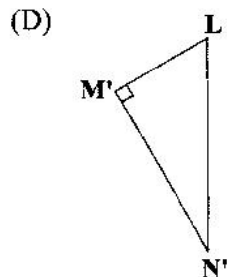
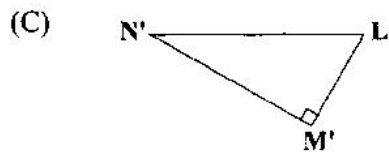
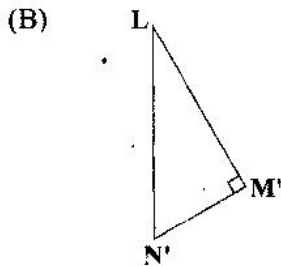
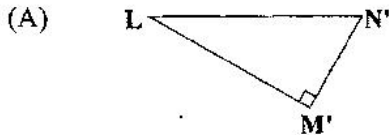

59. A plane is flying in a direction of  $045^\circ$  and changes course in a clockwise direction to  $135^\circ$ . The angle through which the plane turns is

- (A)  $45^\circ$   
 (B)  $90^\circ$   
 (C)  $135^\circ$   
 (D)  $270^\circ$

Item 60 refers to the following graph.

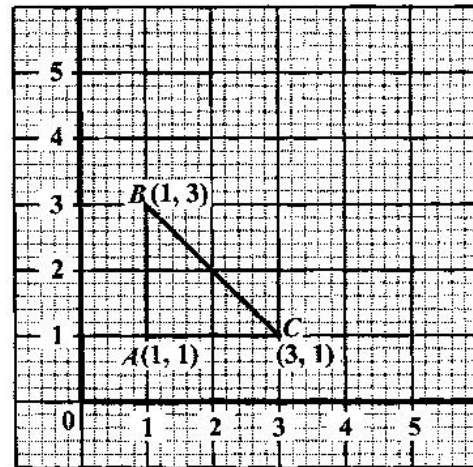

60.  $A'B'C'$  is the image of  $ABC$  under an enlargement of scale factor 2. The area of  $A'B'C'$ , in square units, is

- (A) 2  
 (B) 4  
 (C) 8  
 (D) 12

**END OF TEST**

**IF YOU FINISH BEFORE TIME IS CALLED, CHECK YOUR WORK ON THIS TEST.**

**CANDIDATE – PLEASE NOTE!**

PRINT your name on the line below and return this booklet with the answer sheet. Failure to do so may result in disqualification.

TEST CODE **01234010****FORM TP 2014088**

MAY/JUNE 2014

**CARIBBEAN EXAMINATIONS COUNCIL  
CARIBBEAN SECONDARY EDUCATION CERTIFICATE®  
EXAMINATION**

**MATHEMATICS****Paper 01 – General Proficiency***1 hour 30 minutes***21 MAY 2014 (p.m.)****READ THE FOLLOWING INSTRUCTIONS CAREFULLY.**

1. This test consists of 60 items. You will have 1 hour and 30 minutes to answer them.
2. In addition to this test booklet, you should have an answer sheet.
3. **A list of formulae is provided on page 2 of this booklet.**
4. Each item in this test has four suggested answers, lettered (A), (B), (C), (D). Read each item you are about to answer, and decide which choice is best.
5. On your answer sheet, find the number which corresponds to your item and shade the space having the same letter as the answer you have chosen. Look at the sample item below.

Sample Item

$2a + 6a =$

- (A)  $8a$   
 (B)  $8a^2$   
 (C)  $12a$   
 (D)  $12a^2$

Sample Answer

The correct answer to this item is “ $8a$ ”, so answer space (A) has been shaded.

6. If you want to change your answer, erase it completely before you fill in your new choice.
7. When you are told to begin, turn the page and work as quickly and as carefully as you can. If you cannot answer an item, go on to the next one. You may return to this item later. Your score will be the total number of correct answers.
8. You may do any rough work in the booklet.
9. Calculators and mathematical tables are NOT allowed for this paper.

**DO NOT TURN THIS PAGE UNTIL YOU ARE TOLD TO DO SO.**

**LIST OF FORMULAE**

Volume of a prism	$V = Ah$ where $A$ is the area of a cross-section and $h$ is the perpendicular length.
Volume of cylinder	$V = \pi r^2 h$ where $r$ is the radius of the base and $h$ is the perpendicular height.
Volume of a right pyramid	$V = \frac{1}{3} Ah$ where $A$ is the area of the base and $h$ is the perpendicular height.
Circumference	$C = 2\pi r$ where $r$ is the radius of the circle.
Arc length	$S = \frac{\theta}{360} \times 2\pi r$ where $\theta$ is the angle subtended by the arc, measured in degrees.
Area of a circle	$A = \pi r^2$ where $r$ is the radius of the circle.
Area of a sector	$A = \frac{\theta}{360} \times \pi r^2$ where $\theta$ is the angle of the sector, measured in degrees.
Area of trapezium	$A = \frac{1}{2} (a + b) h$ where $a$ and $b$ are the lengths of the parallel sides and $h$ is the perpendicular distance between the parallel sides.

Roots of quadratic equations If  $ax^2 + bx + c = 0$ ,  
 then  $x = \frac{-b \pm \sqrt{b^2 - 4ac}}{2a}$

Trigonometric ratios

$$\sin \theta = \frac{\text{opposite side}}{\text{hypotenuse}}$$

$$\cos \theta = \frac{\text{adjacent side}}{\text{hypotenuse}}$$

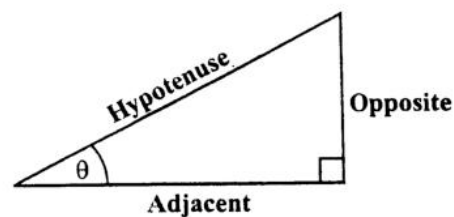
$$\tan \theta = \frac{\text{opposite side}}{\text{adjacent side}}$$

Area of triangle  
 Area of  $\triangle ABC = \frac{1}{2} bh$  where  $b$  is the length of the base and  $h$  is the perpendicular height.

$$\text{Area of } \triangle ABC = \frac{1}{2} ab \sin C$$

$$\text{Area of } \triangle ABC = \sqrt{s(s-a)(s-b)(s-c)}$$

where  $s = \frac{a+b+c}{2}$

$$\frac{a}{\sin A} = \frac{b}{\sin B} = \frac{c}{\sin C}$$

Sine rule

Cosine rule

$$a^2 = b^2 + c^2 - 2bc \cos A$$

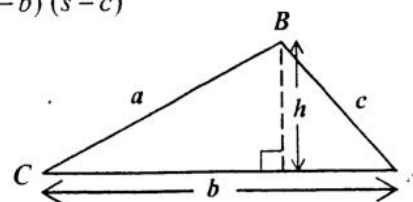

1. In standard form 0.0325 is written as
- (A)  $3.25 \times 10^{-3}$   
(B)  $3.25 \times 10^{-2}$   
(C)  $3.25 \times 10^{-1}$   
(D)  $3.25 \times 100$
2. Express 0.12 as a fraction in its lowest terms.
- (A)  $\frac{1}{9}$   
(B)  $\frac{3}{5}$   
(C)  $\frac{1}{8}$   
(D)  $\frac{3}{25}$
3. 540 beads are shared in the ratio 4:5. The LARGER share of beads is
- (A) 60  
(B) 240  
(C) 300  
(D) 432
4. If  $235 \times 48.7 = 11\,444.5$ , then  $23.5 \times 0.487 =$
- (A) 11.4445  
(B) 114.445  
(C) 1 144.45  
(D) 11 444.4
5.  $12\frac{1}{2}\%$  of a sum of money is \$40. What is the sum of money?
- (A) \$ 45  
(B) \$ 320  
(C) \$ 500  
(D) \$4 500
6. There are 40 students in a class. Girls make up 60% of the class. 25% of the girls wear glasses. How many girls in the class wear glasses?
- (A) 6  
(B) 8  
(C) 10  
(D) 15
7. The next term in the sequence 1, 6, 13, 22, 33 is
- (A) 44  
(B) 45  
(C) 46  
(D) 52
8. What is the value of the digit 2 in the number 48.621?
- (A)  $\frac{2}{100}$   
(B)  $\frac{2}{10}$   
(C) 2  
(D) 200
9. The square root of 181 lies between
- (A) 13 and 14  
(B) 45 and 46  
(C) 12 and 13  
(D) 11 and 13
10. By the distributive law  $49 \times 17 + 49 \times 3 =$
- (A)  $52 + 66$   
(B)  $52 \times 66$   
(C)  $49 + 20$   
(D)  $49 \times 20$

11. Which of the following sets is defined by  $\{x \in \mathbb{Z} : -2 \leq x \leq 4\}$  ?
- (A)  $\{0, 1, 2, 3, 4\}$   
 (B)  $\{1, 2, 3, 4\}$   
 (C)  $\{-1, 0, 1, 2, 3\}$   
 (D)  $\{-2, -1, 0, 1, 2, 3, 4\}$

Item 12 refers to the Venn diagram below.

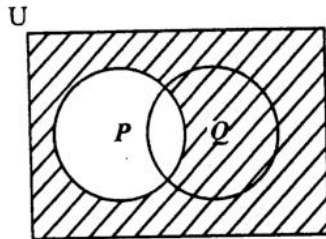

12. The shaded region represents
- (A)  $P'$   
 (B)  $(P \cup Q)$   
 (C)  $P \cup Q'$   
 (D)  $Q \cap P'$

Item 13 refers to the Venn diagram below.

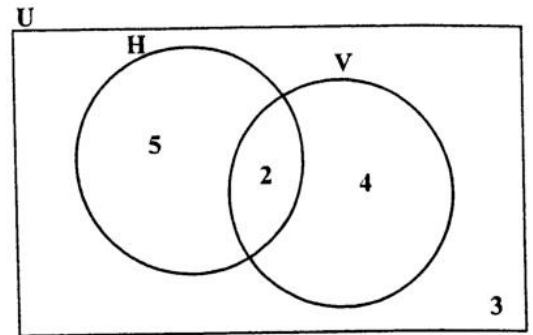

13. In the Venn diagram

$U = \{\text{students who play games}\}$   
 $H = \{\text{students who play hockey}\}$   
 $V = \{\text{students who play volleyball}\}$

The number of students in each set is indicated. How many students do NOT play volleyball?

- (A) 2  
 (B) 3  
 (C) 5  
 (D) 8
14. If  $Q = \{a, b, c\}$  how many subsets can be obtained from the set Q?
- (A)  $2 + 3$   
 (B)  $2 \times 3$   
 (C)  $3^2$   
 (D)  $2^3$
15. A dress which costs \$180 is being sold at a discount of 10%. The amount of the discount is
- (A) \$ 1.80  
 (B) \$ 10.00  
 (C) \$ 18.00  
 (D) \$170.00

16. An article bought for \$125 was sold for \$175. The profit as a percentage of the cost price was

(A) 28.6  
 (B) 40  
 (C) 50  
 (D) 71.4

17. If TT\$6.00 is equivalent to US\$1.00, then TT\$15.00 in US dollars is

(A) \$0.25  
 (B) \$0.40  
 (C) \$2.50  
 (D) \$4.00

18. A dinner at a restaurant was advertised at \$60 plus 18% tax. The total bill for this dinner was

(A) \$60.00  
 (B) \$70.80  
 (C) \$78.00  
 (D) \$81.60

Item 19 refers to toothpaste which is sold in tubes containing four different amounts.

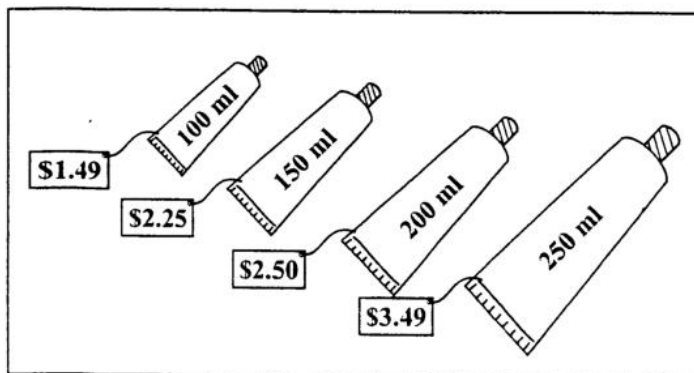

19. Which amount is the BEST buy?

(A) 100 ml  
 (B) 150 ml  
 (C) 200 ml  
 (D) 250 ml

20. Mary invested \$200 for 3 years at 5% per annum. John invested \$300 at the same rate. If they both received the same amount of money in simple interest, for how many years did John invest his money?

(A)  $1\frac{1}{2}$   
 (B) 2  
 (C) 3  
 (D) 10

21. A salesman is paid 5% of his sales as commission. His sales for last month were \$2 020. How much was he paid?

(A) \$ 11.00  
 (B) \$ 20.20  
 (C) \$101.00  
 (D) \$110.00

22. If the simple interest on \$900 for 3 years was \$108, what was the rate of interest?

(A) 3%  
 (B) 4%  
 (C) 12%  
 (D) 25%

23. If  $r * s = s^r$ , then  $3 * 2 =$

(A) 8  
 (B) 9  
 (C) 12  
 (D) 27

24.  $\frac{1}{5x} + \frac{2}{3x} =$
- (A)  $\frac{3}{8x^2}$
- (B)  $\frac{3}{8x}$
- (C)  $\frac{13}{15x^2}$
- (D)  $\frac{13}{15x}$
25. If  $\frac{p}{5} = 20$ , then  $p =$
- (A)  $20 - 5$
- (B)  $20 + 5$
- (C)  $20 \div 5$
- (D)  $20 \times 5$
26. If  $x = -2$ ,  $y = 3$ ,  $t = 2$ , then  $\left(\frac{x}{y}\right)^t =$
- (A)  $-\frac{4}{9}$
- (B)  $\frac{4}{9}$
- (C)  $\frac{4}{3}$
- (D)  $\frac{9}{4}$
27.  $(8a)^2 =$
- (A)  $16a$
- (B)  $64a$
- (C)  $16a^2$
- (D)  $64a^2$
28. If  $5(2x - 1) = 35$ , then  $x =$
- (A)  $-4$
- (B)  $\frac{1}{4}$
- (C)  $3$
- (D)  $4$
29. Given that  $2x + 3 \geq 9$ , the range of values of  $x$  is
- (A)  $x > 3$
- (B)  $x \geq 3$
- (C)  $x > 6$
- (D)  $x \geq 6$
30. If  $a = 3$  and  $ab = 6$ , then  $a^2 - b^2 =$
- (A)  $1$
- (B)  $2$
- (C)  $5$
- (D)  $13$
31. When 6 is added to a number and the sum is divided by three, the result is four. This statement written in mathematical symbols is
- (A)  $\frac{6+x}{3} = 4$
- (B)  $\frac{6}{3} + x = 4$
- (C)  $\frac{6+x}{3} = \frac{4}{3}$
- (D)  $6 + \frac{x}{3} = 4$

Item 32 refers to the figure below.

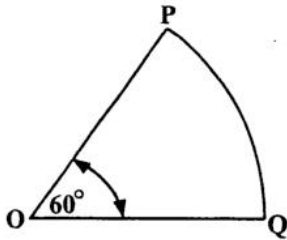

32. The figure above, **not drawn to scale**, shows a sector of a circle, centre O. The length of the minor arc PQ is 8 cm. What is the circumference of the circle?

- (A) 16 cm  
 (B) 24 cm  
 (C) 48 cm  
 (D) 64 cm

33. How many kilograms are there in one tonne?

- (A) 10  
 (B) 100  
 (C) 1 000  
 (D) 10 000

34. 2500 millimetres expressed in metres is

- (A) 0.25  
 (B) 2.5  
 (C) 25  
 (D) 250

35. The volume, in  $\text{cm}^3$ , of a cube of edge 3 cm is

- (A) 9  
 (B) 18  
 (C) 27  
 (D) 54

Item 36 refers to the diagrams below.

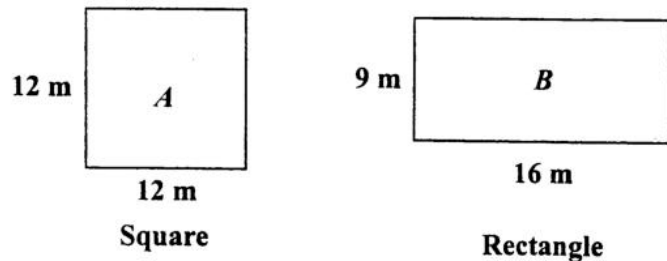

36. Which of the following statements is true about the perimeters of the figures A and B?

- (A) Perimeter of A = Perimeter of B  
 (B) Perimeter of A > Perimeter of B  
 (C) Perimeter of A  $\geq$  Perimeter of B  
 (D) Perimeter of A < Perimeter of B

37. A man started a journey at 09:30 h and arrived at his destination, in the same time zone, at 13:30 h on the same day. If his average speed was 30 km/h, then the distance, in km, for the journey was

- (A) 120  
 (B) 133  
 (C) 400  
 (D) 430

Item 38 refers to the diagram below.

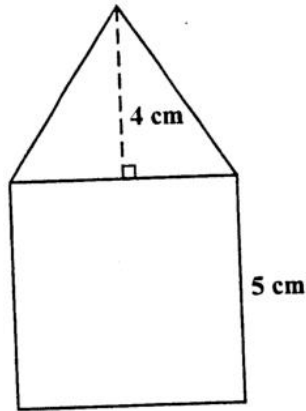

38. The figure above, **not drawn to scale**, consists of a triangle resting on a square of side 5 cm. The height of the triangle is 4 cm. What is the **TOTAL** area of the figure?

- (A) 35 cm<sup>2</sup>
- (B) 45 cm<sup>2</sup>
- (C) 50 cm<sup>2</sup>
- (D) 100 cm<sup>2</sup>

Item 39 refers to the diagram below.

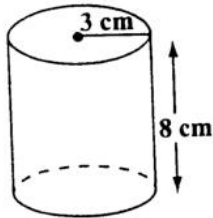

39. The diagram, **not drawn to scale**, shows a cylinder of radius 3 cm and height 8 cm. The volume is

- (A)  $12 \pi \text{ cm}^3$
- (B)  $48 \pi \text{ cm}^3$
- (C)  $72 \pi \text{ cm}^3$
- (D)  $192 \pi \text{ cm}^3$

40. On leaving Trinidad, the time on a pilot's watch was 23:00 h. When he arrived at his destination in the same time zone on the next day, his watch showed 03:00 h. How many hours did the flight take?

- (A) 4
- (B) 16
- (C) 20
- (D) 26

Item 41 refers to the following information.

4	7	10	18	18	27
---	---	----	----	----	----

41. The mode of the numbers is

- (A) 10
- (B) 14
- (C) 18
- (D) 27

Item 42 refers to the bar chart below.

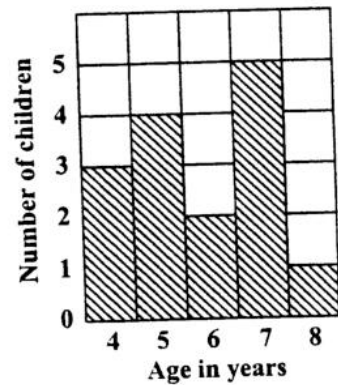

42. The bar chart shows the ages of children who took part in a survey.

How many children took part in the survey?

- (A) 5
- (B) 15
- (C) 75
- (D) 87

43. In a class of 20 students, 12 are girls. What is the probability that a student chosen at random is a boy?

- (A)  $\frac{1}{20}$   
(B)  $\frac{8}{20}$   
(C)  $\frac{12}{20}$   
(D)  $\frac{8}{12}$

44. The pie chart below, **drawn to scale**, shows how a student used 12 hours in studying English (E), Maths (M), French (F) and Geography (G).

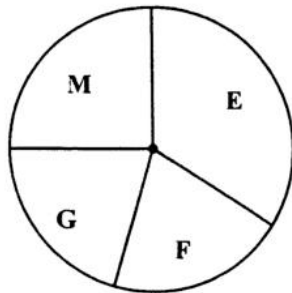

The amount of time spent studying Mathematics is APPROXIMATELY

- (A) 1 hour  
(B) 2 hours  
(C) 3 hours  
(D) 4 hours

45. Each of the letters of the word 'CHANCE' is written on a slip of paper similar in size and shape. The slips of paper are then placed in a bag and the bag thoroughly shaken. What is the probability of drawing a letter 'C'?

- (A)  $\frac{1}{3}$   
(B)  $\frac{1}{5}$   
(C)  $\frac{1}{6}$   
(D)  $\frac{2}{3}$

46. Which of the following represents the graph of a function?

(A)

(B)

(C)

(D)

Item 47 refers to the graph below.

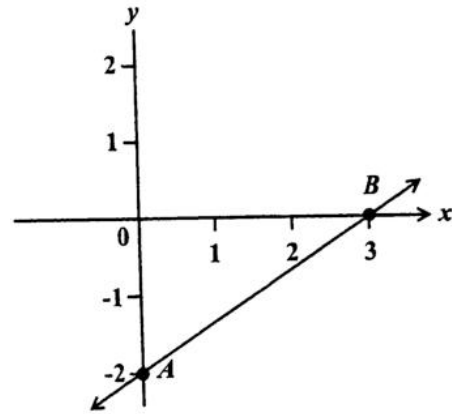

47. The straight line AB cuts the y axis at

- (A) (0, 3)
- (B) (0, 2)
- (C) (3, -2)
- (D) (0, -2)

Item 48 refers to the graph below.

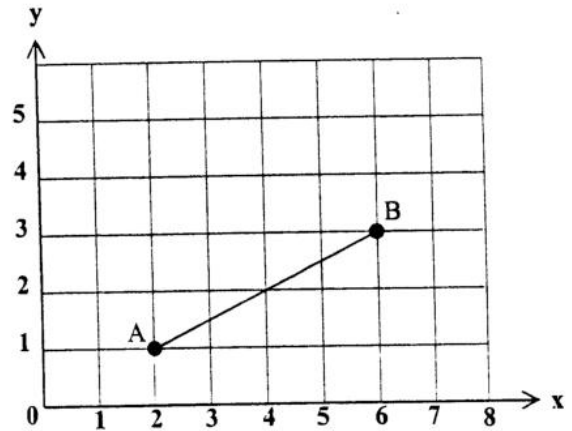

48. The gradient of AB in the graph above is

- (A) 2
- (B)  $\frac{1}{2}$
- (C)  $-\frac{1}{2}$
- (D) -2

Item 49 refers to the diagram below.

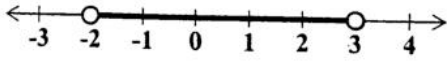

49. The inequality above is defined by

- (A)  $-2 \leq x < 3$
- (B)  $-2 < x \leq 3$
- (C)  $-2 \leq x \leq 3$
- (D)  $-2 < x < 3$

50. If  $f(x) = 2x^2 - 1$ , then  $f(3) =$

- (A) -32
- (B) -19
- (C) 17
- (D) 35

51. What is the gradient of the straight line  $2y = -3x - 8$ ?

- (A) -3
- (B)  $-\frac{3}{2}$
- (C) 2
- (D) 3

Item 52 refers to the diagram below of a construction.

With centre  $A$ , an arc  $BC$  is drawn. With centre  $B$ , and the same radius, the arc  $PCQ$  is drawn.

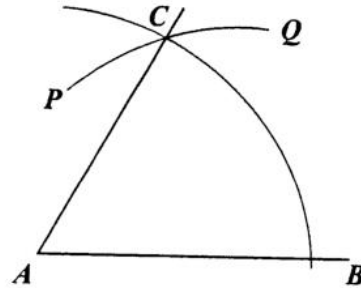

52. What is the measure of  $\angle BAC$ ?

- (A)  $30^\circ$
- (B)  $45^\circ$
- (C)  $60^\circ$
- (D)  $75^\circ$

Item 53 refers to the isosceles triangle below.

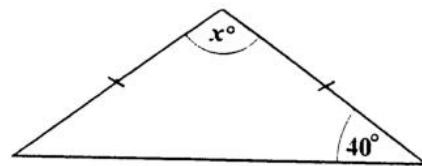

53. In the triangle, the value of  $x$  is

- (A) 40
- (B) 80
- (C) 100
- (D) 140

54. Which of the following statements BEST describes the properties of an equilateral triangle?

- I. All sides are equal.
- II. All angles are equal.
- III. Two sides are equal.
- IV. Two angles are equal.

- (A) I and II only
- (B) II and III only
- (C) III only
- (D) IV only

Item 55 refers to triangle  $ABC$  below.

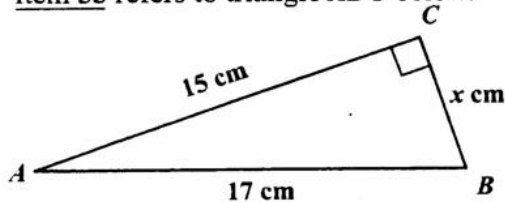

55. In the triangle  $ABC$ , not drawn to scale,  $AB$  is 17 cm,  $AC$  is 15 cm,  $BC$  is  $x$  cm and angle  $BCA$  is  $90^\circ$ . The value of  $x$  is

- (A) 7
- (B) 8
- (C) 9
- (D) 12

56. The image of a point  $P(-2, 3)$  under a

translation  $\begin{pmatrix} 3 \\ 4 \end{pmatrix}$  is

- (A)  $(-6, 12)$
- (B)  $(-5, -1)$
- (C)  $(5, 1)$
- (D)  $(1, 7)$

Item 57 refers to the diagram below.

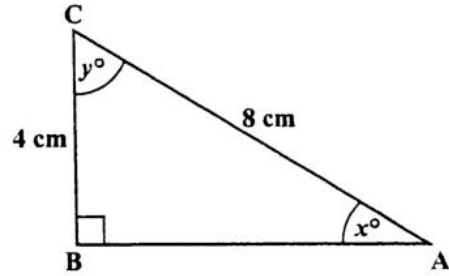

57. In the right-angled triangle above, which trigonometric ratio is equal to  $\frac{4}{8}$ ?

- (A)  $\sin x$
- (B)  $\tan y$
- (C)  $\cos x$
- (D)  $\tan x$

Item 58 refers to the following graph.

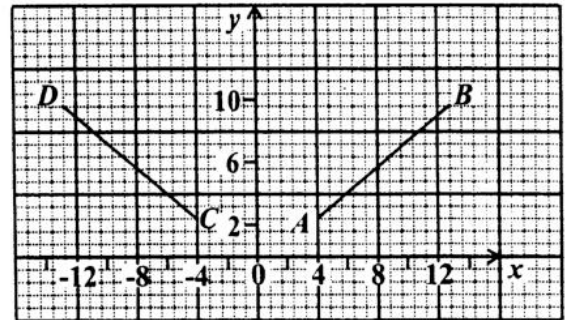

58. In the graph above, the line  $CD$  is the image of  $AB$  after

- (A) a rotation through  $90^\circ$  centre  $O$
- (B) a reflection in the  $y$ -axis
- (C) a translation by vector  $\begin{pmatrix} -4 \\ -8 \end{pmatrix}$
- (D) an enlargement of scale factor  $-1$

Item 59 refers to the diagram below.

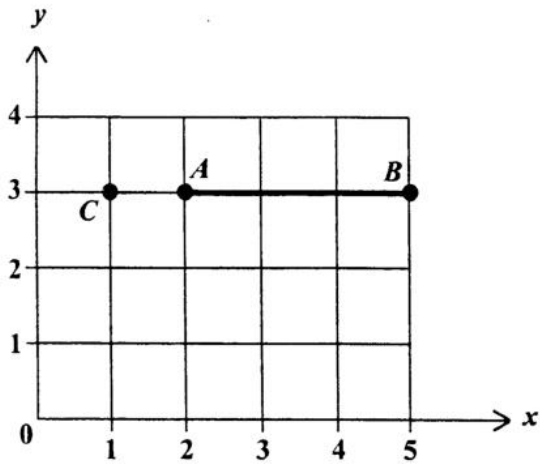

59. The line segment  $AB$  is rotated through  $90^\circ$  clockwise about the point  $C$ .

The coordinates of  $A'$ , the image of  $A$ , are

- (A) (1, 1)
- (B) (1, 2)
- (C) (1, 4)
- (D) (2, 2)

60. In a triangle  $ABC$ , angle  $A = x^\circ$  and angle  $B = 2x^\circ$ . What is the size of angle  $C$ ?

- (A)  $60^\circ$
- (B)  $45^\circ$
- (C)  $\left(\frac{180}{3x}\right)^\circ$
- (D)  $(180 - 3x)^\circ$

**END OF TEST**

**IF YOU FINISH BEFORE TIME IS CALLED, CHECK YOUR WORK ON THIS TEST.**



**CANDIDATE – PLEASE NOTE!**

PRINT your name on the line below and return this booklet with the answer sheet. Failure to do so may result in disqualification.

TEST CODE **01234010**

MAY/JUNE 2015

**FORM TP 2015088**

**CARIBBEAN SECONDARY EDUCATION CERTIFICATE®**  
**SECONDARY EDUCATION CERTIFICATE**  
**EXAMINATION**

**MATHEMATICS**

**Paper 01 – General Proficiency**

*1 hour 30 minutes*

**20 MAY 2015 (p.m.)**

**READ THE FOLLOWING INSTRUCTIONS CAREFULLY.**

1. This test consists of 60 items. You will have 1 hour and 30 minutes to answer them.
2. In addition to this booklet, you should have an answer sheet.
3. **A list of formulae is provided on page 2 of this booklet.**
4. Each item in this has four suggested answers lettered (A), (B), (C), (D). Read each item you are about to answer, and decide which choice is best.
5. On your answer sheet, find the number which corresponds to your item and shade the space having the same letter as the answer you have chosen. Look at the sample item below.

Sample Item

$$2a + 6a =$$

- (A)  $8a$   
 (B)  $8a^2$   
 (C)  $12a$   
 (D)  $12a^2$

Sample Answer

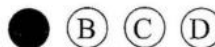

The best answer to this item is “8a”, so (A) has been shaded.

6. If you want to change your answer, erase it completely before you fill in your new choice.
7. When you are told to begin, turn the page and work as quickly and as carefully as you can. If you cannot answer an item, go on to the next one. You may return to that item later.
8. You may do any rough work in this booklet.
9. Calculators and mathematical tables are NOT allowed for this paper.

**DO NOT TURN THIS PAGE UNTIL YOU ARE TOLD TO DO SO.**



## LIST OF FORMULAE

Volume of a prism	$V = Ah$ where $A$ is the area of a cross-section and $h$ is the perpendicular length.
Volume of cylinder	$V = \pi r^2 h$ where $r$ is the radius of the base and $h$ is the perpendicular height.
Volume of a right pyramid	$V = \frac{1}{3} Ah$ where $A$ is the area of the base and $h$ is the perpendicular height.
Circumference of a circle	$C = 2\pi r$ where $r$ is the radius of the circle.
Arc length	$S = \frac{\theta}{360} \times 2\pi r$ where $\theta^\circ$ is the angle subtended by the arc.
Area of a circle	$A = \pi r^2$ where $r$ is the radius of the circle.
Area of a sector of a circle	$A = \frac{\theta}{360} \times \pi r^2$ where $\theta^\circ$ is the angle in the sector.
Area of trapezium	$A = \frac{1}{2} (a + b) h$ where $a$ and $b$ are the lengths of the parallel sides and $h$ is the perpendicular distance between the parallel sides.
Roots of quadratic equations	If $ax^2 + bx + c = 0$ ,

$$\text{then } x = \frac{-b \pm \sqrt{b^2 - 4ac}}{2a}$$

Trigonometric ratios

$$\sin \theta = \frac{\text{opposite side}}{\text{hypotenuse}}$$

$$\cos \theta = \frac{\text{adjacent side}}{\text{hypotenuse}}$$

$$\tan \theta = \frac{\text{opposite side}}{\text{adjacent side}}$$

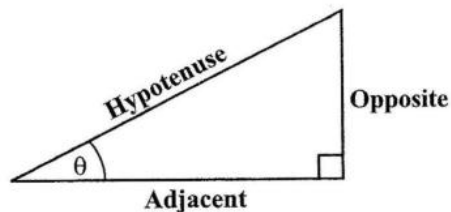

Area of triangle

Area of  $\triangle ABC = \frac{1}{2}bh$  where  $b$  is the length of the base and  $h$  is the perpendicular height

$$\text{Area of } \triangle ABC = \frac{1}{2}ab \sin C$$

$$\text{Area of } \triangle ABC = \sqrt{s(s-a)(s-b)(s-c)}$$

$$\text{where } s = \frac{a+b+c}{2}$$

$$\frac{a}{\sin A} = \frac{b}{\sin B} = \frac{c}{\sin C}$$

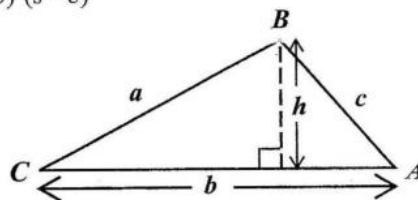

Sine rule

Cosine rule

$$a^2 = b^2 + c^2 - 2bc \cos A$$

GO ON TO THE NEXT PAGE

1.  $(-3)^2 + (-2)^2$  is equal to
- (A) -13  
(B) -10  
(C) 13  
(D) 25
2. What number when added to  $1\frac{1}{3}$  gives 2?
- (A)  $\frac{1}{3}$   
(B)  $\frac{2}{3}$   
(C) 1  
(D) 3
3. Ann and Betty shared a sum of money in the ratio 2:5. Ann received \$120. What was Betty's share?
- (A) \$ 72  
(B) \$ 80  
(C) \$180  
(D) \$300
4.  $11.1 \div 0.01$  is equal to
- (A) 110  
(B) 111  
(C) 1 100  
(D) 1 110
5. A test was marked out of 80. A boy scored 60% of the marks on the test. How many marks did he score?
- (A) 20  
(B) 48  
(C) 60  
(D) 75
6. If 30% of a number is 45, what is the number?
- (A) 30  
(B) 54  
(C) 150  
(D) 180
7. What is the value of the digit 6 in the number 48.061?
- (A)  $\frac{6}{100}$   
(B)  $\frac{6}{10}$   
(C) 6  
(D) 600
8. The H.C.F. of 12, 15 and 60 is
- (A) 1  
(B) 3  
(C) 12  
(D) 60
9. Using the distributive property  $49 \times 17 + 49 \times 3 =$
- (A)  $49 \times 20$   
(B)  $49 + 20$   
(C)  $52 \times 66$   
(D)  $52 + 66$
10. The next term in the sequence 1, 6, 13, 22, 33, \_\_\_\_\_, ... is
- (A) 44  
(B) 45  
(C) 46  
(D) 52
11. Given that  $P = \{2, 3, 5, 6\}$  and  $Q = \{2, 3, 4\}$  then  $P \cup Q$  is described as
- (A)  $\{x: 1 \leq x < 7; x \in N\}$   
(B)  $\{x: 1 < x < 7; x \in N\}$   
(C)  $\{x: 2 \leq x < 6; x \in N\}$   
(D)  $\{x: 2 < x < 6; x \in N\}$

GO ON TO THE NEXT PAGE

Item 12 refers to the Venn diagram below.

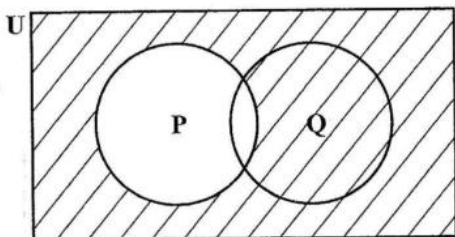

12. In the Venn diagram, the shaded area represents

(A)  $P'$   
 (B)  $(P \cup Q)'$   
 (C)  $Q \cup P'$   
 (D)  $Q \cap P'$

13. In a group of 40 students, 28 play tennis and 22 play chess. What is the LEAST number of students who play BOTH tennis and chess?

(A) 6  
 (B) 10  
 (C) 12  
 (D) 18

Item 14 refers to the Venn diagram below.

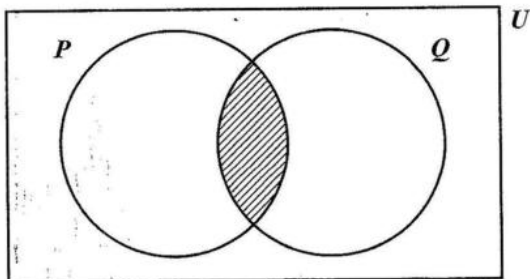

14. If  $P = \{\text{Factors of 6}\}$  and  $Q = \{\text{Factors of 4}\}$ , then the shaded region represents

(A)  $\{ \}$   
 (B)  $\{1, 2\}$   
 (C)  $\{4, 6, 8, \dots\}$   
 (D)  $\{12, 24, 36, \dots\}$

15. Mrs Jones' taxable income is \$18 400. She pays tax at a rate of 20%. The amount of income tax she pays is

(A) \$9 200  
 (B) \$4 600  
 (C) \$3 680  
 (D) \$1 472

16. The value of a plot of land is \$18 000. Land tax is charged at the rate of \$0.70 per \$100 value. What is the TOTAL amount of tax paid for the land?

(A) \$110.00  
 (B) \$126.00  
 (C) \$180.70  
 (D) \$257.15

17. At the end of any year a car is worth 5% less than what it was worth at the beginning of the year. If a certain car was worth \$10 000 at the beginning of 2014, then its value at the end of 2014 was

(A) \$9 995  
 (B) \$9 500  
 (C) \$9 025  
 (D) \$9 000

18. A man bought a mobile phone for \$800 and sold it for \$1 000. What was his profit as a percentage of the cost price?

(A) 5 %  
 (B) 15 %  
 (C) 20 %  
 (D) 25 %

19. Susan bought a calculator for \$120. She had to pay sales tax of 10% on the price. How much change would she receive from \$140?

(A) \$ 8  
 (B) \$12  
 (C) \$28  
 (D) \$32

GO ON TO THE NEXT PAGE

20. The simple interest on a loan of \$6 000 for 3 years was \$900. What was the rate of interest per annum?

(A) 2%  
 (B) 3%  
 (C) 5%  
 (D) 18%

21. A dress which costs \$180 is being sold at a discount of 10%. The amount of the discount is

(A) \$ 1.80  
 (B) \$ 10.00  
 (C) \$ 18.00  
 (D) \$170.00

22. If \$7 000 is borrowed at the rate of 5% per annum for 3 years, the simple interest is

(A) \$ 105  
 (B) \$ 210  
 (C) \$ 370  
 (D) \$1 050

23.  $-2(x - 4) =$

(A)  $-2x + 8$   
 (B)  $-2x + 4$   
 (C)  $-2x - 4$   
 (D)  $-2x - 8$

24. If  $x$  is an integer that satisfies the inequality  $4 < 2x \leq 6$ , then

(A)  $2 < x \leq 3$   
 (B)  $-2 < x \leq 3$   
 (C)  $-3 < x \leq 2$   
 (D)  $-3 \leq x < -2$

Item 25 refers to the information below which shows the cost of a pen and a box.

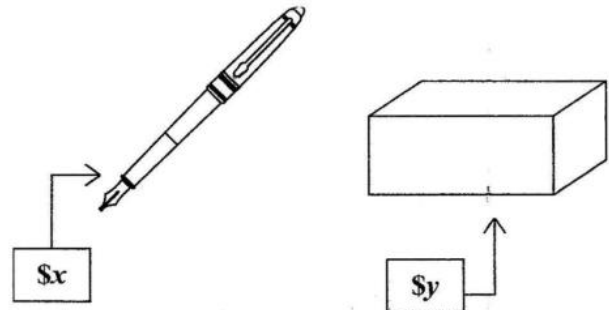

25. The total cost of 3 pens and 2 boxes is

(A)  $5xy$   
 (B)  $5(x + y)$   
 (C)  $2x + 3y$   
 (D)  $3x + 2y$

26.  $3x^2 \times 2x^3 =$

(A)  $6x^5$   
 (B)  $6x^6$   
 (C)  $5x^6$   
 (D)  $72x^5$

27.  $P = \frac{m^2}{2-m}$ . When  $m = -3$ , the value of  $P$  is

(A)  $-6$   
 (B)  $\frac{-6}{5}$   
 (C)  $\frac{9}{5}$   
 (D)  $9$

28. If  $a * b = \frac{b}{a} - 1$ , then  $7 * 28 =$

(A)  $-\frac{3}{4}$   
 (B)  $\frac{1}{4}$   
 (C)  $3$   
 (D)  $4$

GO ON TO THE NEXT PAGE

50, then the value of  $x$  is

- (A) -12  
 (B) -6  
 (C) 6  
 (D) 19

30. John has  $x$  marbles and Max has twice as many. Max gives John 5 of his marbles. How many marbles does Max now have?

- (A)  $x + 5$   
 (B)  $x - 5$   
 (C)  $2x - 5$   
 (D)  $2x + 5$

31. When 8 is subtracted from a certain number and the result is multiplied by 3 the answer is 21. What is the **original** number?

- (A) 1  
 (B) 3  
 (C) 10  
 (D) 15

32. The volume of a cube with edge 10 cm is

- (A)  $30 \text{ cm}^3$   
 (B)  $100 \text{ cm}^3$   
 (C)  $300 \text{ cm}^3$   
 (D)  $1\,000 \text{ cm}^3$

33. A car travels 80 kilometres in  $2\frac{1}{2}$  hours. What is its speed in kilometres per hour?

- (A) 6.5  
 (B) 32.0  
 (C) 82.5  
 (D) 200.0

34. Given that 1 millimetre =  $\frac{1}{1000}$  metres, express 2 500 millimetres in metres.

- (A) 0.25  
 (B) 2.5  
 (C) 25  
 (D) 250

Item 35 refers to the diagram below.

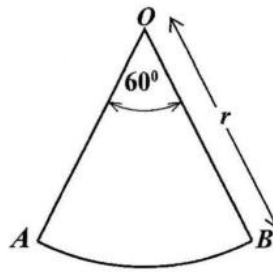

35.  $AOB$  is a sector of a circle such that angle  $AOB = 60^\circ$  and  $OB$  is  $r$  units long. The area of  $AOB$  is

- (A)  $\frac{1}{6}\pi r^2$   
 (B)  $\frac{1}{6}\pi r$   
 (C)  $\frac{1}{3}\pi r^2$   
 (D)  $\frac{1}{3}\pi r$

36. The distance around the edge of a circular pond is 88 metres. The radius, in metres, is

- (A)  $88\pi$   
 (B)  $176\pi$   
 (C)  $\frac{88}{\pi}$   
 (D)  $\frac{88}{2\pi}$

37. A man leaves home at 22:15 hours and reaches his destination at 04:00 hours on the following day in the same time zone. How many hours did the journey take?

- (A) 5  
 (B)  $5\frac{3}{4}$   
 (C) 6  
 (D)  $6\frac{1}{4}$

GO ON TO THE NEXT PAGE

38. The area of a triangle is  $30 \text{ cm}^2$  and its base is  $10 \text{ cm}$ . What is the height, in  $\text{cm}$ , of the triangle?

(A) 6  
 (B) 12  
 (C) 13  
 (D) 17

39. The perimeter of a square is  $48 \text{ cm}$ . What is the area, in  $\text{cm}^2$ ?

(A) 36  
 (B) 72  
 (C) 108  
 (D) 144

Item 40 refers to the diagram below.

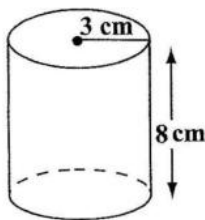

40. The diagram, **not drawn to scale**, shows a cylinder of radius  $3 \text{ cm}$  and height  $8 \text{ cm}$ . The volume is

(A)  $12 \pi \text{ cm}^3$   
 (B)  $48 \pi \text{ cm}^3$   
 (C)  $72 \pi \text{ cm}^3$   
 (D)  $192 \pi \text{ cm}^3$

Items 41–42 refer to the histogram below which shows the number of children aged 4, 5, 6, 7 and 8 who took part in a survey.

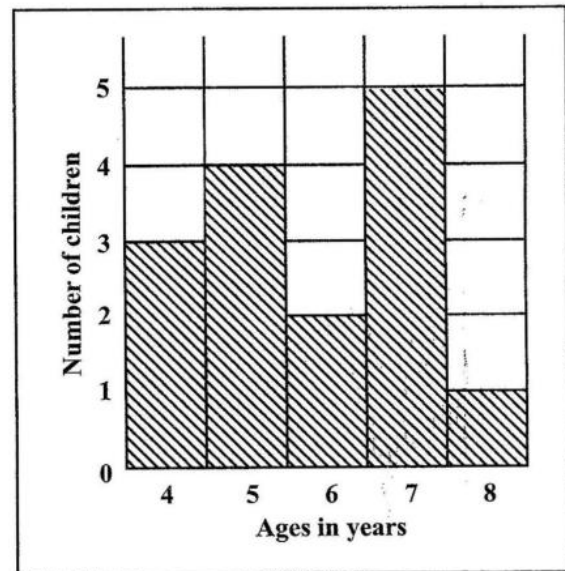

41. What was the modal age?

(A) 5  
 (B) 6  
 (C) 7  
 (D) 8

42. How many children took part in the survey?

(A) 5  
 (B) 15  
 (C) 75  
 (D) 87

GO ON TO THE NEXT PAGE

43. Jade's scores on her nine spelling tests are 5, 7, 7, 4, 5, 4, 7, 6, 6. Therefore, her median score on these nine tests is

- (A) 4
- (B) 5
- (C) 6
- (D) 7

44. If the mean of the four numbers 4, 8,  $x$  and 12 is 10, then  $x$  is

- (A) 4
- (B) 10
- (C) 12
- (D) 16

45. The boundaries of the class interval 10–14 are BEST recorded as

- (A)  $10 \leq x \leq 14$
- (B)  $9.5 < x < 14$
- (C)  $9.5 \leq x < 14.5$
- (D)  $10 \leq x \leq 14.5$

Item 46 refers to the graph below.

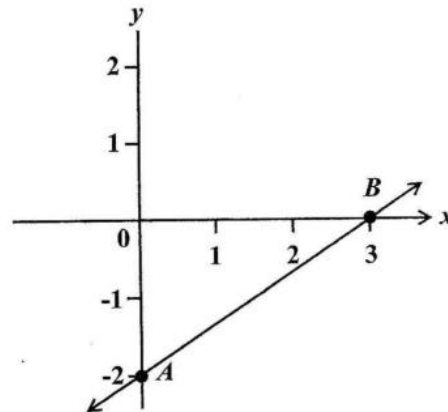

46. The straight line AB cuts the  $x$ -axis at

- (A) (3, 0)
- (B) (-2, 0)
- (C) (0, 3)
- (D) (0, -2)

Item 47 refers to the diagram below.

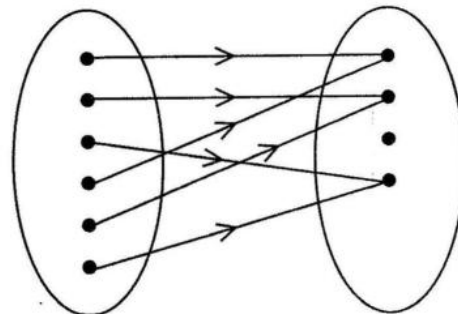

47. The relationship that BEST describes the mapping shown in the diagram is

- (A) one-to-one
- (B) many-to-one
- (C) one-to-many
- (D) many-to-many

48. If  $f(x) = 2x^2 - 1$ , then  $f(-3) =$

- (A) -32
- (B) -19
- (C) 17
- (D) 35

GO ON TO THE NEXT PAGE

Items 49–50 refer to the graph below.

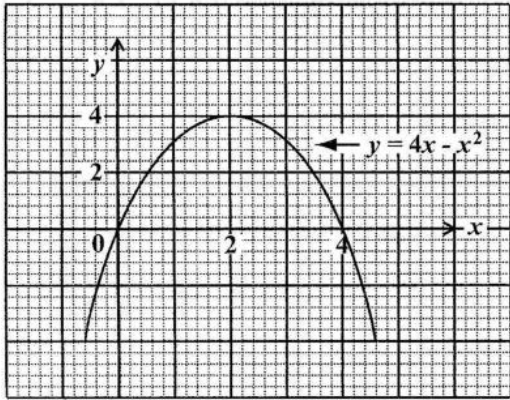

49. The maximum point of  $y = 4x - x^2$  is
- (A) (0, 0)
  - (B) (0, 4)
  - (C) (4, 2)
  - (D) (2, 4)
50. The values of  $x$  at the points where  $y = 4x - x^2$  intersects  $y = 0$  are
- (A)  $x = 0$  and  $x = 4$
  - (B)  $x = 0$  and  $x = 2$
  - (C)  $x = 0$  and  $x = -4$
  - (D)  $x = 2$  and  $x = 4$

Item 51 refers to the arrow diagram below, which shows a function.

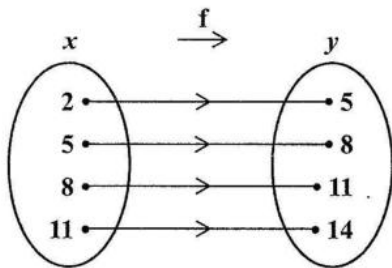

51. Which of the following BEST describes the function?
- (A)  $f(x) = x + 3$
  - (B)  $f(x) = y + 3$
  - (C)  $x = y + 3$
  - (D)  $y = x$

52. If the sum of the interior angles of a polygon is 4 right angles, then the polygon is a
- (A) triangle
  - (B) hexagon
  - (C) pentagon
  - (D) quadrilateral

Item 53 refers to the following diagram.

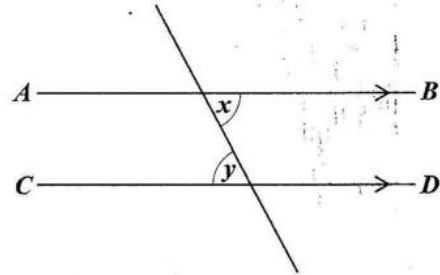

53. In the diagram,  $AB$  and  $CD$  are parallel. Which of the following BEST describes the relation between  $x$  and  $y$ ?
- (A)  $x + y < 2x$
  - (B)  $x = y$
  - (C)  $x + y > 2x$
  - (D)  $x > y$

Item 54 refers to the triangle below.

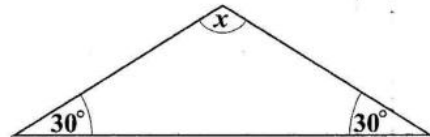

54. In the triangle, the value of  $x$  is
- (A)  $30^\circ$
  - (B)  $60^\circ$
  - (C)  $120^\circ$
  - (D)  $150^\circ$

Item 55 refers to the diagram below.

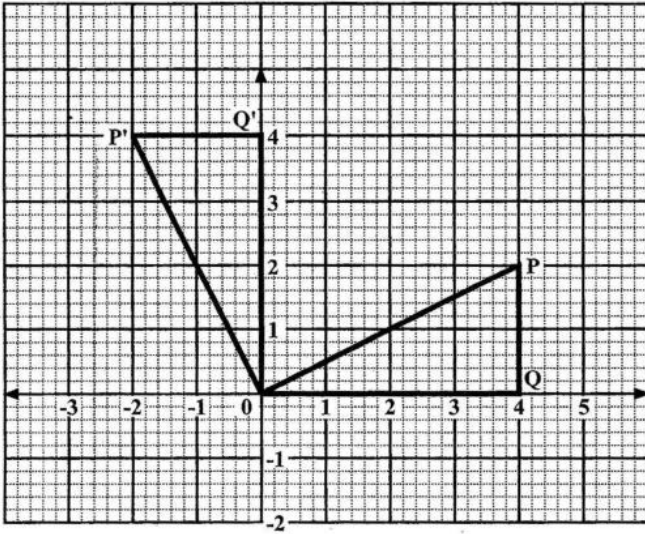

55. In the diagram,  $\Delta OPQ$  is mapped onto  $\Delta OP'Q'$ . What type of transformation has taken place?

- (A) Reflection
- (B) Enlargement
- (C) Translation
- (D) Rotation

Item 56 refers to the following pair of similar triangles.

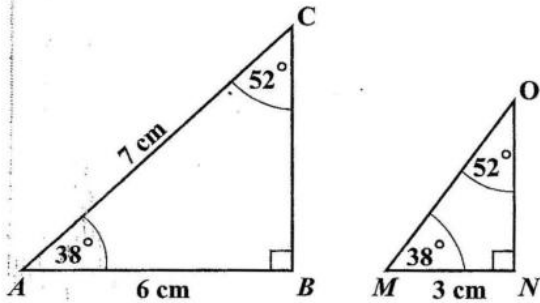

56. The length of  $MO$ , in centimetres, is

- (A) 3
- (B) 3.5
- (C) 6
- (D) 7

Item 57 refers to triangle ABC below.

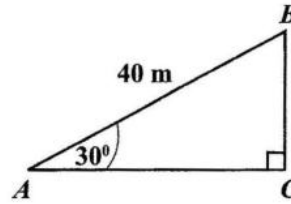

57. In the triangle, **not drawn to scale**, angle  $BAC = 30^\circ$  and  $AB = 40$  m. The length  $BC$ , in metres, is

- (A)  $40 \sin 30^\circ$
- (B)  $40 \tan 30^\circ$
- (C)  $40 \sin 60^\circ$
- (D)  $40 \tan 60^\circ$

Item 58 refers to the diagram below.

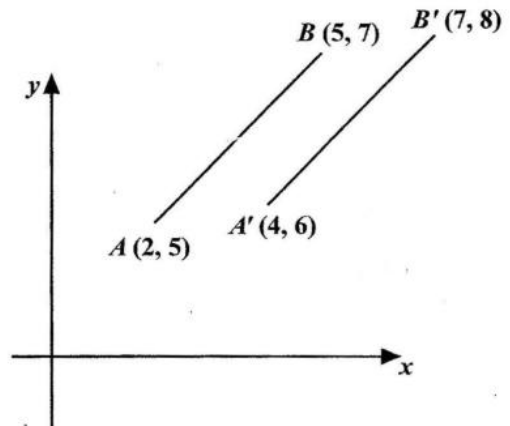

58. In the diagram, the translation by which  $AB$  is mapped onto  $A'B'$  is represented by

- (A)  $\begin{pmatrix} 1 \\ 1 \end{pmatrix}$
- (B)  $\begin{pmatrix} 2 \\ 1 \end{pmatrix}$
- (C)  $\begin{pmatrix} 3 \\ 2 \end{pmatrix}$
- (D)  $\begin{pmatrix} 5 \\ 3 \end{pmatrix}$

GO ON TO THE NEXT PAGE

Item 59 refers to the diagram below which shows a ladder 5 metres long leaning against a vertical wall. The foot of the ladder is on horizontal ground about 3 metres away from the wall.

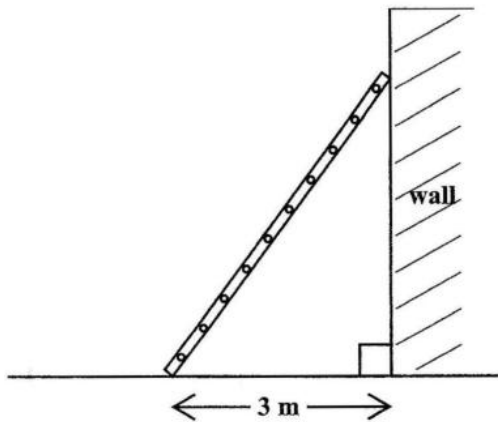

59. How far up the wall does the ladder reach?

- (A) 4 m
- (B) 6 m
- (C) 8 m
- (D) 15 m

Item 60 refers to the diagram of a building below.

A surveyor sets up his instruments 12 metres from the foot of a building, and records the angle of elevation of the top of the building.

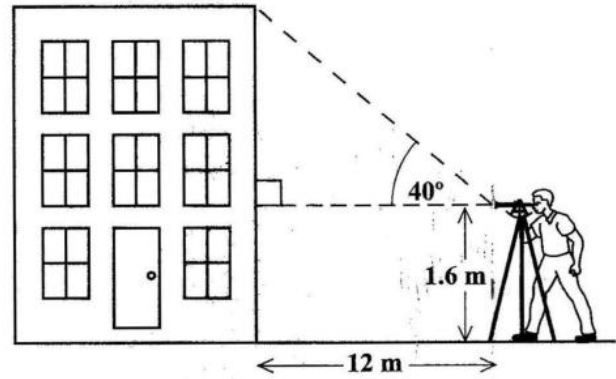

60. An estimate of the height of the building is obtained by calculating

- (A)  $12 \tan 40^\circ$
- (B)  $12 \sin 40^\circ$
- (C)  $1.6 + 12 \cos 40^\circ$
- (D)  $1.6 + 12 \tan 40^\circ$

END OF TEST

IF YOU FINISH BEFORE TIME IS CALLED, CHECK YOUR WORK ON THIS TEST.

1. In standard form 0.0325 is written as
- (A)  $3.25 \times 10^{-3}$   
(B)  $3.25 \times 10^{-2}$   
(C)  $3.25 \times 10^{-1}$   
(D)  $3.25 \times 10^2$
2. What percentage of 40 is 8?
- (A) 5 %  
(B) 20 %  
(C) 32 %  
(D) 150 %
3. 540 beads are shared in the ratio 4:5. The LARGER share of beads is
- (A) 60  
(B) 240  
(C) 300  
(D) 432
4.  $18.96 \times 2.03$  correct to two significant figures equals
- (A) 0.38  
(B) 38  
(C) 38.10  
(D) 380
5. 0.45 written as a common fraction, in its simplest form, is
- (A)  $\frac{9}{20}$   
(B)  $\frac{4}{5}$   
(C)  $\frac{9}{10}$   
(D)  $\frac{5}{4}$
6. The EXACT value of  $\frac{37.26 \div 1.8}{1000}$  is
- (A) 0.207  
(B) 0.0207  
(C) 20.7000  
(D) 20 700
7.  $3.3 \times 2.5 + 5.7 \times 2.5 =$
- (A) 8.25  
(B) 9.00  
(C) 13.25  
(D) 22.50
8. What is the value of the digit 2 in the number 48.621?
- (A)  $\frac{2}{100}$   
(B)  $\frac{2}{10}$   
(C) 2  
(D) 200
9. The LARGEST prime number that is less than 100 is
- (A) 91  
(B) 93  
(C) 97  
(D) 99
10. If  $3n$  is an odd number, which of the following is an even number?
- (A)  $3n - 1$   
(B)  $3n + 2$   
(C)  $3n - 2$   
(D)  $3n + 2n$

Item 11 refers to the following information.

$$P = \{\text{prime numbers}\}$$

$$Q = \{\text{odd numbers}\}$$

$$R = \{\text{even numbers}\}$$

11. Which of the following sets is empty?

(A)  $P \cap R$

(B)  $P \cup Q$

(C)  $P \cap Q$

(D)  $Q \cap R$

12. The set  $\{x : 6 \leq x < 10, \text{ where } x \text{ is an integer}\}$  is

(A)  $\{6, 7, 8, 9\}$

(B)  $\{6, 7, 8, 9, 10\}$

(C)  $\{7, 8, 9\}$

(D)  $\{7, 8, 9, 10\}$

13. If  $Q = \{a, b, c\}$  how many subsets can be obtained from the set  $Q$ ?

(A)  $2 + 3$

(B)  $2 \times 3$

(C)  $3^2$

(D)  $2^3$

Item 14 refers to the following information.

$$M = \{p, q, r\}$$

$$N = \{p, q\}$$

14. Which of the following statements is TRUE?

(A)  $M \subset N$

(B)  $M \cup N = N$

(C)  $M \cap N = \{ \}$

(D)  $M \cap N = N$

15. If TT\$6.00 is equivalent to US\$1.00, then TT\$15.00 in US dollars is

(A) \$0.25

(B) \$0.40

(C) \$2.50

(D) \$4.00

16. The cost price of a refrigerator is \$1850.00. A buyer who is given a discount of 5% for a cash purchase will pay

(A) \$1942.50

(B) \$1845.00

(C) \$1757.50

(D) \$1350.00

17. Tom bought a pen for \$30 and sold it to gain 20% on his cost price. How much money did he gain?

(A) \$ 6

(B) \$20

(C) \$36

(D) \$40

18. A dinner at a restaurant was advertised at \$60 plus 18% tax. The total bill for this dinner was

(A) \$60.00

(B) \$70.80

(C) \$78.00

(D) \$81.60

19. A television set costs \$350 cash. When bought on hire-purchase, a deposit of \$35 is required, followed by 12 monthly payments of \$30. How much is saved by paying cash?

(A) \$10

(B) \$25

(C) \$40

(D) \$45

20. The simple interest on a sum of money invested at 5% per annum for 3 years was \$90.
- The sum of money invested was
- (A) \$ 54  
 (B) \$ 150  
 (C) \$ 600  
 (D) \$1350
21. A woman buys a pair of shoes at a sale. She pays \$45, saving \$15 on the normal price. The percentage discount on the pair of shoes is
- (A) 25  
 (B) 30  
 (C)  $33\frac{1}{3}$   
 (D) 80
22. If the simple interest on \$900 for 3 years was \$108, what was the rate of interest?
- (A) 3%  
 (B) 4%  
 (C) 12%  
 (D) 25%
23.  $3x^2 \times 2x^3 =$
- (A)  $6x^5$   
 (B)  $5x^5$   
 (C)  $6x^6$   
 (D)  $72x^5$
24.  $\frac{1}{5x} + \frac{2}{3x} =$
- (A)  $\frac{3}{8x^2}$   
 (B)  $\frac{3}{8x}$   
 (C)  $\frac{13}{15x^2}$   
 (D)  $\frac{13}{15x}$
25. Using the distributive law,  $(p \times q) - (p \times r)$  is simplified to
- (A)  $-qr$   
 (B)  $-2pqr$   
 (C)  $p^2 - qr$   
 (D)  $p(q - r)$
26. If  $x = -2, y = 3, t = 2$ , then  $\left(\frac{x}{y}\right)^t =$
- (A)  $-\frac{4}{9}$   
 (B)  $\frac{4}{9}$   
 (C)  $\frac{4}{3}$   
 (D)  $\frac{9}{4}$
27. If  $p * q = 2p + q$ , then  $2 * 3$  is
- (A) 5  
 (B) 7  
 (C) 8  
 (D) 9

28. If  $5(2x - 1) = 35$ , then  $x =$

- (A)  $-4$   
 (B)  $\frac{1}{4}$   
 (C)  $3$   
 (D)  $4$

29. What is the value of  $\frac{x^2 + 3y}{xy}$ , if  $x = 4$  and  $y = 2$ ?

- (A)  $1\frac{3}{4}$   
 (B)  $2\frac{1}{2}$   
 (C)  $2\frac{3}{8}$   
 (D)  $2\frac{3}{4}$

30. When 6 is added to a number and the sum is divided by three, the result is four. This statement written in mathematical symbols is

- (A)  $\frac{6+x}{3} = 4$   
 (B)  $\frac{6}{3} + x = 4$   
 (C)  $\frac{6+x}{3} = \frac{4}{3}$   
 (D)  $6 + \frac{x}{3} = 4$

31. When 5 is added to a certain number and the result is multiplied by 3 the final answer is 27. What is the **original** number?

- (A)  $4$   
 (B)  $12$   
 (C)  $14$   
 (D)  $19$

32. 3 800 millimetres expressed in metres is

- (A)  $0.38$   
 (B)  $3.8$   
 (C)  $38$   
 (D)  $380$

Item 33 refers to the following diagram.

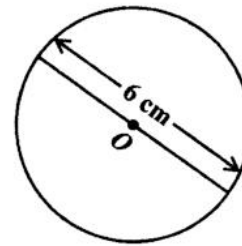

33. The circle shown in the diagram, **not drawn to scale**, has a centre at  $O$ . The area of the circle, in  $\text{cm}^2$ , is

- (A)  $6\pi$   
 (B)  $9\pi$   
 (C)  $12\pi$   
 (D)  $36\pi$

34. 10 800 seconds expressed in hours is

- (A)  $3$   
 (B)  $18$   
 (C)  $30$   
 (D)  $180$

35. The volume, in  $\text{cm}^3$ , of a cube of edge 3 cm is

- (A)  $9$   
 (B)  $18$   
 (C)  $27$   
 (D)  $54$

Item 36 refers to the following diagram.

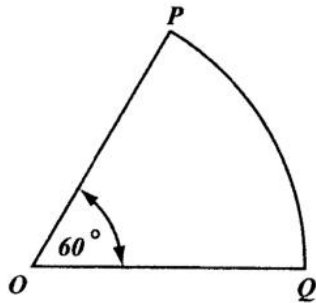

36. The figure above, not drawn to scale, shows a sector of a circle centre  $O$ . The length of the minor arc  $PQ$  is 8 cm. What is the length of the circumference of the circle?
- (A) 16 cm  
 (B) 24 cm  
 (C) 48 cm  
 (D) 64 cm

37. A man started a journey at 09:30 h and arrived at his destination, in the same time zone, at 13:30 h on the same day. If his average speed was 30 km/h, then the distance, in km, for the journey was
- (A) 120  
 (B) 133  
 (C) 400  
 (D) 430

Item 38 refers to the following diagram.

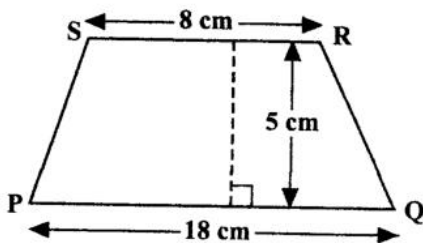

38. The area of the trapezium PQRS above is
- (A) 45 cm<sup>2</sup>  
 (B) 65 cm<sup>2</sup>  
 (C) 90 cm<sup>2</sup>  
 (D) 130 cm<sup>2</sup>

Item 39 refers to the following diagram.

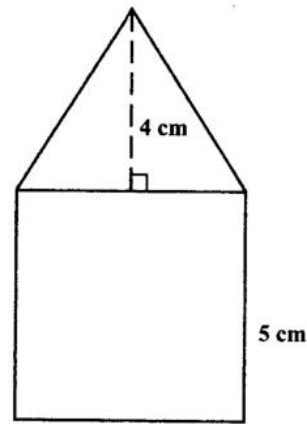

39. The diagram above, **not drawn to scale**, consists of a triangle resting on a square of side 5 cm. The height of the triangle is 4 cm.

What is the TOTAL area of the figure?

- (A) 35 cm<sup>2</sup>  
 (B) 45 cm<sup>2</sup>  
 (C) 50 cm<sup>2</sup>  
 (D) 100 cm<sup>2</sup>
40. The score which occurs most frequently in a distribution is defined as the
- (A) median  
 (B) mean  
 (C) range  
 (D) mode

Item 41 refers to the following bar chart.

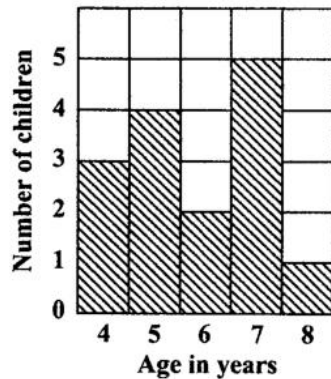

41. The bar chart shows the ages of children who took part in a survey.

How many children took part in the survey?

- (A) 5
- (B) 15
- (C) 75
- (D) 87

Item 42 refers to the eight scores below.

10	15	4	7
8	8	1	4

42. The median of the scores presented above is

- (A) 4
- (B) 7.25
- (C) 7.50
- (D) 8

43. In a class of 20 students, 12 are girls. What is the probability that a student chosen at random is a boy?

- (A)  $\frac{1}{20}$
- (B)  $\frac{8}{20}$
- (C)  $\frac{12}{20}$
- (D)  $\frac{8}{12}$

Item 44 refers to the following diagram.

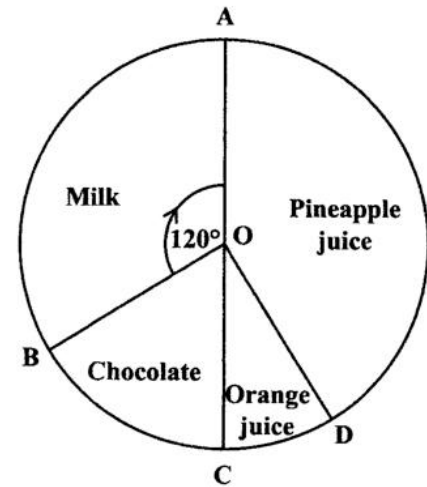

44. The piechart above shows the preference in drinks of a group of students. Each student may select only one drink.

If 12 students prefer chocolate, then the TOTAL number of students is

- (A) 48
- (B) 72
- (C) 180
- (D) 360

45. If the mean of the numbers  $2x$ ,  $3x$ ,  $4x$  and  $3x$  is 12, then the sum of the numbers is

- (A) 4
- (B) 12
- (C) 48
- (D) 80

46. The equation of the line which passes through the point  $(0,5)$  and has a gradient of 4 is

- (A)  $y = 4x$
- (B)  $y = 5x$
- (C)  $y = 4x + 5$
- (D)  $y = 5x + 4$

Item 47 refers to the following graph.

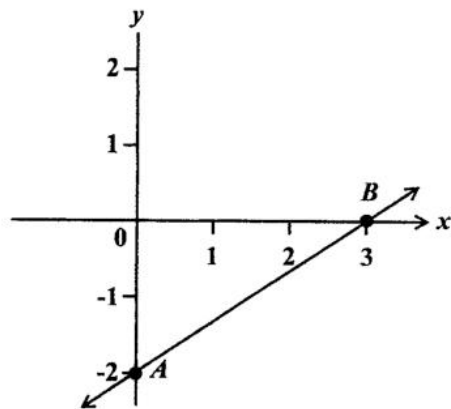

47. The straight line AB cuts the  $y$  axis at
- (A) (0, 3)
  - (B) (0, 2)
  - (C) (3, -2)
  - (D) (0, -2)

Item 48 refers to the following graph.

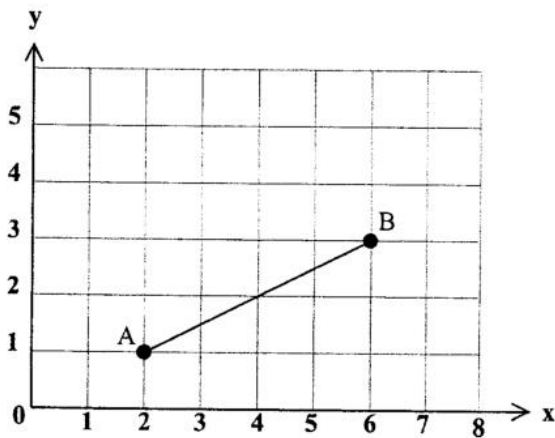

48. The gradient of AB in the graph above is
- (A) -2
  - (B) 2
  - (C)  $-\frac{1}{2}$
  - (D)  $\frac{1}{2}$

49. If  $f(x) = x^2 - x - 1$ , then  $f(-5) =$

- (A) 19
- (B) 24
- (C) 29
- (D) 31

50. What is the gradient of the straight line  $2y = -3x - 8$ ?

- (A) -3
- (B)  $-\frac{3}{2}$
- (C) 2
- (D) 3

51. The range of  $f: x \rightarrow x^5$  for the domain  $\{-2, -1, 0, 1, 2\}$  is

- (A)  $\{32, 1, 0, 1, 32\}$
- (B)  $\{10, 5, 0, 5, 10\}$
- (C)  $\{-10, -3, 0, 3, 10\}$
- (D)  $\{-32, -1, 0, 1, 32\}$

Item 52 refers to the following diagram.

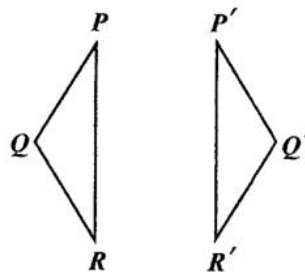

52. What transformation maps  $PQR$  onto  $P'Q'R'$ ?

- (A) Enlargement
- (B) Rotation
- (C) Translation
- (D) Reflection

53. The image of a point  $P(1, 2)$  under a translation is  $P'(-5, -4)$ . What is the translation vector?

- (A)  $\begin{pmatrix} -6 \\ -6 \end{pmatrix}$   
 (B)  $\begin{pmatrix} -4 \\ -2 \end{pmatrix}$   
 (C)  $\begin{pmatrix} 4 \\ 2 \end{pmatrix}$   
 (D)  $\begin{pmatrix} 6 \\ 6 \end{pmatrix}$

Item 54 refers to the following diagram.

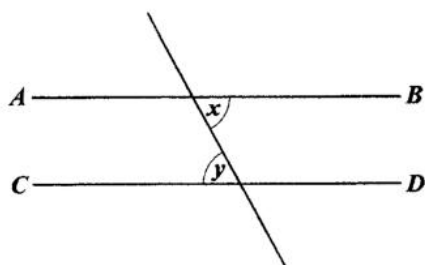

54. In the diagram  $AB$  and  $CD$  are parallel. Which of the following BEST describes the relation between  $x$  and  $y$ ?

- (A)  $x = y$   
 (B)  $x > y$   
 (C)  $x + y > 2x$   
 (D)  $x + y < 2x$

Item 55 refers to triangle  $ABC$  below.

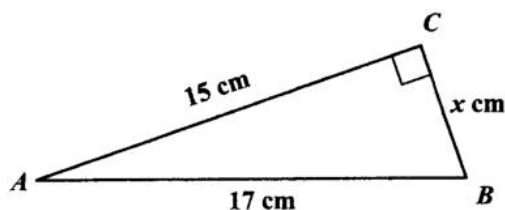

55. In the triangle  $ABC$ , not drawn to scale,  $AB$  is 17 cm,  $AC$  is 15 cm,  $BC$  is  $x$  cm and angle  $BCA$  is  $90^\circ$ . The value of  $x$  is

- (A) 7  
 (B) 8  
 (C) 9  
 (D) 12

Item 56 refers to the following diagram.

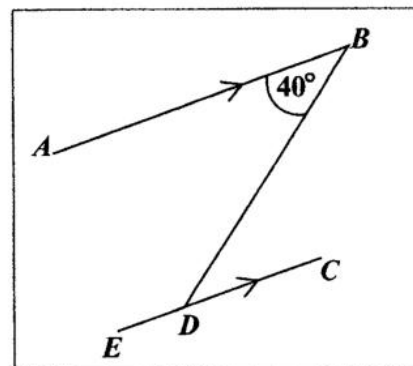

56. In the diagram,  $AB$  is parallel to  $EC$ . The measure of  $\angle BDE$  is

- (A)  $40^\circ$   
 (B)  $50^\circ$   
 (C)  $140^\circ$   
 (D)  $180^\circ$

Item 57 refers to the diagram below.

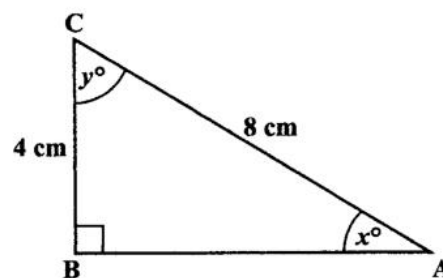

57. In the right-angled triangle above, which trigonometric ratio is equal to  $\frac{4}{8}$ ?

- (A)  $\sin x$   
 (B)  $\tan y$   
 (C)  $\cos x$   
 (D)  $\tan x$

Item 58 refers to the following diagram.

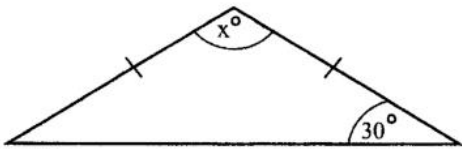

58. In the isosceles triangle shown above, the value of  $x$  is

- (A) 30
- (B) 60
- (C) 120
- (D) 150

Item 59 refers to the following diagram.

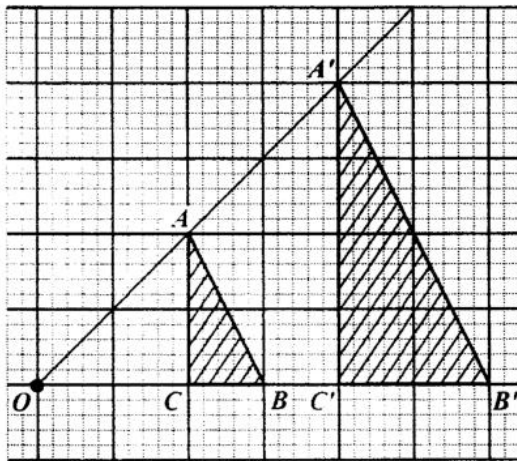

59.  $OAA'$ ,  $OBB'$  and  $OCC'$  are straight lines.  $\triangle ABC$  is mapped onto  $\triangle A'B'C'$  by an enlargement with centre  $O$ . What is the scale factor of the enlargement?

- (A)  $\frac{1}{2}$
- (B)  $-\frac{1}{2}$
- (C) 2
- (D) -2

Item 60 refers to the following diagram.

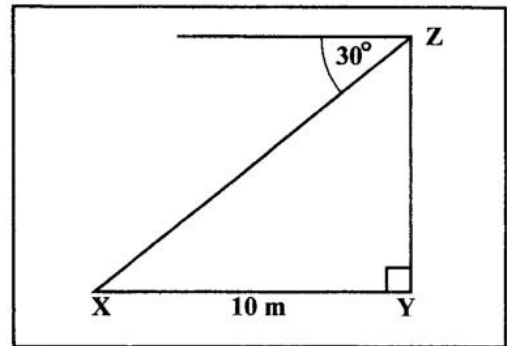

60. The diagram above, **not drawn to scale**, shows the angle of depression of a point  $X$  from  $Z$  is  $30^\circ$ . If  $X$  is 10 metres from  $Y$ , the height of  $YZ$ , in metres, is

- (A)  $10 \tan 30^\circ$
- (B)  $10 \sin 30^\circ$
- (C)  $10 \cos 30^\circ$
- (D)  $10 \cos 60^\circ$

END OF TEST

IF YOU FINISH BEFORE TIME IS CALLED, CHECK YOUR WORK ON THIS TEST.

**CANDIDATE PLEASE NOTE!**

PRINT your name on the line below and return this booklet with the answer sheet. Failure to do so may result in disqualification.

TEST CODE **01234010**

FORM TP 2017084

MAY/JUNE 2017

**CARIBBEAN EXAMINATIONS COUNCIL**  
**CARIBBEAN SECONDARY EDUCATION CERTIFICATE®**  
**EXAMINATION**

**MATHEMATICS****Paper 01 – General Proficiency***1 hour 30 minutes*

10 MAY 2017 (p.m.)

**READ THE FOLLOWING INSTRUCTIONS CAREFULLY.**

1. This test consists of 60 items. You will have 1 hour and 30 minutes to answer them.
2. In addition to this booklet, you should have an answer sheet.
3. A list of formulae is provided on page 2 of this booklet.
4. Each item in this test has four suggested answers lettered (A), (B), (C), (D). Read each item you are about to answer and decide which choice is best.
5. On your answer sheet, find the number which corresponds to your item and shade the space having the same letter as the answer you have chosen. Look at the sample item below.

Sample Item

$2a + 6a =$

- (A)  $8a$   
 (B)  $8a^2$   
 (C)  $12a$   
 (D)  $12a^2$

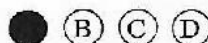
Sample Answer

The best answer to this item is " $8a$ ", so (A) has been shaded.

6. If you want to change your answer, erase it completely before you fill in your new choice.
7. When you are told to begin, turn the page and work as quickly and as carefully as you can. If you cannot answer an item, go on to the next one. You may return to that item later.
8. You may do any rough work in this booklet.
9. Calculators and mathematical tables are NOT allowed for this paper.

---

**DO NOT TURN THIS PAGE UNTIL YOU ARE TOLD TO DO SO.**

---

LIST OF FORMULAE

Volume of a prism  $V = Ah$  where  $A$  is the area of the cross-section and  $h$  is the perpendicular length.

Volume of cylinder  $V = \pi r^2 h$  where  $r$  is the radius of the base and  $h$  is the perpendicular height.

Volume of a right pyramid  $V = \frac{1}{3} Ah$  where  $A$  is the area of the base and  $h$  is the perpendicular height.

Circumference of a circle  $C = 2\pi r$  where  $r$  is the radius of the circle.

Arc length  $S = \frac{\theta}{360} \times 2\pi r$  where  $\theta$  is the angle subtended by the arc, measured in degrees

Area of a circle  $A = \pi r^2$  where  $r$  is the radius of the circle.

Area of a sector of a circle  $A = \frac{\theta}{360} \times \pi r^2$  where  $\theta$  is the angle in the sector measured in degrees.

Area of trapezium  $A = \frac{1}{2} (a + b) h$  where  $a$  and  $b$  are the lengths of the parallel sides and  $h$  is the perpendicular distance between the parallel sides.

Roots of quadratic equations If  $ax^2 + bx + c = 0$ ,

$$\text{then } x = \frac{-b \pm \sqrt{b^2 - 4ac}}{2a}$$

Trigonometric ratios

$$\sin \theta = \frac{\text{opposite side}}{\text{hypotenuse}}$$

$$\cos \theta = \frac{\text{adjacent side}}{\text{hypotenuse}}$$

$$\tan \theta = \frac{\text{opposite side}}{\text{adjacent side}}$$

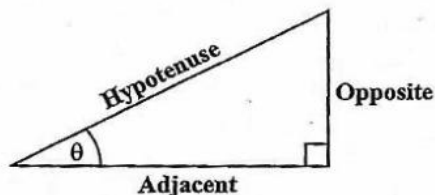

Area of triangle Area of  $\triangle ABC = \frac{1}{2}bh$  where  $b$  is the length of the base and  $h$  is the perpendicular height

$$\text{Area of } \triangle ABC = \frac{1}{2}ab \sin C$$

$$\text{Area of } \triangle ABC = \sqrt{s(s-a)(s-b)(s-c)}$$

$$\text{where } s = \frac{a+b+c}{2}$$

$$\frac{a}{\sin A} = \frac{b}{\sin B} = \frac{c}{\sin C}$$

Sine rule

Cosine rule

$$a^2 = b^2 + c^2 - 2bc \cos A$$

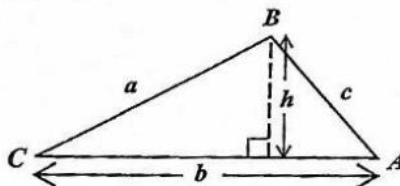

GO ON TO THE NEXT PAGE

1.  $(-3)^2 + (-2)^2$  is equal to
- (A) -13  
(B) -10  
(C) 13  
(D) 25
2. What number when added to  $1\frac{1}{3}$  gives 2?
- (A)  $\frac{1}{3}$   
(B)  $\frac{2}{3}$   
(C) 1  
(D) 3
3. Ann and Betty shared a sum of money in the ratio 2:3. If Ann received \$60 less than Betty, what was the total amount of money shared?
- (A) \$ 72  
(B) \$ 80  
(C) \$180  
(D) \$300
4. If  $235 \times 48.7 = 11\,444.5$ , then  $23.5 \times 0.487 =$
- (A) 11.4445  
(B) 114.445  
(C) 1 144.45  
(D) 11 444.4
5. A test was marked out of 80. A boy scored 60% of the marks on the test. How many marks did he score?
- (A) 20  
(B) 48  
(C) 60  
(D) 75
6. If 30% of a number is 45, what is  $\frac{4}{5}$  of the number?
- (A) 36  
(B) 120  
(C) 150  
(D) 180
7. What is the value of the digit 2 in the number 48.621?
- (A)  $\frac{2}{100}$   
(B)  $\frac{2}{10}$   
(C) 2  
(D) 200
8. The highest common factor (HCF) of 12, 15 and 60 is
- (A) 1  
(B) 3  
(C) 12  
(D) 60
9. The next term in the sequence 1, 6, 13, 22, 33 is
- (A) 44  
(B) 45  
(C) 46  
(D) 52
10. By the distributive law,  $49 \times 17 + 49 \times 3 =$
- (A)  $52 + 66$   
(B)  $52 \times 66$   
(C)  $49 + 20$   
(D)  $49 \times 20$

11. If  $P = \{2, 3, 5, 7\}$ ,  
 $Q = \{2, 3, 6\}$  and  
 $S = \{2, 4, 5\}$

Then  $P \cap Q \cap S =$

- (A)  $\{2\}$   
 (B)  $\{2, 3\}$   
 (C)  $\{2, 3, 5\}$   
 (D)  $\{2, 3, 4, 5, 6, 7\}$

Item 12 refers to the following Venn diagram.

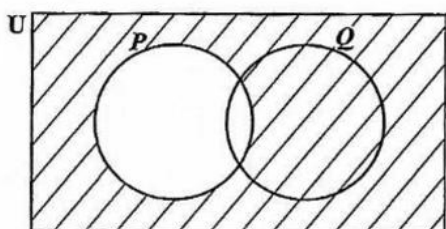

12. In the Venn diagram, the shaded area represents

- (A)  $P'$   
 (B)  $(P \cup Q)'$   
 (C)  $Q \cup P'$   
 (D)  $Q \cap P'$

13. In a class of 32 students, 17 study Music and 20 study Art. What is the LEAST number of students who study BOTH Music and Art?

- (A) 3  
 (B) 5  
 (C) 12  
 (D) 15

Item 14 refers to the following Venn diagram.

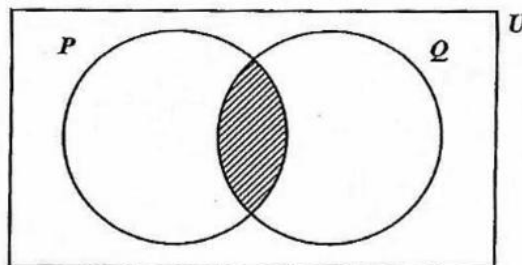

14. If  $P = \{\text{Factors of 6}\}$  and  $Q = \{\text{Factors of 4}\}$ , then the shaded region represents

- (A)  $\{ \}$   
 (B)  $\{1, 2\}$   
 (C)  $\{4, 6, 8, \dots\}$   
 (D)  $\{12, 24, 36, \dots\}$

15. A dress which costs \$180 is being sold at a discount of 10%. The amount of the discount is

- (A) \$ 1.80  
 (B) \$ 10.00  
 (C) \$ 18.00  
 (D) \$170.00

16. The value of a plot of land is \$18 000. Land tax is charged at the rate of \$0.70 per \$100 value. What is the TOTAL amount of tax paid for the land?

- (A) \$110.00  
 (B) \$126.00  
 (C) \$180.70  
 (D) \$257.15

17. At the end of any year a car is worth 5% less than what it was worth at the beginning of the year. If a car is worth \$9 500 in December 2016, then its value in January 2016 was

- (A) \$ 9 995  
 (B) \$10 000  
 (C) \$10 025  
 (D) \$12 000

GO ON TO THE NEXT PAGE

18. A man bought a mobile phone for \$800 and sold it for \$1 000. What was his profit as a percentage of the cost price?
- (A) 5%  
(B) 15%  
(C) 20%  
(D) 25%
19. A man's annual salary is \$45 000. His tax-free allowances total \$13 000. He pays tax of 35% on his taxable income. The tax payable is
- (A) \$ 4 550  
(B) \$11 200  
(C) \$15 750  
(D) \$20 300
20. The simple interest on a loan of \$6 000 for 3 years was \$900. What was the rate of interest per annum?
- (A) 2%  
(B) 3%  
(C) 5%  
(D) 18%
21. A television set costs \$350 cash. When bought on hire-purchase, a deposit of \$35 is required, followed by 12 monthly payments of \$30 each. How much is saved by paying cash?
- (A) \$10  
(B) \$25  
(C) \$40  
(D) \$45
22. How much does a customer pay for an article marked at \$50 if a sales tax of 6% is charged?
- (A) \$44  
(B) \$47  
(C) \$53  
(D) \$56
23. Seven times the product of two numbers,  $a$  and  $b$ , may be written as
- (A)  $7ab$   
(B)  $49ab$   
(C)  $7a + b$   
(D)  $7(a + b)$
24. If  $x$  is an integer that satisfies the inequality  $4 < 2x \leq 6$ , then
- (A)  $2 < x \leq 3$   
(B)  $-2 < x \leq 3$   
(C)  $-3 < x \leq 2$   
(D)  $-3 \leq x < -2$
25. The coefficient of  $x$  in the expansion of  $(x + 3)(x - 1)$  is
- (A) -3  
(B) -2  
(C) 2  
(D) 4
26.  $3x^2 \times 2x^3 =$
- (A)  $6x$   
(B)  $6x^5$   
(C)  $6x^6$   
(D)  $72x^5$

27.  $P = \frac{m^3}{2-m}$ . When  $m = -2$ , the value of  $P$  is
- (A)  $-2$   
(B)  $\frac{-6}{4}$   
(C)  $\frac{6}{4}$   
(D)  $2$
28. If  $a * b = \frac{a}{b} - 1$ , then  $7 * 28 =$
- (A)  $-\frac{3}{4}$   
(B)  $\frac{1}{4}$   
(C)  $3$   
(D)  $4$
29. If  $5(2x - 1) = 35$ , then  $x =$
- (A)  $-4$   
(B)  $\frac{1}{4}$   
(C)  $3$   
(D)  $4$
30. John has  $x$  marbles and Max has twice as many marbles as John. Max gives John 5 of his marbles. How many marbles does John now have?
- (A)  $x + 5$   
(B)  $x - 5$   
(C)  $2x - 5$   
(D)  $2x + 5$
31. When 8 is subtracted from a certain number and the result is multiplied by 3 the answer is 21. What is the original number?
- (A) 1  
(B) 3  
(C) 10  
(D) 15
32. How many kilograms are there in one tonne?
- (A) 10  
(B) 100  
(C) 1 000  
(D) 10 000
33. The volume, in  $\text{cm}^3$ , of a cube of edge 3 cm is
- (A) 9  
(B) 18  
(C) 27  
(D) 54
34. A car travels 80 kilometres in  $2\frac{1}{2}$  hours. What is its speed, in kilometres per hour?
- (A) 6  
(B) 32  
(C) 82.5  
(D) 200

GO ON TO THE NEXT PAGE

Item 35 refers to the following figure which shows a triangle resting on a square.

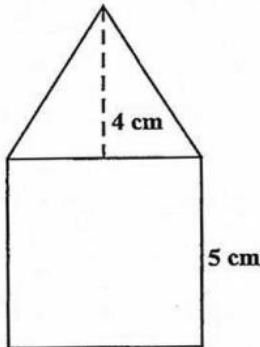

35. The length of one side of the square is 5 cm and the height of the triangle is 4 cm. What is the TOTAL area of the figure, in  $\text{cm}^2$ ?
- (A) 35  
(B) 45  
(C) 50  
(D) 100
36. The area of a rectangle is  $53.6 \text{ cm}^2$ . If the length is multiplied by four and the width is halved, the area would then be
- (A)  $26.8 \text{ cm}^2$   
(B)  $53.6 \text{ cm}^2$   
(C)  $107.2 \text{ cm}^2$   
(D)  $214.4 \text{ cm}^2$
37. A man leaves home at 22:15 hours and reaches his destination at 04:00 hours on the following day in the same time zone. How many hours did the journey take?
- (A) 5  
(B)  $5\frac{3}{4}$   
(C) 6  
(D)  $6\frac{1}{4}$

38. The distance around a lake is 8 km. On a map, this distance around the lake is represented by a length of 2 cm. The scale on the map is
- (A) 1 : 40  
(B) 1 : 2 000  
(C) 1 : 200 000  
(D) 1 : 400 000
39. The perimeter of a square is 56 cm. What is its area, in  $\text{cm}^2$ ?
- (A) 28  
(B) 78  
(C) 169  
(D) 196

Item 40 refers to the following diagram, **not drawn to scale**, of a cylinder of radius 3 cm and height 8 cm.

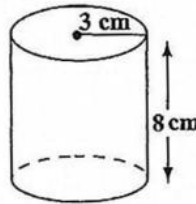

40. The volume of the cylinder is
- (A)  $12 \pi \text{ cm}^3$   
(B)  $48 \pi \text{ cm}^3$   
(C)  $72 \pi \text{ cm}^3$   
(D)  $192 \pi \text{ cm}^3$

GO ON TO THE NEXT PAGE

Items 41–42 refer to the following histogram which shows the number of children aged 4, 5, 6, 7 and 8 who took part in a survey.

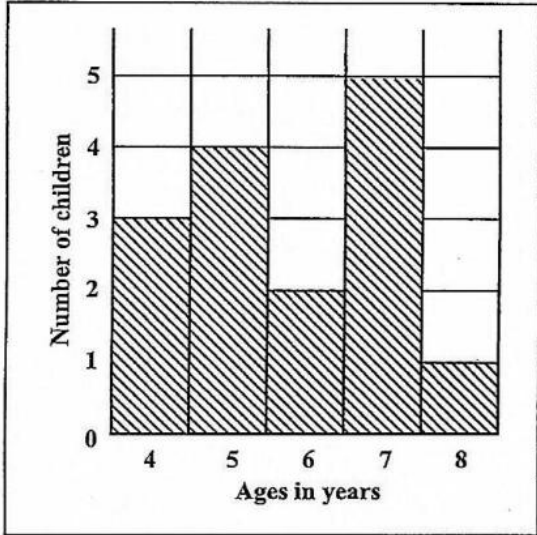

41. What was the modal age?
- (A) 5  
(B) 6  
(C) 7  
(D) 8
42. How many children took part in the survey?
- (A) 5  
(B) 15  
(C) 75  
(D) 87

43. The following table shows the frequency of scores obtained by students in a test.

Scores	2	3	5	6	8	10
No. of Students	8	4	6	3	9	2

The range of the scores is

- (A) 2  
(B) 7  
(C) 8  
(D) 10

44. If the mean of the four numbers 4, 8,  $2x$  and 12 is 10, then  $x$  is
- (A) 8  
(B) 10  
(C) 12  
(D) 16

45. Of 120 students writing an exam, 100 are expected to pass. The estimated probability that a randomly selected student will FAIL the exam is
- (A)  $\frac{1}{6}$   
(B)  $\frac{1}{5}$   
(C)  $\frac{1}{2}$   
(D)  $\frac{5}{6}$

46. Which of the following diagrams BEST illustrates a function?

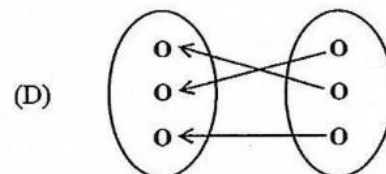
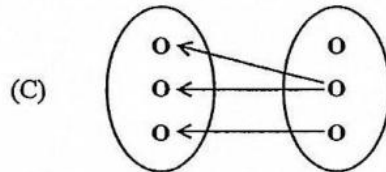
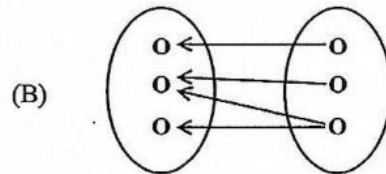
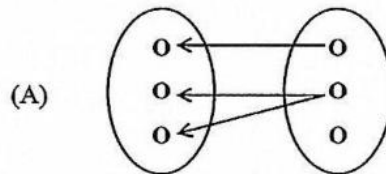

GO ON TO THE NEXT PAGE

Item 47 refers to the following graph of a straight line.

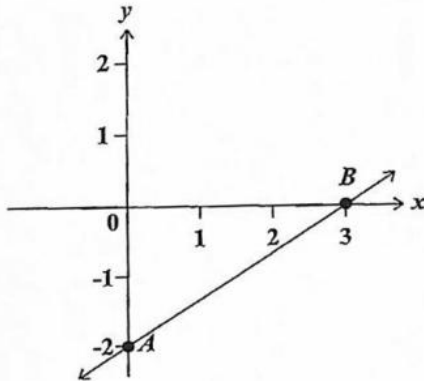

47. The straight line  $AB$  cuts the  $y$  axis at
- (A)  $(0, 3)$
  - (B)  $(0, 2)$
  - (C)  $(3, -2)$
  - (D)  $(0, -2)$

48. If  $h(x) = \frac{3x-2}{5}$ , then  $h(-6) =$

- (A)  $-4$
- (B)  $\frac{-16}{5}$
- (C)  $\frac{16}{5}$
- (D)  $4$

Item 49 refers to the following number line which shows the solution of an inequality.

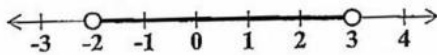

49. The inequality above is defined by
- (A)  $-2 \leq x < 3$
  - (B)  $-2 < x \leq 3$
  - (C)  $-2 \leq x \leq 3$
  - (D)  $-2 < x < 3$

Item 50 refers to the following graph of a function.

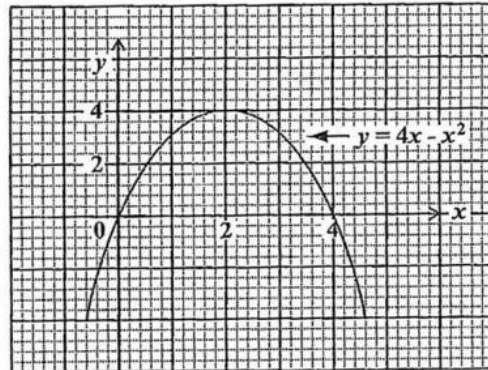

50. The values of  $x$  for which  $y = 4x - x^2$  intersects  $y = 0$  are
- (A)  $x = 0$  and  $x = 4$
  - (B)  $x = 0$  and  $x = 2$
  - (C)  $x = 0$  and  $x = -4$
  - (D)  $x = 2$  and  $x = 4$

Item 51 refers to the following arrow diagram which shows a function.

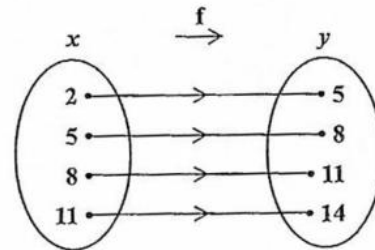

51. Which of the following BEST describes the function?
- (A)  $f(x) = x$
  - (B)  $x = f(x) + 3$
  - (C)  $f(x) = y + 3$
  - (D)  $f(x) = x + 3$

52. If each exterior angle of a regular polygon is  $60^\circ$ , then the polygon is a
- (A) quadrilateral
  - (B) pentagon
  - (C) hexagon
  - (D) triangle

GO ON TO THE NEXT PAGE

Item 53 refers to the following diagram of a pair of intersecting lines.

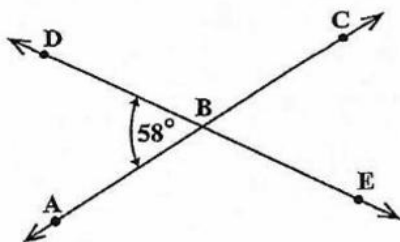

53. The measure of angle  $ABE$  is

- (A)  $58^\circ$
- (B)  $122^\circ$
- (C)  $142^\circ$
- (D)  $302^\circ$

Item 54 refers to the following diagram of an isosceles triangle.



54. In the triangle, the value of  $x$  is

- (A)  $30^\circ$
- (B)  $60^\circ$
- (C)  $120^\circ$
- (D)  $150^\circ$

Item 55 refers to the following diagram of the straight line  $y = x$ .

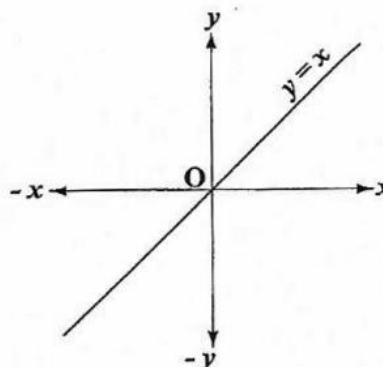

55. What is the image of the line  $y = x$  when it is rotated anticlockwise about  $O$  through an angle of  $90^\circ$ ?

- (A)  $y = 0$
- (B)  $x = 0$
- (C)  $y = x$
- (D)  $y = -x$

Item 56 refers to the following pair of similar triangles.

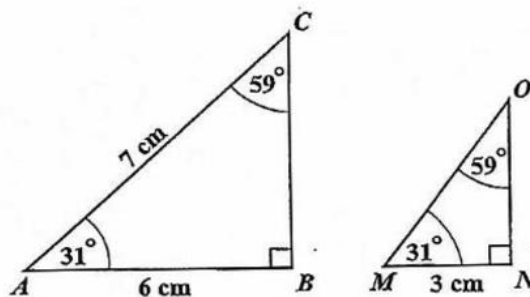

56. The length of  $MO$ , in centimetres, is

- (A) 2.5
- (B) 3.0
- (C) 3.5
- (D) 7.0

GO ON TO THE NEXT PAGE

Item 57 refers to the following right-angled triangle,  $ABC$ .

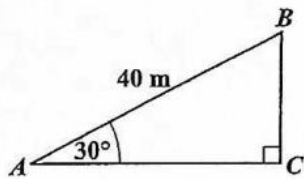

57. In the triangle, **not drawn to scale**, angle  $BAC = 30^\circ$  and  $AB = 40\text{ m}$ . The length  $BC$ , in metres, is

- (A)  $40 \sin 30^\circ$   
 (B)  $40 \tan 30^\circ$   
 (C)  $40 \sin 60^\circ$   
 (D)  $40 \tan 60^\circ$

Item 58 refers to the following right-angled triangle,  $ABC$ .

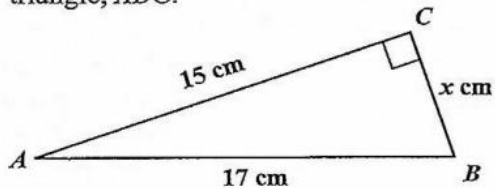

58. In the triangle  $ABC$ , **not drawn to scale**,  $AB$  is  $17\text{ cm}$ ,  $AC$  is  $15\text{ cm}$  and  $BC$  is  $x\text{ cm}$ . The value of  $x$ , in centimetres, is

- (A) 7  
 (B) 8  
 (C) 9  
 (D) 12

59. In a triangle,  $PQR$ , angle  $P = x^\circ$  and angle  $Q = 2x^\circ$ . What is the size of angle  $R$ ?

- (A)  $60^\circ$   
 (B)  $45^\circ$   
 (C)  $\left(\frac{180}{3x}\right)^\circ$   
 (D)  $(180^\circ - 3x^\circ)$

Item 60 refers to the following diagram of a building.

A surveyor sets up his instruments  $12$  metres from the foot of a building, and records the angle of elevation of the top of the building.

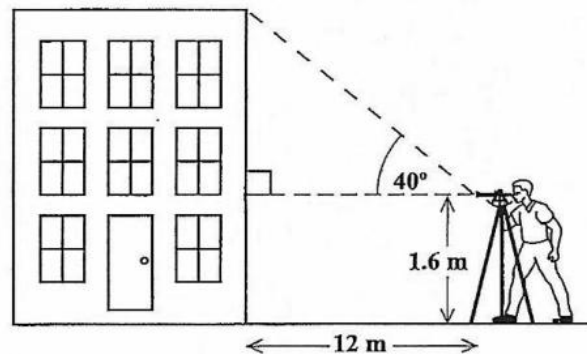

60. An estimate of the height of the building is obtained by calculating

- (A)  $12 \tan 40^\circ$   
 (B)  $12 \sin 40^\circ$   
 (C)  $1.6 + 12 \cos 40^\circ$   
 (D)  $1.6 + 12 \tan 40^\circ$

END OF TEST

IF YOU FINISH BEFORE TIME IS CALLED, CHECK YOUR WORK ON THIS TEST.

- 3 -

1. What percentage of 40 is 8?
- (A) 5  
(B) 20  
(C) 32  
(D) 150
2. The exact value of  $6 \div (0.0003)$  is
- (A) 200  
(B) 2 000  
(C) 20 000  
(D) 200 000
3. If  $6 \times 10^{-n} = 0.06$ ,  $n > 0$ , then  $n$  is
- (A) 1  
(B) 2  
(C) 3  
(D) 4
4. Paula bought  $1 \frac{7}{8}$  m of fabric to make a shirt, while Rita bought  $1 \frac{3}{4}$  m to make her shirt. How much MORE fabric did Paula buy than Rita?
- (A)  $\frac{1}{8}$  m  
(B)  $\frac{1}{2}$  m  
(C)  $1 \frac{1}{8}$  m  
(D)  $3 \frac{5}{8}$  m
5. The value of  $29.94 \times 0.5$  is approximately
- (A) 0.15  
(B) 1.5  
(C) 15  
(D) 150
6. There are 40 students in a class. Girls make up 60% of the class. 25% of the girls wear glasses. How many girls in the class wear glasses?
- (A) 6  
(B) 8  
(C) 10  
(D) 15
7.  $(3 \times 7) + (3 \times 5)$  is the same as
- (A)  $3 \times 5 + 7$   
(B)  $3 \times 7 + 5$   
(C)  $3 \times (7 + 5)$   
(D)  $(3 + 7) \times 5$
8. What is the HIGHEST common factor of the set of numbers {30, 45, 90}?
- (A) 3  
(B) 5  
(C) 15  
(D) 90
9. What is the LEAST number of plums that can be shared equally among either 6, 9 or 12 children?
- (A) 27  
(B) 36  
(C) 54  
(D) 72
10. If  $3n$  is an odd number, which of the following is an even number?
- (A)  $3n - 1$   
(B)  $3n + 2$   
(C)  $3n - 2$   
(D)  $3n + 2n$

11. If  $A = \{3, 6, 9\}$ , then the number of subsets of  $A$  is

- (A) 2
- (B) 3
- (C) 4
- (D) 8

12. In which of the following Venn diagrams is the region  $A \cap B'$  shaded?

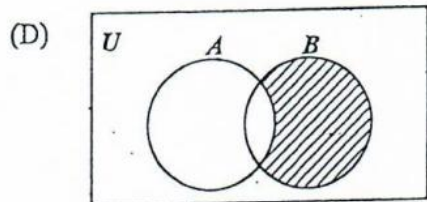
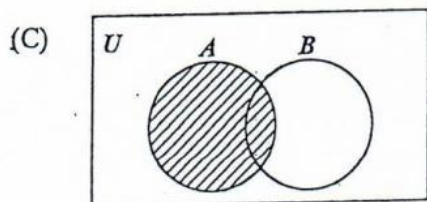
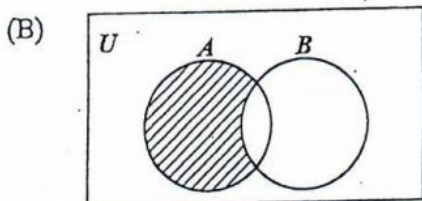
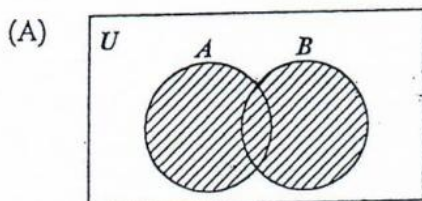

13. If the universal set  $U = \{1, 2, 3, 4, 5, 6\}$  and  $H = \{3, 4, 6\}$ , then  $H' =$

- (A)  $\{3, 4, 6\}$
- (B)  $\{1, 3, 5\}$
- (C)  $\{2, 4, 6\}$
- (D)  $\{1, 2, 5\}$

Item 14 refers to the following Venn diagram.

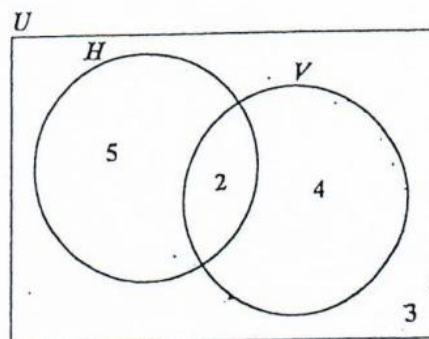

14. In the Venn diagram

- $U = \{\text{students who play games}\}$
- $H = \{\text{students who play hockey}\}$
- $V = \{\text{students who play volleyball}\}$

The number of students in each set is indicated. How many students do NOT play volleyball?

- (A) 2
- (B) 3
- (C) 5
- (D) 8

15. The simple interest on \$600 for 4 years at 5 per cent per annum is

(A)  $\frac{\$600 \times 5 \times 4}{100}$

(B)  $\frac{\$100 \times 5 \times 4}{600}$

(C)  $\frac{\$600 \times 5}{100 \times 4}$

(D)  $\frac{\$100 \times 4}{600 \times 5}$

16.  $3\frac{1}{4}\%$  of \$500 is
- (A) \$ 1.62  
(B) \$15.52  
(C) \$16.00  
(D) \$16.25
17. Mrs Jones has US\$200 to change to TT\$. The bank gives her TT\$6.20 for US\$1 and charges TT\$2.50 for the transaction. Mrs Jones receives
- (A) TT\$1 237.50  
(B) TT\$1 238.50  
(C) TT\$1 240.00  
(D) TT\$1 242.50
18. A man's basic wage for a 40-hour week is \$160.00. He is paid \$5.00 per hour for overtime. If he works  $6\frac{1}{2}$  hours overtime in a certain week, his wage for that week is
- (A) \$165.00  
(B) \$166.50  
(C) \$171.50  
(D) \$192.50
19. A dinner at a restaurant was advertised at \$60 plus 18% tax. The TOTAL bill for this dinner was
- (A) \$60.00  
(B) \$70.80  
(C) \$78.00  
(D) \$81.60
20. A store offers a discount of 10% to customers who spend more than \$20. If a customer's total bill is \$80, what will he actually pay?
- (A) \$60  
(B) \$70  
(C) \$72  
(D) \$74
21. A salesman sells a car for \$10 500. If he is paid a commission of 5% for the first \$10 000 and 8% on the remainder, then the TOTAL commission he receives is
- (A) \$525  
(B) \$540  
(C) \$545  
(D) \$565
22. Mr Jones buys a car for \$64 000. The car depreciates by 20% in the first year and 10% in each of the following years. The value of the car at the end of the second year is
- (A) \$19 200  
(B) \$44 800  
(C) \$46 080  
(D) \$51 200
23.  $15p + 55q - 2(3p + 4q) =$
- (A)  $9p + 47q$   
(B)  $9p + 63q$   
(C)  $21p + 63q$   
(D)  $70p - 14q$
24.  $-(-2q) - 3q =$
- (A)  $-6q$   
(B)  $-5q$   
(C)  $-q$   
(D)  $5q$

25.  $2^6 \div 2^2 =$

- (A)  $2^3$   
 (B)  $2^4$   
 (C)  $2^8$   
 (D)  $2^{12}$

26. If  $\frac{p}{5} = 20$ , then  $p =$

- (A)  $20 - 5$   
 (B)  $20 + 5$   
 (C)  $20 \div 5$   
 (D)  $20 \times 5$

27. "When 7 is added to 3 times a certain number,  $n$ , the result is 22."

The statement above may be represented by the equation

- (A)  $7n - 22 = 3$   
 (B)  $3n + 22 = 7$   
 (C)  $3n + 7 = 22$   
 (D)  $7n + 3 = 22$

28. Thirty-six men can paint a shopping mall in 25 days. How many days will it take 15 men to paint the mall, if they work at the same rate?

- (A) 50  
 (B) 56  
 (C) 60  
 (D) 72

29. If  $x = 4$  and  $y = 2$ , then the value of

$$\frac{x^2 + 3y}{xy} \text{ is}$$

- (A)  $1\frac{3}{4}$   
 (B)  $2\frac{1}{2}$   
 (C)  $2\frac{3}{8}$   
 (D)  $2\frac{3}{4}$

Item 30 refers to the following diagram of a trapezium.

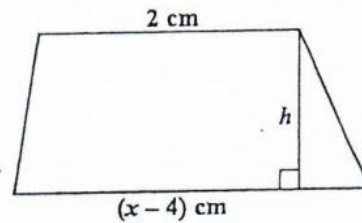
30. The trapezium with height,  $h$ , has an area of  $x^2 \text{ cm}^2$ . The equation that may be used to find the value of  $x$  is

- (A)  $x^2 = \frac{h}{2}(x - 2)$   
 (B)  $x^2 = h(x - 1)$   
 (C)  $x^2 = \frac{h}{2}(x - 6)$   
 (D)  $x^2 = h(x - 4)(x + 2)$

31. Given that  $3(x-1) - 2(x-1) = 7$ , the value of  $x$  is

(A) 6  
 (B) 7  
 (C) 8  
 (D) 9

Item 32 refers to the following diagram of a circle.

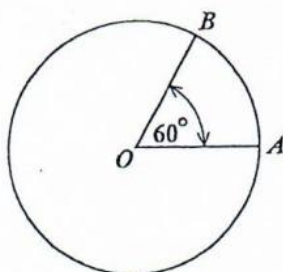

32. In the circle above, with centre  $O$ , the area is  $20 \text{ cm}^2$ . The area of the minor sector  $AOB$ , in  $\text{cm}^2$ , is

(A)  $\frac{60}{360} \times 20$   
 (B)  $\frac{120}{360} \times 20$   
 (C)  $\frac{60}{360} \times 20 \times 20$   
 (D)  $\frac{120}{360} \times 20 \times 20$

33. 2 500 millimetres expressed in metres is

(A) 0.25  
 (B) 2.5  
 (C) 25  
 (D) 250

Item 34 refers to the following diagram which shows a cylinder with diameter 6 cm and height 20 cm.

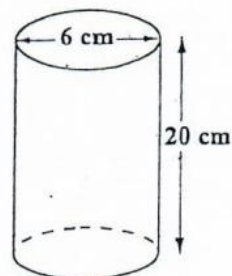

34. The volume, in  $\text{cm}^3$ , of the cylinder is

(A)  $180\pi$   
 (B)  $240\pi$   
 (C)  $360\pi$   
 (D)  $720\pi$

35. The distance around the edge of a circular pond is 88 m. The radius, in metres, is

(A)  $88\pi$   
 (B)  $176\pi$   
 (C)  $\frac{88}{\pi}$   
 (D)  $\frac{44}{\pi}$

36. An aircraft leaves  $A$  at 16:00 hours and arrives at  $B$  at 19:30 hours, travelling at an average speed of 550 kilometres per hour.  $A$  and  $B$  are in the same time zone. The distance from  $A$  to  $B$ , in kilometres, is

(A) 907.5  
 (B) 962.5  
 (C) 1815  
 (D) 1925

Item 37 refers to the following diagram, not drawn to scale, which shows a cuboid.

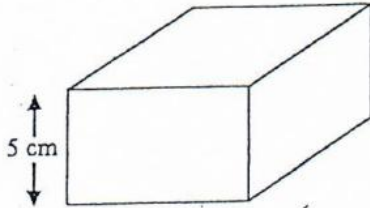

37. The volume of the cuboid is  $320 \text{ cm}^3$  and the height is 5 cm. If the cuboid has a square base, what is the length of one side of the base?
- (A) 8 cm  
(B) 16 cm  
(C) 32 cm  
(D) 64 cm
38. A square has the same area as a rectangle with sides of length 9 cm and 16 cm. What is the length of the side of the square?
- (A) 9 cm  
(B) 12 cm  
(C) 12.5 cm  
(D) 75 cm
39. The distance around a lake is 8 km. On a map, this distance around the lake is represented by a length of 2 cm. The scale on the map is
- (A) 1 : 40  
(B) 1 : 2 000  
(C) 1 : 200 000  
(D) 1 : 400 000

40. The median of the numbers 1, 1, 5, 5, 6, 7, 7, 7, 7, 8 is

(A) 7  
(B) 6.5  
(C) 6  
(D) 5.4

Item 41 refers to the following table which shows the frequency of scores obtained by students in a test.

Scores	2	3	5	6	8	11
Students	8	4	6	3	12	2

41. The modal score is

(A) 8  
(B) 9  
(C) 10  
(D) 12

42. The heights, in cm, of 10 students are 150, 152, 155, 153, 170, 160, 156, 165, 158, 155. The range is

(A) 5  
(B) 20  
(C) 150  
(D) 155

Item 43 refers to the following bar chart which shows the ages of children who took part in a survey.

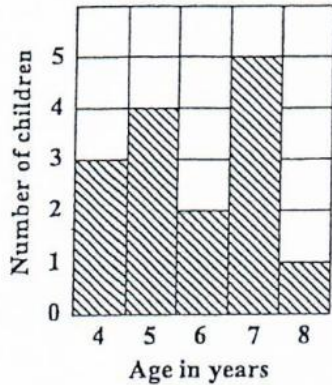

43. How many children took part in the survey?

- (A) 5
- (B) 15
- (C) 75
- (D) 87

44. Six hundred students write an examination. The probability of a randomly selected student failing the examination is  $\frac{1}{5}$ .

How many students are expected to pass?

- (A) 100
- (B) 120
- (C) 480
- (D) 500

Item 45 refers to the following piechart which shows the drinks preferred by a group of students.  $AOC$  is a diameter of the circle.

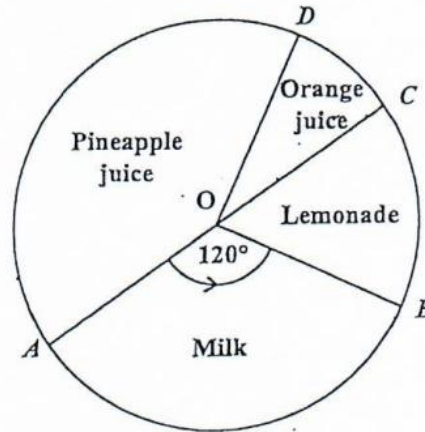

45. If 12 students prefer lemonade, then the TOTAL number of students is

- (A) 48
- (B) 72
- (C) 180
- (D) 360

Item 46 refers to the following mapping diagram.

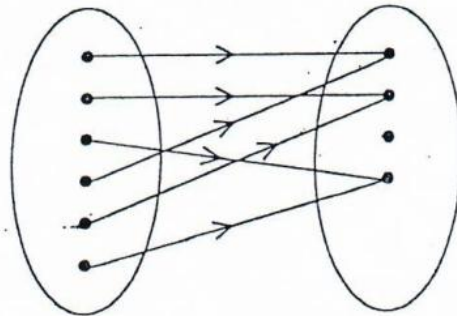

46. The relationship that BEST describes the mapping in the diagram is

- (A) one-to-one
- (B) one-to-many
- (C) many-to-one
- (D) many-to-many

47. Which of the following line graphs represents  $\{x : -2 < x \leq 4\}$ ?

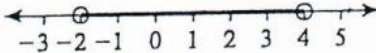
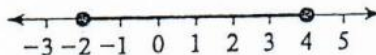
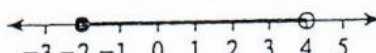
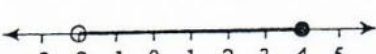
- (A) 
- (B) 
- (C) 
- (D) 

Items 48–49 refer to the following graph of a quadratic function.

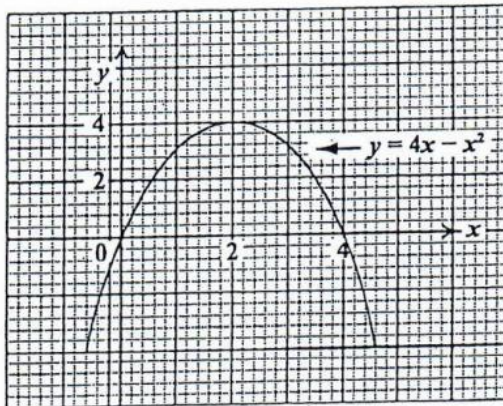

48. The maximum point of  $y = 4x - x^2$  is

- (A) (0, 0)  
 (B) (0, 4)  
 (C) (2, 4)  
 (D) (4, 2)

49. The values of  $x$  at the points where  $y = 4x - x^2$  intersects  $y = 0$  are

- (A)  $x = 0$  and  $x = 4$   
 (B)  $x = 0$  and  $x = 2$   
 (C)  $x = 2$  and  $x = 4$   
 (D)  $x = 0$  and  $x = -4$

Item 50 refers to the following mapping diagram.

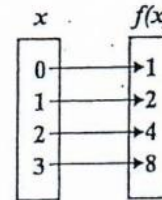

50. The diagram represents the mapping

- (A)  $f(x) : x \rightarrow x + 2$   
 (B)  $f(x) : x \rightarrow x + 1$   
 (C)  $f(x) : x \rightarrow 2^x$   
 (D)  $f(x) : x \rightarrow 2x$

51. Which of the following sets is represented by the function  $f : x \rightarrow x^2 + 3$  where

$$x \in \{0, 1, 2, 3\}?$$

- (A)  $\{(0, 3), (1, 1), (2, 4), (3, 9)\}$   
 (B)  $\{(0, 3), (1, 4), (2, 5), (3, 6)\}$   
 (C)  $\{(0, 3), (1, 5), (2, 7), (3, 9)\}$   
 (D)  $\{(0, 3), (1, 4), (2, 7), (3, 12)\}$

Item 52 refers to the following transversal diagram.

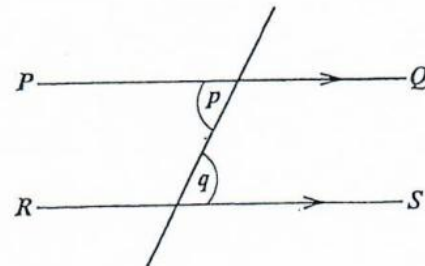

52. In the diagram  $PQ$  and  $RS$  are parallel. Which of the following BEST describes the relation between  $p$  and  $q$ ?

- (A)  $p = q$   
 (B)  $p < q$   
 (C)  $p + q = 90^\circ$   
 (D)  $p + q = 180^\circ$

Item 53 refers to the following diagram which shows a translation.

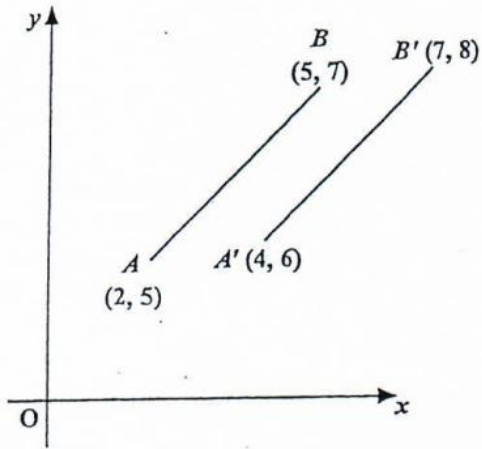

53. In the diagram, the translation by which  $AB$  is mapped onto  $A'B'$  is represented by

- (A)  $\begin{bmatrix} 1 \\ 1 \end{bmatrix}$
- (B)  $\begin{bmatrix} 2 \\ 1 \end{bmatrix}$
- (C)  $\begin{bmatrix} 3 \\ 2 \end{bmatrix}$
- (D)  $\begin{bmatrix} 5 \\ 3 \end{bmatrix}$

Item 54 refers to the following diagram of a circle.

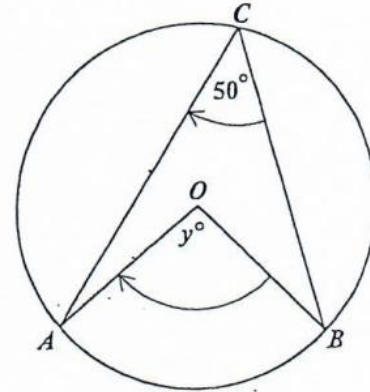

54. If  $O$  is the centre of the circle, then  $y^\circ$  is

- (A)  $25^\circ$
- (B)  $80^\circ$
- (C)  $90^\circ$
- (D)  $100^\circ$

55. A ship sailed 8 km due east from  $A$  to  $B$ . It then sailed 6 km due north to  $C$ . Which of the following diagrams BEST represents the path of the ship?

(A)

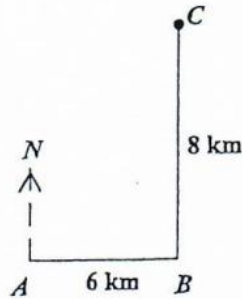

(B)

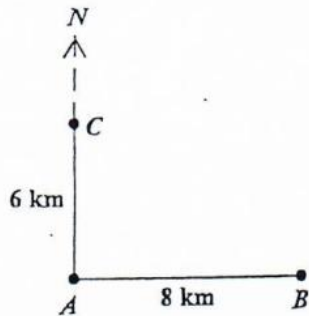

(C)

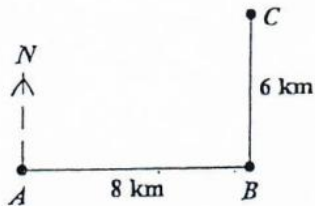

(D)

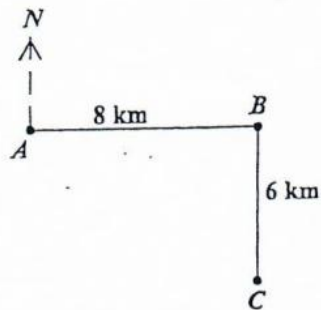

Item 56 refers to the following diagram which shows a transformation.

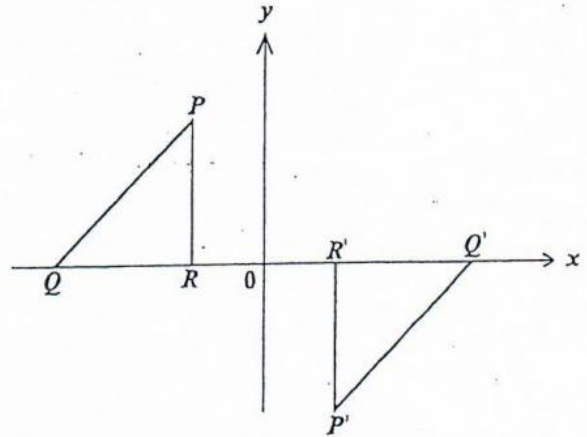

56. The transformation which will map triangle  $PQR$  onto  $P'Q'R'$  is

- (A) a rotation of  $180^\circ$  about the origin
- (B) a reflection in the line  $y = x$
- (C) an enlargement, centre  $R$ , of scale factor  $-1$
- (D) a translation parallel to the  $x$ -axis

Item 57 refers to the following diagram.

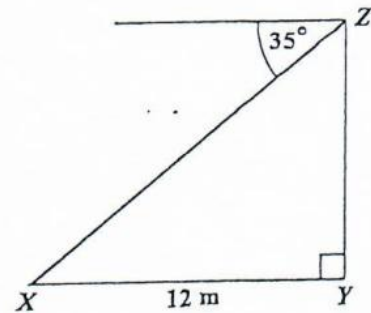

57. The diagram, not drawn to scale, shows that the angle of depression of point  $X$  from  $Z$  is  $35^\circ$ . If  $X$  is 12 metres from  $Y$ , the height  $YZ$ , in metres, is

- (A)  $12 \cos 35^\circ$
- (B)  $12 \sin 35^\circ$
- (C)  $12 \tan 35^\circ$
- (D)  $12 \cos 55^\circ$

Item 58 refers to the following diagram which shows an enlargement.

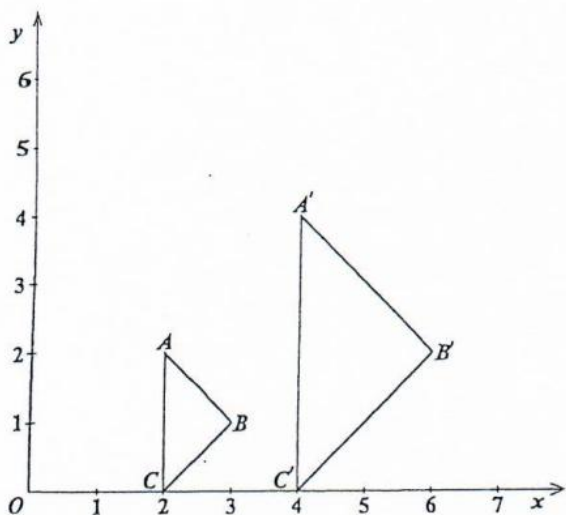

58. In the diagram, triangle  $ABC$  is mapped onto triangle  $A'B'C'$  where  $O$  is the centre of enlargement. What is the scale factor of the enlargement?

- (A)  $\frac{1}{2}$
- (B)  $-2$
- (C)  $-\frac{1}{2}$
- (D)  $2$

Item 59 refers to the following diagram of a triangle.

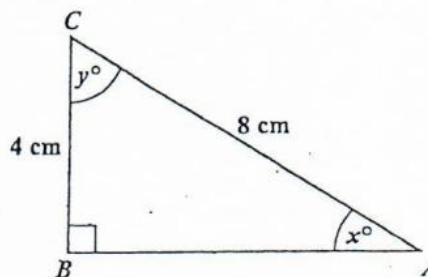

59. In the right-angled triangle above, which trigonometric ratio is equal to  $\frac{4}{8}$ ?

- (A)  $\sin x$
- (B)  $\tan y$
- (C)  $\cos x$
- (D)  $\tan x$

Item 60 refers to the following diagram.

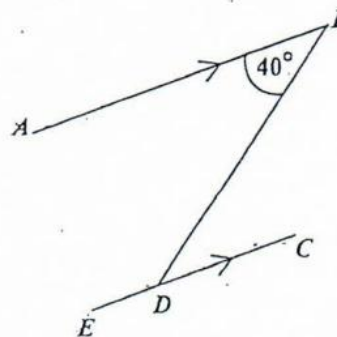

60. In the diagram above,  $AB$  is parallel to  $EC$ . The value of  $\angle BDE$  is

- (A)  $40^\circ$
- (B)  $50^\circ$
- (C)  $120^\circ$
- (D)  $140^\circ$

END OF TEST

IF YOU FINISH BEFORE TIME IS CALLED, CHECK YOUR WORK ON THIS TEST.



1. The number 3.14063 written correct to 3 decimal places is

- (A) 3.140
- (B) 3.141
- (C) 3.146
- (D) 3.150

2. What percentage of 40 is 8?

- (A) 5%
- (B) 20%
- (C) 32%
- (D) 150%

3. Using the distributive property

$$49 \times 17 + 49 \times 3 =$$

- (A)  $49 \times 20$
- (B)  $49 + 20$
- (C)  $52 \times 66$
- (D)  $52 + 66$

4. The next term in the sequence

1, 6, 13, 22, 33, \_\_\_\_\_ is

- (A) 44
- (B) 45
- (C) 46
- (D) 52

5. 0.45 written as a common fraction, in its simplest form, is

- (A)  $\frac{9}{20}$
- (B)  $\frac{4}{5}$
- (C)  $\frac{9}{10}$
- (D)  $\frac{5}{4}$

6. A certain amount of money is shared in the ratio 2:3:9. If the difference between the first and second shares is \$40, then the amount of money shared is

- (A) \$280
- (B) \$360
- (C) \$400
- (D) \$560

7. Which of the following sets is equivalent to  $\{a, b, c, d\}$ ?

- (A)  $\{4\}$
- (B)  $\{a, b, c\}$
- (C)  $\{p, q, r, s\}$
- (D)  $\{1, 2, 3, 4, 5\}$

Item 8 refers to the following Venn diagram.

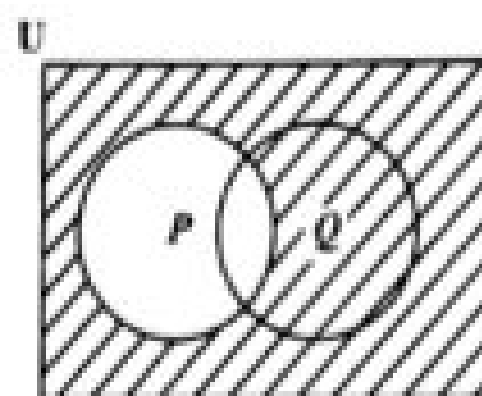

8. The shaded region represents

- (A)  $P'$
- (B)  $(PUQ)'$
- (C)  $PUQ'$
- (D)  $Q \cap P'$

GO ON TO THE NEXT PAGE

Item 9 refers to the following Venn diagram.

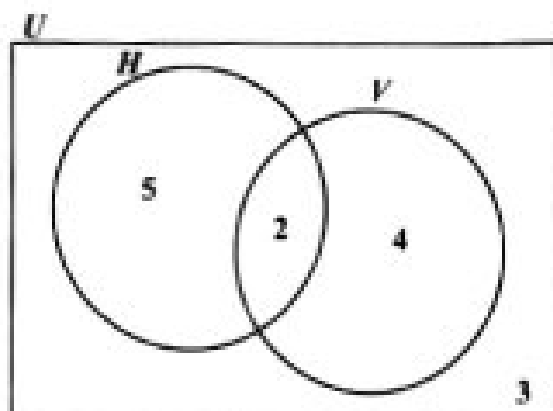

9. In the Venn diagram

- $U = \{\text{students who play games}\}$
- $H = \{\text{students who play hockey}\}$
- $V = \{\text{students who play volleyball}\}$

The number of students in each set is shown. How many students do NOT play volleyball?

- (A) 2
  - (B) 3
  - (C) 5
  - (D) 8
10. If  $Q = \{a, b, c\}$  how many subsets can be obtained from the set  $Q$ ?
- (A)  $2 + 3$
  - (B)  $2 \times 3$
  - (C)  $2^3$
  - (D)  $3^2$

Item 11 refers to the following information on the description of three sets.

- $P = \{\text{prime numbers}\}$
- $Q = \{\text{odd numbers}\}$
- $R = \{\text{even numbers}\}$

11. Which of the following sets is empty?

- (A)  $P \cap R$
- (B)  $P \cup Q$
- (C)  $P \cap Q$
- (D)  $Q \cap R$

12. If  $P$  and  $Q$  are two sets where  $n(P \cup Q) = 13$ ,  $n(P \cap Q) = 6$  and  $n(P) = 9$ , then  $n(Q) =$

- (A) 4
- (B) 10
- (C) 15
- (D) 22

13. A man's taxable income is \$20 000. He pays tax at the rate of 28%. The amount of income tax he pays is

- (A) \$3 825
- (B) \$4 800
- (C) \$5 600
- (D) \$7 200

14. A man's basic wage for a 40-hour week is \$160.00. He is paid \$5.00 per hour for overtime. If he works  $6 \frac{1}{2}$  hours overtime in a certain week, his wage for that week is

- (A) \$165.00
- (B) \$166.50
- (C) \$171.50
- (D) \$192.50

15. If TTS\$6.00 is equivalent to US\$1.00, then TTS\$15.00 in US dollars is
- (A) \$0.25  
(B) \$0.40  
(C) \$2.50  
(D) \$4.00
16. The annual interest rate on a 15-year mortgage on a house assessed at a value of \$450 000 is 5 cents on every \$1. What is the interest paid on the mortgage for the first year?
- (A) \$ 11 750  
(B) \$ 22 500  
(C) \$107 500  
(D) \$117 500
17. Mary invested \$200 for 5 years at 5% per annum. John invested \$500 at the same rate. If they both received the same amount of money in simple interest, for how many years did John invest his money?
- (A) 2  
(B)  $2\frac{1}{2}$   
(C) 3  
(D) 5
18. A salesman sells a car for \$11 000. If he is paid a commission of 4.5% for the first \$10 000 and 7.5% on the remainder, then the commission he receives is
- (A) \$ 495  
(B) \$ 525  
(C) \$ 825  
(D) \$1 320
19. A television set costs \$350 cash. When bought on hire-purchase, a deposit of \$35 is required, followed by 12 monthly payments of \$30. How much is saved by paying cash?
- (A) \$10  
(B) \$25  
(C) \$40  
(D) \$45
20. Mr Jones bought a car for \$64 000. The car depreciates by 20% in the first year and 10% in each of the following years. The value of the car at the end of the second year was
- (A) \$19 200  
(B) \$44 800  
(C) \$46 080  
(D) \$51 200
21.  $\frac{1}{5x} + \frac{2}{3x} =$
- (A)  $\frac{3}{8x^2}$   
(B)  $\frac{3}{8x}$   
(C)  $\frac{13}{15x^2}$   
(D)  $\frac{13}{15x}$

22. If  $5(2x - 1) = 35$ , then  $x =$

- (A)  $-4$
- (B)  $\frac{1}{4}$
- (C)  $3$
- (D)  $4$

23.  $3x^2 \times 2x^2 =$

- (A)  $6x^2$
- (B)  $5x^2$
- (C)  $6x^4$
- (D)  $72x^2$

24. Given that  $3 * 6 = 12$  and  $2 * 5 = 9$ , then  $a * b$  may be defined as

- (A)  $4(b - a)$
- (B)  $a^2 - b$
- (C)  $6a - b$
- (D)  $2a + b$

25. When 8 is subtracted from a certain number and the result is multiplied by 3 the answer is 21. What is the original number?

- (A) 1
- (B) 3
- (C) 10
- (D) 15

26. If  $x = -2$ ,  $y = 3$ ,  $r = 2$ , then  $\left(\frac{x}{y}\right)^r =$

- (A)  $\frac{1}{9}$
- (B)  $\frac{4}{9}$
- (C)  $\frac{4}{3}$
- (D)  $\frac{9}{4}$

Items 27–28 refer to the following two matrices,  $P$  and  $Q$ .

$$P = \begin{bmatrix} 8 & 6 \\ 7 & 5 \end{bmatrix} \quad Q = \begin{bmatrix} 1 & 2 & 3 & 4 \\ 12 & 3 & 4 & 1 \\ 13 & 14 & 1 & 2 \end{bmatrix}$$

27. What is the order of Matrix  $Q$ ?

- (A)  $3 \times 4$
- (B)  $3 \times 2$
- (C)  $2 \times 3$
- (D)  $4 \times 3$

28. The determinant of  $P$ ,  $|P|$ , is

- (A) 2
- (B)  $-2$
- (C)  $-13$
- (D) 26

29. If the vectors  $\mathbf{p}$  and  $\mathbf{q}$  are  $\begin{bmatrix} 3 \\ 2 \end{bmatrix}$  and  $\begin{bmatrix} -1 \\ 4 \end{bmatrix}$  respectively, then  $\mathbf{p} - 2\mathbf{q}$  is

- (A)  $\begin{bmatrix} 5 \\ -6 \end{bmatrix}$
- (B)  $\begin{bmatrix} 1 \\ -6 \end{bmatrix}$
- (C)  $\begin{bmatrix} 5 \\ 10 \end{bmatrix}$
- (D)  $\begin{bmatrix} 1 \\ 10 \end{bmatrix}$

Item 30 refers to the following parallelogram,  $WXYZ$ . In the parallelogram,  $R$  is the midpoint of  $XY$ .

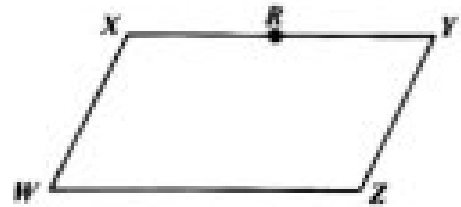

30. Based on the information above,  $\overrightarrow{ZR} =$

- (A)  $\overrightarrow{WX} - \frac{1}{2}\overrightarrow{WZ}$
- (B)  $\frac{1}{2}\overrightarrow{WZ} - \overrightarrow{WX}$
- (C)  $\overrightarrow{WX} + \frac{1}{2}\overrightarrow{WZ}$
- (D)  $-\frac{1}{2}\overrightarrow{WZ} - \overrightarrow{WX}$

Item 31 refers to the following diagrams of a square and a rectangle.

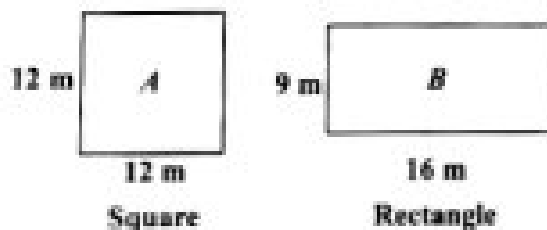

31. Which of the following statements is true about the perimeter of the square and the rectangle?

- (A) Perimeter of  $A =$  Perimeter of  $B$
- (B) Perimeter of  $A >$  Perimeter of  $B$
- (C) Perimeter of  $A \geq$  Perimeter of  $B$
- (D) Perimeter of  $A <$  Perimeter of  $B$

32. 3 800 millimetres expressed in metres is

- (A) 0.38
- (B) 3.8
- (C) 38
- (D) 380

33. The distance around the edge of a circular pond is 88 metres. The radius, in metres, is

- (A)  $88\pi$
- (B)  $176\pi$
- (C)  $\frac{88}{\pi}$
- (D)  $\frac{88}{2\pi}$

Item 34 refers to the following figure which shows a triangle resting on a square.

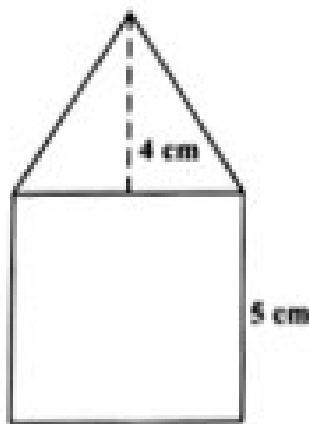

34. The length of one side of the square is 5 cm and the height of the triangle is 4 cm. What is the TOTAL area of the figure, in  $\text{cm}^2$ ?

- (A) 35
- (B) 45
- (C) 50
- (D) 100

35. The volume, in  $\text{cm}^3$ , of a cube of edge 3 cm is

- (A) 9
- (B) 18
- (C) 27
- (D) 54

36. The area of a rectangle is  $53.6 \text{ cm}^2$ . If the length is multiplied by four and the width is halved, the area would then be

- (A)  $26.8 \text{ cm}^2$
- (B)  $53.6 \text{ cm}^2$
- (C)  $107.2 \text{ cm}^2$
- (D)  $214.4 \text{ cm}^2$

37. On leaving Trinidad, the time on a pilot's watch was 23:00 h. When he arrived at his destination in the same time zone on the next day, his watch showed 03:00 h. How many hours did the flight take?

- (A) 4
- (B) 16
- (C) 20
- (D) 26

Item 38 refers to the following diagram of a trapezium.

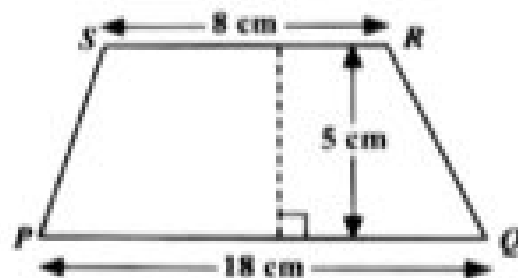

38. The area of the trapezium  $PQRS$  above is

- (A)  $45 \text{ cm}^2$
- (B)  $65 \text{ cm}^2$
- (C)  $90 \text{ cm}^2$
- (D)  $130 \text{ cm}^2$

GO ON TO THE NEXT PAGE

Items 39–40 refer to the following histogram which shows the number of children aged 4, 5, 6, 7 and 8 who took part in a survey.

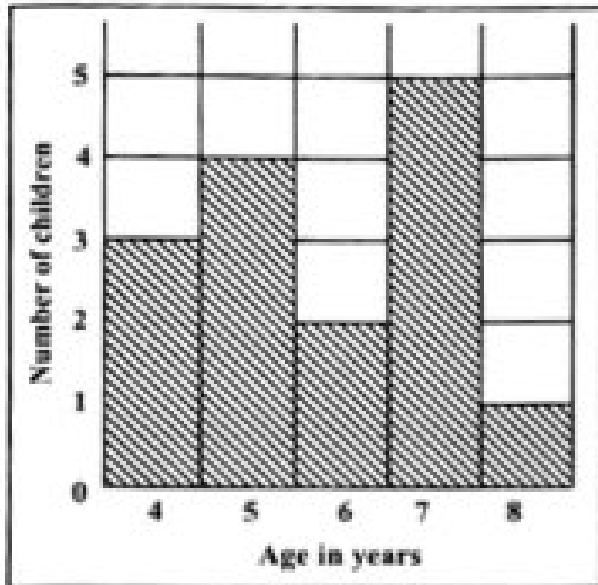

39. What was the modal age?

- (A) 5
- (B) 6
- (C) 7
- (D) 8

40. How many children took part in the survey?

- (A) 5
- (B) 15
- (C) 75
- (D) 87

41. The median of the numbers

1, 1, 5, 5, 6, 7, 7, 7, 7, 8 is

- (A) 7
- (B) 6.5
- (C) 6
- (D) 5.4

42. When three coins are tossed simultaneously, the possible outcomes are {HHH, HHT, HTH, HTT, THH, THT, TTH, TTT}, where H represents a head and T represents a tail.

What is the probability of randomly obtaining at LEAST TWO heads?

- (A)  $\frac{1}{4}$
- (B)  $\frac{3}{8}$
- (C)  $\frac{1}{2}$
- (D)  $\frac{2}{3}$

43. Six hundred students write an examination. The probability of a randomly selected student failing the examination is  $\frac{1}{5}$ .

How many students are expected to pass?

- (A) 120
- (B) 480
- (C) 500
- (D) 600

Item 44 refers to the following diagram, which shows the cumulative frequency polygon of the lengths, in metres, of 20 fish that are caught by two fishermen.

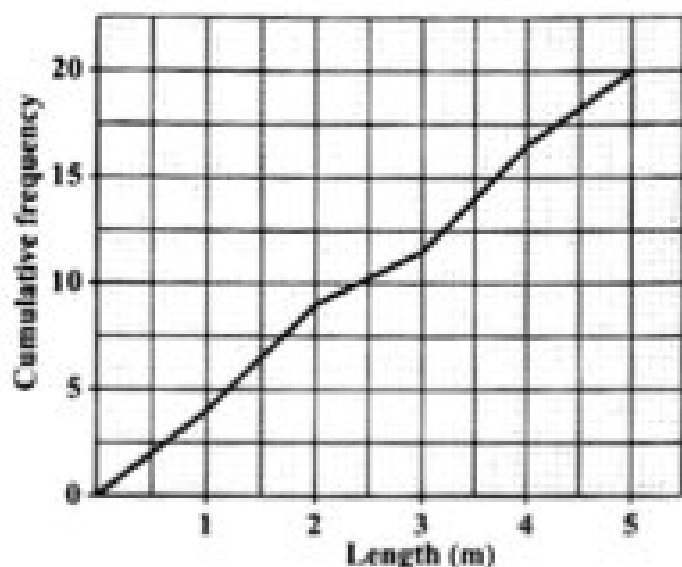

44. The interquartile range of the lengths of the fish is

- (A) 1.2 m
- (B) 2.1 m
- (C) 2.5 m
- (D) 3.7 m

45. Which of the following diagrams BEST illustrates a function?

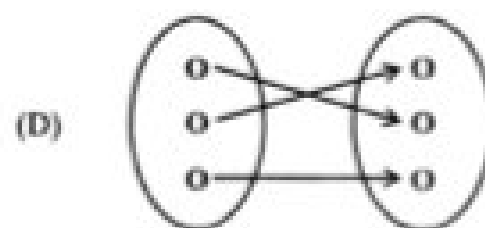
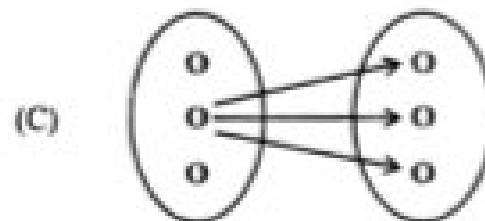
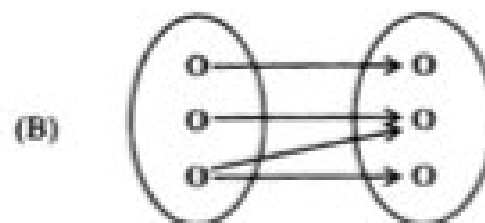
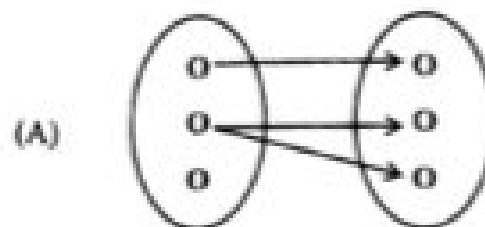

46. The equation of the line which passes through the point (0, 5) and has a gradient of 4 is

- (A)  $y = 4x$
- (B)  $y = 5x$
- (C)  $y = 4x + 5$
- (D)  $y = 5x + 4$

**Item 47** refers to the following diagram of a number line.



47. The graph of the inequality in the diagram is defined by

- (A)  $x < 1$
- (B)  $x > 1$
- (C)  $x \geq 1$
- (D)  $x \leq 1$

**Item 48** refers to the following graph of a straight line.

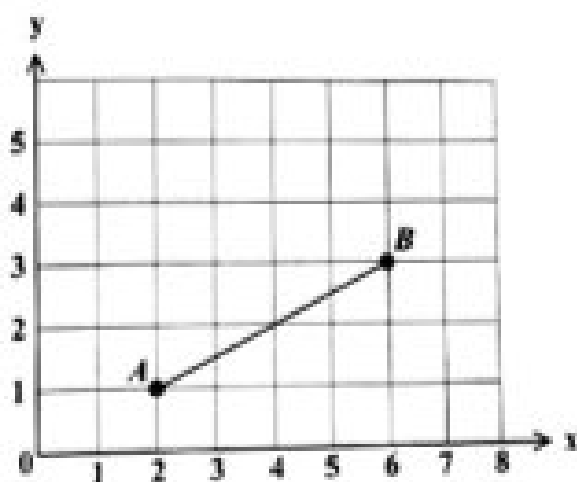

48. The gradient of  $AB$  in the graph above is

- (A)  $-2$
- (B)  $2$
- (C)  $-\frac{1}{2}$
- (D)  $\frac{1}{2}$

49. If  $f(x) = 2x^2 - 1$ , then  $f(-3) =$

- (A)  $-32$
- (B)  $-19$
- (C)  $17$
- (D)  $35$

**Item 50** refers to the following graph of a quadratic function.

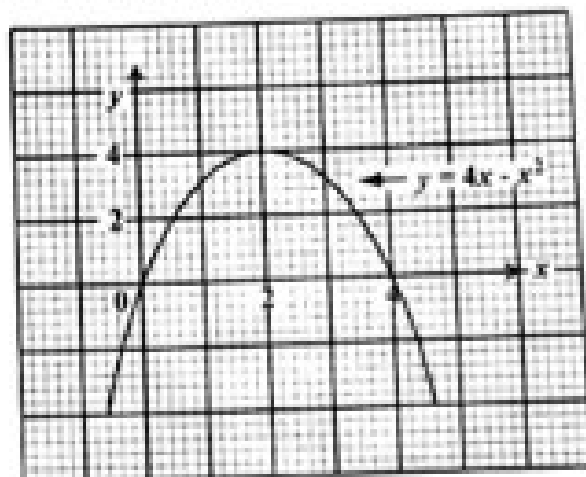

50. The maximum point of  $y = 4x - x^2$  is

- (A)  $(4, 4)$
- (B)  $(0, 4)$
- (C)  $(4, 2)$
- (D)  $(2, 4)$

51. What is the gradient of the straight line  $2y = -3x - 8$ ?

- (A)  $-3$
- (B)  $-\frac{3}{2}$
- (C)  $2$
- (D)  $3$

Item 52 refers to the following arrow diagram which shows a function,  $f$ .

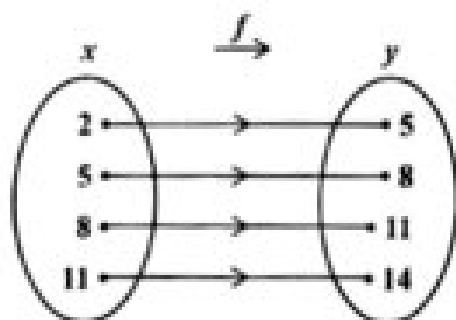

52. Which of the following BEST describes the function?

- (A)  $y = x + 3$
- (B)  $x + y = 3$
- (C)  $x = y + 3$
- (D)  $y = 2x + 1$

53. If each exterior angle of a regular polygon is  $60^\circ$ , then the polygon is a

- (A) quadrilateral
- (B) pentagon
- (C) hexagon
- (D) triangle

Item 54 refers to the following diagram.

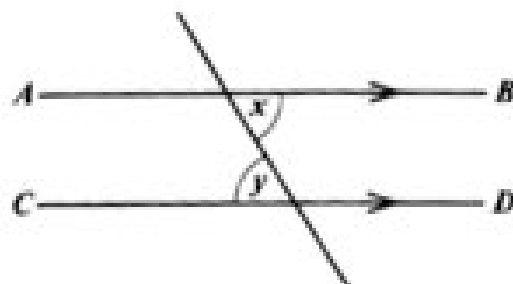

54. In the diagram,  $AB$  and  $CD$  are parallel. Which of the following BEST describes the relation between  $x$  and  $y$ ?

- (A)  $x = y$
- (B)  $x > y$
- (C)  $x + y > 2x$
- (D)  $x + y < 2x$

Item 55 refers to the following diagram of an isosceles triangle.



55. In the triangle, the value of  $x$  is

- (A)  $30^\circ$
- (B)  $60^\circ$
- (C)  $120^\circ$
- (D)  $150^\circ$

56. The image of a point  $P(-2, 3)$  under a translation  $\begin{pmatrix} 3 \\ 4 \end{pmatrix}$  is

- (A)  $(-6, 12)$
- (B)  $(-5, -1)$
- (C)  $(5, 1)$
- (D)  $(1, 7)$

Item 57 refers to the following diagram of two straight lines.

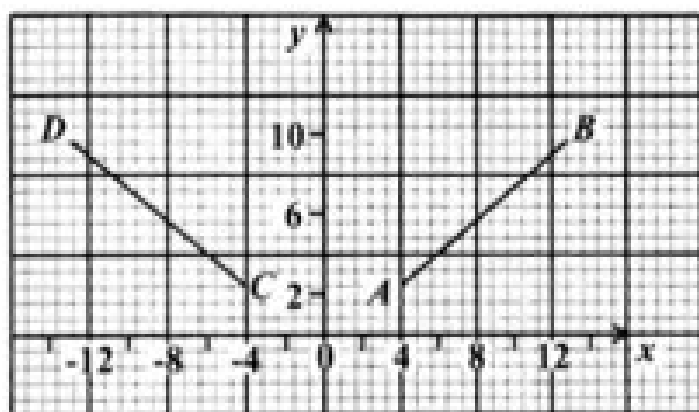

57. In the diagram above, the line  $CD$  is the image of  $AB$  after

- (A) a rotation through  $90^\circ$  centre  $O$
- (B) a reflection in the  $y$ -axis
- (C) a translation by vector  $\begin{pmatrix} -4 \\ -8 \end{pmatrix}$
- (D) a reflection in the  $x$ -axis

Item 58 refers to the following pair of similar triangles.

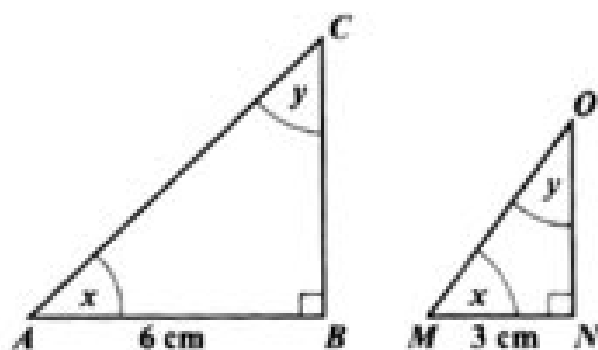

58. If the area of  $\Delta ABC$  is  $20 \text{ cm}^2$ , what is the area of  $\Delta MNO$ , in  $\text{cm}^2$ ?

- (A) 2.5
- (B) 3.3
- (C) 5
- (D) 10

**Item 59** refers to the following diagram which shows an enlargement.

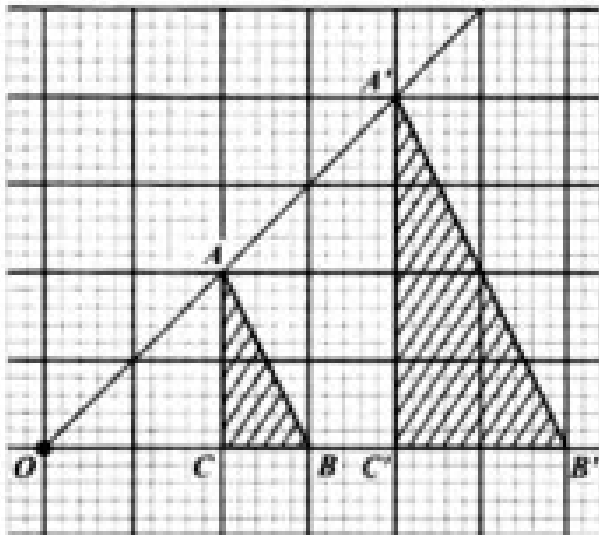

59.  $OAA'$ ,  $OBB'$  and  $OCC'$  are straight lines.  $\Delta ABC$  is mapped onto  $\Delta A'B'C'$  by an enlargement with centre  $O$ . What is the scale factor of the enlargement?

- (A)  $\frac{1}{2}$
- (B)  $-\frac{1}{2}$
- (C) 2
- (D) -2

**Item 60** refers to the following diagram.

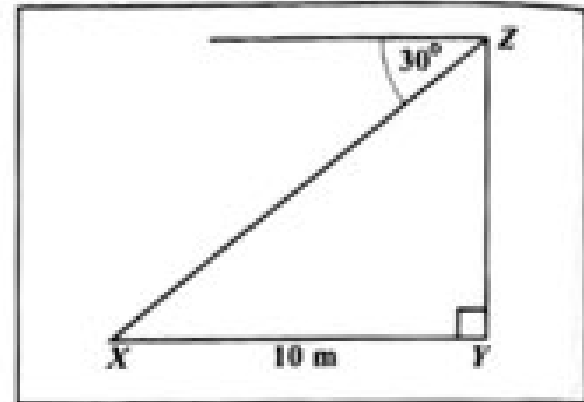

60. The diagram above, not drawn to scale, shows that the angle of depression of a point  $X$  from  $Z$  is  $30^\circ$ . If  $X$  is 10 metres from  $Y$ , the height of  $YZ$ , in metres, is

- (A)  $10 \tan 30^\circ$
- (B)  $10 \sin 30^\circ$
- (C)  $10 \cos 30^\circ$
- (D)  $10 \cos 60^\circ$

END OF TEST

IF YOU FINISH BEFORE TIME IS CALLED, CHECK YOUR WORK ON THIS TEST.



**CANDIDATE - PLEASE NOTE!**  
 PRINT your name on the line below and return this booklet with your answer sheet. Failure to do so may result in disqualification.

FORM TP 2019018

TEST CODE 01234010

JANUARY 2019

**CARIBBEAN EXAMINATIONS COUNCIL  
 CARIBBEAN SECONDARY EDUCATION CERTIFICATE®  
 EXAMINATION**

**MATHEMATICS**

Paper 01 – General Proficiency

1 hour 30 minutes

04 JANUARY 2019 (p.m.)

**READ THE FOLLOWING INSTRUCTIONS CAREFULLY.**

1. This test consists of 60 items. You will have 1 hour and 30 minutes to answer them.
2. In addition to this test booklet, you should have an answer sheet.
3. A list of formulae is provided on page 2 of this booklet.
4. Each item in this test has four suggested answers lettered (A), (B), (C), (D). Read each item you are about to answer, and decide which choice is best.
5. On your answer sheet, find the number which corresponds to your item and shade the space having the same letter as the answer you have chosen. Look at the sample item below.

Sample Item

$2a + 6a =$

- (A)  $8a$
- (B)  $8a^2$
- (C)  $12a$
- (D)  $12a^2$

Sample Answer

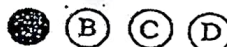

The best answer to this item is “8a”, so (A) has been shaded.

6. If you want to change your answer, erase it completely before you fill in your new choice.
7. When you are told to begin, turn the page and work as quickly and as carefully as you can. If you cannot answer an item, go on to the next one. You may return to that item later.
8. You may do any rough work in this booklet.
9. Figures are not necessarily drawn to scale.
10. Calculators and mathematical tables are NOT allowed for this paper.

**DO NOT TURN THIS PAGE UNTIL YOU ARE TOLD TO DO SO.**

1.  $\left(\frac{2}{3}\right)^2$  is equal to

- (A)  $\frac{4}{6}$
- (B)  $\frac{4}{3}$
- (C)  $\frac{2}{9}$
- (D)  $\frac{4}{9}$

2. The number 3.14063 written correct to 3 decimal places is

- (A) 3.140
- (B) 3.141
- (C) 3.146
- (D) 3.150

3. In standard notation, 208.06 is written as

- (A)  $2.0806 \times 10^2$
- (B)  $20.806 \times 10^1$
- (C)  $2.0806 \times 10^{-2}$
- (D)  $0.20806 \times 10^3$

4. If \$560 is shared in the ratio 2:3:9, the difference between the largest and the smallest shares is

- (A) \$ 80
- (B) \$240
- (C) \$280
- (D) \$360

5. If 60% of a number is 90, what is  $\frac{4}{5}$  of the number?

- (A) 54
- (B) 72
- (C) 120
- (D) 150

6. The first three common multiples of 3, 4 and 6 are

- (A) 0, 1, 2
- (B) 3, 4, 6
- (C) 6, 8, 12
- (D) 12, 24, 36

7. If  $P = \{2, 3, 5, 7\}$ ,  
 $Q = \{2, 3, 6\}$  and  
 $S = \{2, 4, 5\}$

then  $P \cap Q \cap S =$

- (A)  $\{2\}$
- (B)  $\{2, 3\}$
- (C)  $\{2, 3, 5\}$
- (D)  $\{2, 3, 4, 5, 6, 7\}$

Item 8 refers to the following Venn diagram.

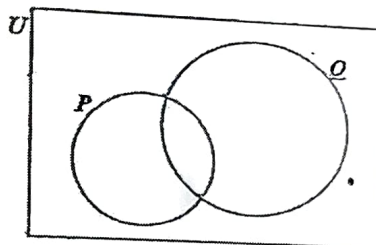

In the Venn diagram,  $n(P) = 5$ ,  $n(Q) = 9$  and  $n(P \cup Q) = 10$ .

8. What is  $n(Q \cap P)$ ?

- (A) 1
- (B) 4
- (C) 5
- (D) 9

GO ON TO THE NEXT PAGE

9. Which of the following sets is equivalent to the set  $\{p, q, r, s\}$ ?

- (A)  $\{4\}$
- (B)  $\{p, q, r\}$
- (C)  $\{a, b, c, d\}$
- (D)  $\{1, 2, 3, 4, 5\}$

10. All students in a class play Scrabble or Checkers or both. If 36% of the students play Scrabble only and 48% of the students play Checkers only, what percentage of students play BOTH games?

- (A) 12
- (B) 16
- (C) 84
- (D) 88

Item 11 refers to the following Venn diagram.

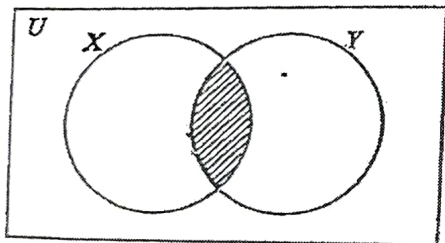

11. In the Venn diagram, X represents the set of factors of 12. Y represents the set of factors of 9. The shaded region represents the set of all factors of

- (A) 3
- (B) 6
- (C) 21
- (D) 108

Item 12 refers to the following Venn diagram.

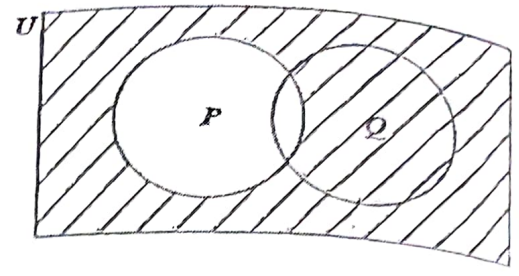

12. In the Venn diagram, the shaded area represents

- (A)  $P'$
- (B)  $(P \cup Q)'$
- (C)  $Q \cup P'$
- (D)  $Q \cap P'$

13. A store offers a discount of 15% on the total bill to customers who spend more than \$20. If a customer's total bill is \$80, how much must she pay?

- (A) \$60
- (B) \$65
- (C) \$68
- (D) \$71

14. At a store, sales tax is charged at a rate of 2% on the cost price of an item. The sales tax on a dress which costs \$180 is

- (A) \$ 3.60
- (B) \$ 10.80
- (C) \$176.40
- (D) \$183.60

846

A005

15. A plot of land is valued at \$18 000. Land tax of \$126 is charged annually. At what rate per annum is the land tax charged?

- (A) 0.07%
- (B) 0.7%
- (C) 7%
- (D) 70%

16. The exchange rate for one United States dollar (US\$1.00) is two dollars and seventy cents in Eastern Caribbean currency (EC\$2.70). What is the value of US\$4.50 in EC currency?

- (A) \$ 1.67
- (B) \$ 6.00
- (C) \$ 7.20
- (D) \$12.15

17. A man's annual salary is \$45 000. His tax free allowances total \$13 000. He has to pay a tax of 20% on his taxable income.

The tax payable is

- (A) \$ 2 600
- (B) \$ 6 400
- (C) \$ 9 000
- (D) \$11 600

18. A television set costs \$350 cash. When bought on hire purchase, a deposit of \$35 is required, followed by 12 monthly payments of \$30. How much is saved by paying cash?

- (A) \$10
- (B) \$25
- (C) \$40
- (D) \$45

19. A man pays 60 cents for every 200 m<sup>3</sup> of gas used, plus a fixed charge of \$13.75. How much does he pay when he uses 55 000 m<sup>3</sup> of gas?

- (A) \$178.75
- (B) \$175.25
- (C) \$165.00
- (D) \$151.25

Item 20 refers to the following table which shows the rates charged by an insurance company.

House Insurance	25¢ per \$100
Contents Insurance	50¢ per \$100

20. How much will a person pay for insurance, if his house is valued at \$50 000, and the contents at \$10 000?

- (A) \$175
- (B) \$225
- (C) \$450
- (D) \$500

21. The product of  $(-2a)$  and  $(-3a)$  is

- (A)  $-6a$
- (B)  $-5a$
- (C)  $5a^2$
- (D)  $6a^2$

GO ON TO THE NEXT PAGE

22. When 6 is added to a number and the sum is divided by 3, the result is 4. This statement written using mathematical symbols is

(A)  $\frac{6}{3} + x = 4$

(B)  $\frac{6+x}{3} = 4$

(C)  $\frac{6+x}{3} = \frac{4}{3}$

(D)  $6 + \frac{x}{3} = 4$

23. Althea normally saves \$x each month; but in June she saved \$4 more than twice her usual amount. In June she saved

(A) \$ 4x

(B) \$ 6x

(C) \$ (x + 4)

(D) \$ (2x + 4)

24. If  $3 + \frac{2}{x} = 1$ , the value of x is

(A) -1

(B)  $\frac{1}{5}$

(C)  $\frac{1}{2}$

(D) 5

25. If  $x = 4$  and  $y = 2$ , what is the value of  $\frac{x^2 + 3y}{xy}$ ?

(A)  $1\frac{3}{4}$

(B)  $2\frac{1}{2}$

(C)  $2\frac{3}{8}$

(D)  $2\frac{3}{4}$

26. The expression  $-2(x - 4)$  is the same as

(A)  $-2x - 8$

(B)  $-2x + 8$

(C)  $-2x - 4$

(D)  $-2x + 4$

27. If  $|A| = 0$ , then A is

(A) an inverse matrix

(B) a singular matrix

(C) an identity matrix

(D) a non-singular matrix

Item 28 refers to the following matrices, X and Y.

$$X = \begin{pmatrix} 1 & 3 & -3 \\ 3 & 0 & 5 \end{pmatrix}, \quad Y = \begin{pmatrix} 3 & 0 \\ 2 & 1 \\ 0 & 5 \end{pmatrix}$$

28. What is the order of the matrix product, XY?

(A)  $2 \times 2$

(B)  $2 \times 3$

(C)  $3 \times 2$

(D)  $3 \times 3$

If the vectors  $p$  and  $q$  are  $\begin{bmatrix} 3 \\ 2 \end{bmatrix}$  and  $\begin{bmatrix} -1 \\ 4 \end{bmatrix}$  respectively, then  $-p - 2q$  is

- (A)  $\begin{bmatrix} 5 \\ -6 \end{bmatrix}$   
 (B)  $\begin{bmatrix} -2 \\ -6 \end{bmatrix}$   
 (C)  $\begin{bmatrix} 5 \\ 10 \end{bmatrix}$   
 (D)  $\begin{bmatrix} -1 \\ -10 \end{bmatrix}$

Item 30 refers to the following parallelogram,  $WXYZ$ . In the parallelogram,  $R$  is the midpoint of  $XY$ .

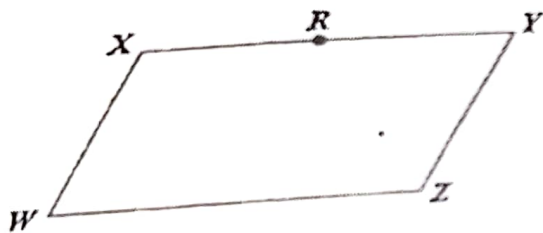

30. Based on the information above,  $\vec{ZR} =$

- (A)  $\vec{WX} + \frac{1}{2}\vec{WZ}$   
 (B)  $\vec{WX} - \frac{1}{2}\vec{WZ}$   
 (C)  $\frac{1}{2}\vec{WX} - \vec{WZ}$   
 (D)  $\frac{1}{2}\vec{WX} + \vec{WZ}$

31. If it took a speedboat 9 hours to travel a distance of 1 080 km, what was its average speed, in  $\text{kmh}^{-1}$ ?

- (A) 12  
 (B) 102  
 (C) 120  
 (D) 1200

Item 32 refers to the following diagram of a trapezium.

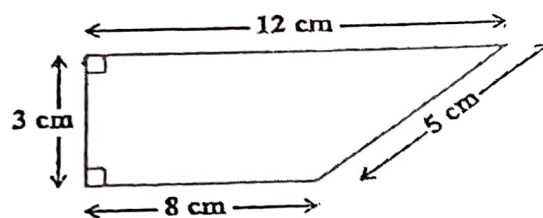

32. The area of the trapezium is

- (A)  $24 \text{ cm}^2$   
 (B)  $28 \text{ cm}^2$   
 (C)  $30 \text{ cm}^2$   
 (D)  $36 \text{ cm}^2$

GO ON TO THE NEXT PAGE

Item 33 refers to the following circle, with centre  $O$ .

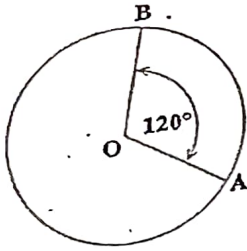

33. If the circumference of the circle is 15 cm, then the length of the minor arc  $AB$ , in cm, is

(A)  $\frac{360}{120} \times 15$

(B)  $\frac{120}{360} \times 15$

(C)  $\frac{360}{360 - 120} \times 15$

(D)  $\frac{360 - 120}{360} \times 15$

34. The lengths of the sides of a triangle are  $x$ ,  $2x$  and  $2x$  centimetres. If the perimeter is 20 centimetres, what is the value of  $x$ ?

- (A) 4
- (B) 5
- (C) 8
- (D) 10

35. A rectangular garden plot, 15 m long and 12 m wide, is used to plant fruits and vegetables. If  $80 \text{ m}^2$  of the plot is used to plant vegetables, what area of the plot is planted with fruits?

- (A)  $26 \text{ m}^2$
- (B)  $100 \text{ m}^2$
- (C)  $134 \text{ m}^2$
- (D)  $260 \text{ m}^2$

36. The distance around a lake is 8 km. On a map, this distance around the lake is represented by a length of 2 cm. The scale on the map is

- (A) 1:40
- (B) 1:2 000
- (C) 1:200 000
- (D) 1:400 000

Item 37 refers to the following diagram.

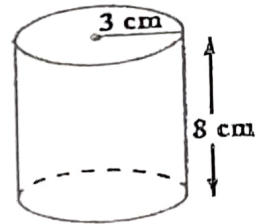

37. The diagram above, not drawn to scale, shows a cylinder of radius 3 cm and height 8 cm. The volume of the cylinder is

- (A)  $12 \pi \text{ cm}^3$
- (B)  $48 \pi \text{ cm}^3$
- (C)  $72 \pi \text{ cm}^3$
- (D)  $192 \pi \text{ cm}^3$

Item 38 refers to the following diagram, not drawn to scale, which shows a cuboid.

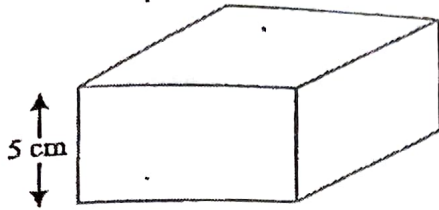

38. The volume of the cuboid is  $320 \text{ cm}^3$  and the height is 5 cm. If the cuboid has a square base, what is the length of one side of the base?

- (A) 8 cm
- (B) 16 cm
- (C) 32 cm
- (D) 64 cm

Item 39 refers to the following scores which were obtained by 11 students in a competition.

5, 3, 6, 8, 7, 8, 3, 11, 6, 3, 3

39. The modal score is

- (A) 3
- (B) 6
- (C) 8
- (D) 11

Item 40 refers to the following pie chart which shows the popular games played by 720 students.

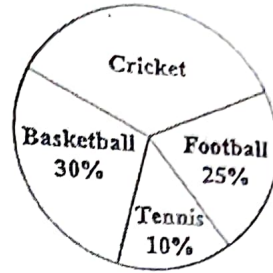

40. How many students play cricket?

- (A) 35
- (B) 120
- (C) 252
- (D) 300

GO ON TO THE NEXT PAGE

Items 41–42 refer to the following chart which shows the number of books 58 students bought at a sale.

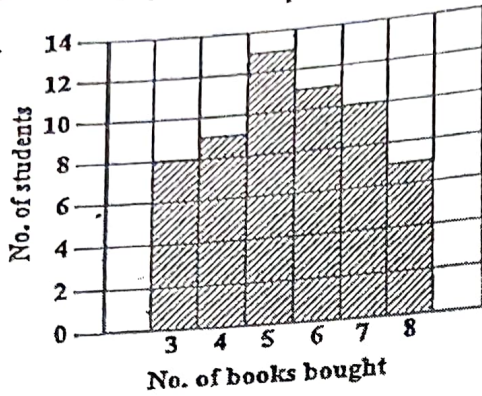

41. How many students bought exactly 4 books?

- (A) 8
- (B) 9
- (C) 10
- (D) 14

42. The median number of books bought by the students is

- (A) 5
- (B) 6
- (C) 29
- (D) 30

Items 43–44 refer to the following diagram, which shows the cumulative frequency polygon of the lengths, in metres, of 20 fish that were caught by two fishermen.

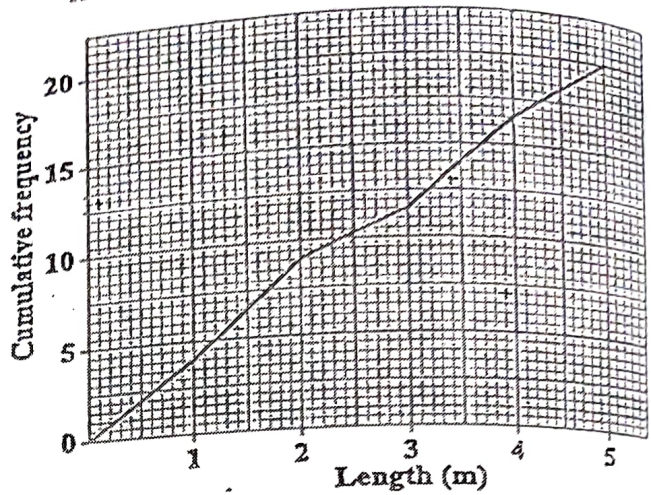

43. The semi-interquartile range of the lengths of the fish is

- (A) 1.20 m
- (B) 1.25 m
- (C) 2.5 m
- (D) 3.7 m

44. A fish is selected at random. What is the probability that it is at LEAST 1.8 m long?

- (A)  $\frac{5}{20}$
- (B)  $\frac{8}{20}$
- (C)  $\frac{12}{20}$
- (D)  $\frac{15}{20}$



Item 45 refers to the following arrow diagram.

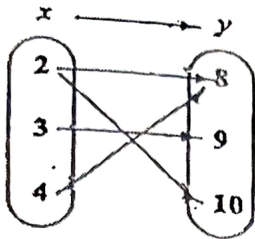

45. The arrow diagram above describes the relation

- (A)  $y$  is less than  $x$
- (B)  $y$  is a factor of  $x$
- (C)  $x$  is a factor of  $y$
- (D)  $x$  is a multiple of  $y$

46. Which of the following line graphs represents  $\{x : -2 < x \leq 4\}$ ?

- (A)
- (B)
- (C)
- (D)

47. Which of the following graphs represents a function?

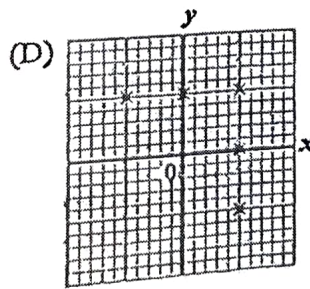
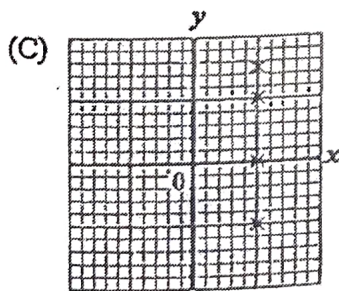
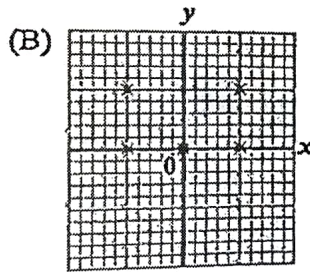
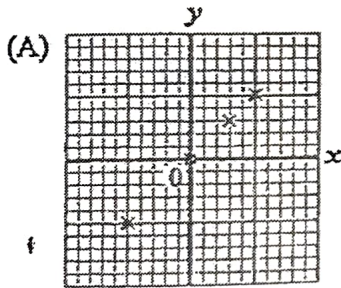

GO ON TO THE NEXT PAGE

48. Which of the following points lies on the line  $y = 2x - 3$ ?

- (A) (2, 3)
- (B) (-2, -1)
- (C) (4, 1)
- (D) (0, -3)

49. If  $f(x) = 2x^2 - 1$ , then  $f(-3) =$

- (A) -32
- (B) -19
- (C) 17
- (D) 35

Items 50-51 refer to the following graph.

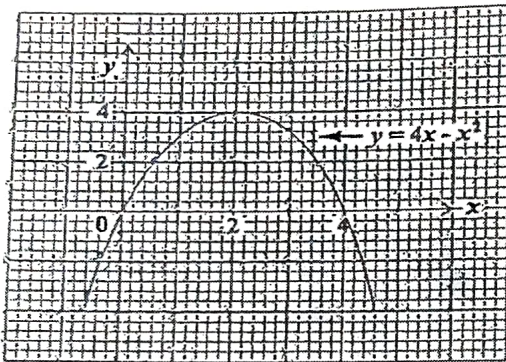

50. The maximum point of  $y = 4x - x^2$  is

- (A) (0, 0)
- (B) (0, 4)
- (C) (2, 4)
- (D) (4, 2)

51. The values of  $x$  at the points where  $y = 4x - x^2$  intersects  $y = 0$  are

- (A)  $x = 0$  and  $x = 4$
- (B)  $x = 0$  and  $x = 2$
- (C)  $x = 0$  and  $x = -4$
- (D)  $x = 2$  and  $x = 4$

52.

Which of the following sets is represented by the function  $f: x \rightarrow x^2 + 3$  where  $x \in \{0, 1, 2, 3\}$ ?

- (A)  $\{(0, 3), (1, 4), (2, 7), (3, 12)\}$
- (B)  $\{(0, 3), (1, 5), (2, 7), (3, 9)\}$
- (C)  $\{(0, 3), (1, 4), (2, 5), (3, 6)\}$
- (D)  $\{(0, 3), (1, 1), (2, 4), (3, 9)\}$

Item 53 refers to the following diagram.

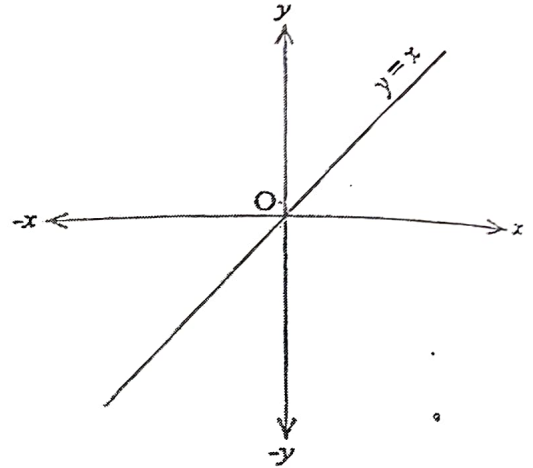

53. In the diagram above, if the line  $y = x$  is rotated anti-clockwise about  $O$  through  $90^\circ$ , what is its image?

- (A)  $y = 0$
- (B)  $x = 0$
- (C)  $y = x$
- (D)  $y = -x$

Questions 54-55 refer to the following diagram of a pair of intersecting lines.

AC and DE are straight lines intersecting at B. Angle DBA = 58°.

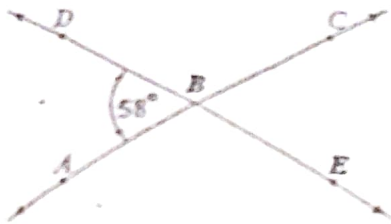

The measure of angle ABE is

- (A) 58°
- (B) 122°
- (C) 142°
- (D) 302°

Which of the following angles are equal?

- (A)  $\angle DBC$  and  $\angle CBE$
- (B)  $\angle CBE$  and  $\angle ABE$
- (C)  $\angle ABD$  and  $\angle CBD$
- (D)  $\angle ABD$  and  $\angle CBE$

56.

In each of the following diagrams, A' is the image of A. Which of the diagrams shows a reflection in the x-axis?

(A)

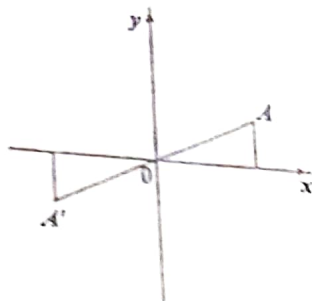

(B)

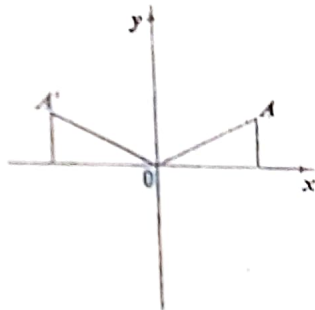

(C)

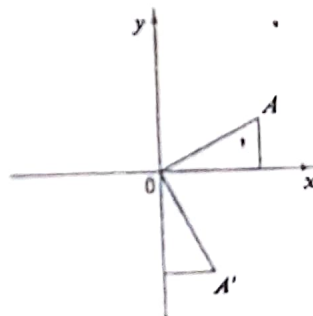

(D)

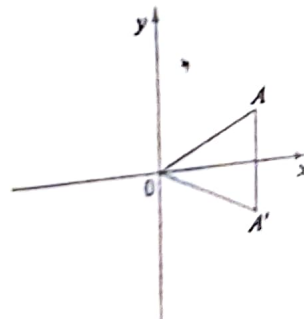

GO ON TO THE NEXT PAGE

57. In triangle  $ABC$ , angle  $A = x^\circ$  and angle  $B = 2x^\circ$ . What is the size of angle  $C$ ?

- (A)  $(180 - 3x)^\circ$
- (B)  $60^\circ$
- (C)  $30^\circ$
- (D)  $\left(\frac{180}{3x}\right)^\circ$

Item 58 refers to the following pair of similar triangles.

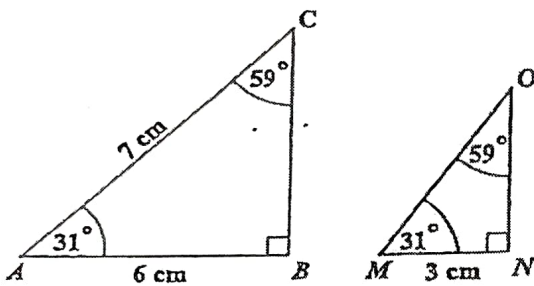

58. The length of  $MO$ , in centimetres, is

- (A) 3.0
- (B) 3.5
- (C) 6.0
- (D) 10.5

59.

A ship sailed 8 km due east from  $A$  to  $B$ . It then sailed 6 km due north to  $C$ . Which of the following diagrams BEST represents the path of the ship?

(A)

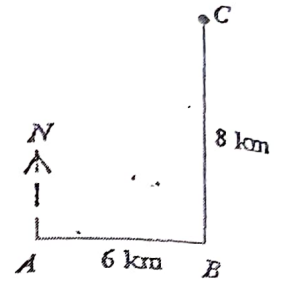

(B)

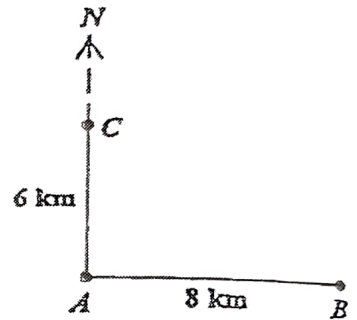

(C)

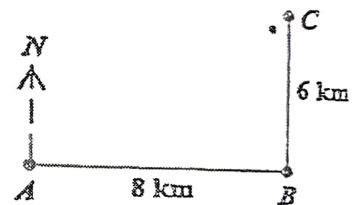

(D)

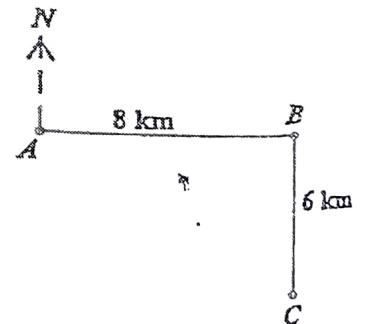

846

A005



60. Under the translation  $\begin{bmatrix} 2 \\ -3 \end{bmatrix}$ , the image of  $(3, -5)$  is
- (A)  $(0, -3)$
  - (B)  $(1, -2)$
  - (C)  $(5, -8)$
  - (D)  $(6, 15)$

END OF TEST

IF YOU FINISH BEFORE TIME IS CALLED, CHECK YOUR WORK ON THIS TEST.

01234010/JANUARY 2019





**CANDIDATE – PLEASE NOTE!**

PRINT your name on the line below and return this booklet with your answer sheet. Failure to do so may result in disqualification.

TEST CODE **01234010**

MAY/JUNE 2019

**FORM TP 2019089**

**CARIBBEAN EXAMINATIONS COUNCIL**

**CARIBBEAN SECONDARY EDUCATION CERTIFICATE®  
EXAMINATION**

**MATHEMATICS**

**Paper 01 – General Proficiency**

*1 hour 30 minutes*

**15 MAY 2019 (p.m.)**

**READ THE FOLLOWING INSTRUCTIONS CAREFULLY.**

1. This test consists of 60 items. You will have 1 hour and 30 minutes to answer them.
2. In addition to this booklet, you should have an answer sheet.
3. **A list of formulae is provided on page 2 of this booklet.**
4. Each item in this test has four suggested answers lettered (A), (B), (C), (D). Read each item you are about to answer and decide which choice is best.
5. On your answer sheet, find the number which corresponds to your item and shade the space having the same letter as the answer you have chosen. Look at the sample item below.

Sample Item

$2a + 6a =$

- (A)  $8a$
- (B)  $8a^2$
- (C)  $12a$
- (D)  $12a^2$

Sample Answer



The best answer to this item is “8a”, so (A) has been shaded.

6. If you want to change your answer, erase it completely before you fill in your new choice.
7. When you are told to begin, turn the page and work as quickly and as carefully as you can. If you cannot answer an item, go on to the next one. You may return to that item later.
8. You may do any rough work in this booklet.
9. Calculators and mathematical tables are NOT allowed for this paper.

**DO NOT TURN THIS PAGE UNTIL YOU ARE TOLD TO DO SO.**



**LIST OF FORMULAE**

Volume of a prism	$V = Ah$ where $A$ is the area of the cross-section and $h$ is the perpendicular length.
Volume of a cylinder	$V = \pi r^2 h$ where $r$ is the radius of the base and $h$ is the perpendicular height.
Volume of a right pyramid	$V = \frac{1}{3} Ah$ where $A$ is the area of the base and $h$ is the perpendicular height.
Circumference	$C = 2\pi r$ where $r$ is the radius of the circle.
Arc length	$S = \frac{\theta}{360} \times 2\pi r$ where $\theta$ is the angle subtended by the arc, measured in degrees.
Area of a circle	$A = \pi r^2$ where $r$ is the radius of the circle.
Area of a sector	$A = \frac{\theta}{360} \times \pi r^2$ where $\theta$ is the angle of the sector, measured in degrees.
Area of a trapezium	$A = \frac{1}{2} (a + b) h$ where $a$ and $b$ are the lengths of the parallel sides and $h$ is the perpendicular distance between the parallel sides.
Roots of quadratic equations	If $ax^2 + bx + c = 0$ ,

$$\text{then } x = \frac{-b \pm \sqrt{b^2 - 4ac}}{2a}$$

Trigonometric ratios	$\sin \theta = \frac{\text{length of opposite side}}{\text{length of hypotenuse}}$
	$\cos \theta = \frac{\text{length of adjacent side}}{\text{length of hypotenuse}}$
	$\tan \theta = \frac{\text{length of opposite side}}{\text{length of adjacent side}}$

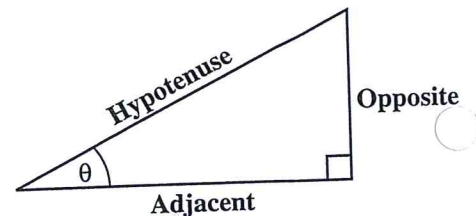

Area of a triangle  $\Delta = \frac{1}{2} bh$  where  $b$  is the length of the base and  $h$  is the perpendicular height.

$$\text{Area of } \Delta ABC = \frac{1}{2} ab \sin C$$

$$\text{Area of } \Delta ABC = \sqrt{s(s-a)(s-b)(s-c)}$$

$$\text{where } s = \frac{a+b+c}{2}$$

Sine rule  $\frac{a}{\sin A} = \frac{b}{\sin B} = \frac{c}{\sin C}$

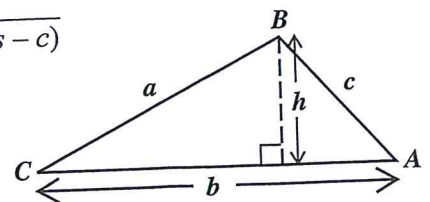

Cosine rule  $a^2 = b^2 + c^2 - 2bc \cos A$

1.  $(-3)^2 + (-2)^2$  is equal to

- (A) -13
- (B) -10
- (C) 13
- (D) 25

6. The square root of 181 lies between

- (A) 13 and 14
- (B) 45 and 46
- (C) 9 and 11
- (D) 11 and 13

2. What number when added to  $1\frac{1}{3}$  gives 2?

- (A)  $\frac{1}{3}$
- (B)  $\frac{2}{3}$
- (C) 1
- (D) 3

7. Which of the following sets is defined by  $\{x \in Z: -2 \leq x \leq 4\}$ ?

- (A)  $\{0, 1, 2, 3, 4\}$
- (B)  $\{1, 2, 3, 4\}$
- (C)  $\{-1, 0, 1, 2, 3\}$
- (D)  $\{-2, -1, 0, 1, 2, 3, 4\}$

3.  $11.1 \div 0.01$  is equal to

- (A) 110
- (B) 111
- (C) 1 100
- (D) 1 110

8. If  $Q = \{a, b, c\}$ , how many subsets can be obtained from the set  $Q$ ?

- (A)  $2 + 3$
- (B)  $2 \times 3$
- (C)  $3^2$
- (D)  $2^3$

4.  $12\frac{1}{2}\%$  of a sum of money is \$40.

What is the sum of money?

- (A) \$ 45
- (B) \$ 320
- (C) \$ 500
- (D) \$4 500

Item 9 refers to the following Venn diagram.

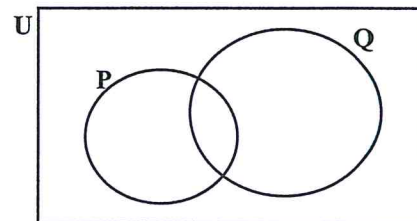

5. A test was marked out of 80. A boy scored 60% of the marks on the test. How many marks did he score?

- (A) 20
- (B) 48
- (C) 60
- (D) 75

9. In the Venn diagram,  $n(P) = 5$ ,  $n(Q) = 9$  and  $n(P \cup Q) = 10$ . What is  $n(P \cap Q)$ ?

- (A) 4
- (B) 6
- (C) 14
- (D) 24

Item 10 refers to the following information.

- $P = \{\text{prime numbers}\}$
- $Q = \{\text{odd numbers}\}$
- $R = \{\text{even numbers}\}$

10. Which of the following sets is empty?

- (A)  $P \cap R$
- (B)  $Q \cap R$
- (C)  $P \cap Q$
- (D)  $P \cup Q$

11. If  $P = \{2, 3, 5, 7\}$ ,  
 $Q = \{2, 3, 6\}$  and  
 $S = \{2, 4, 5\}$

then  $P \cap Q \cap S =$

- (A)  $\{2\}$
- (B)  $\{2, 3\}$
- (C)  $\{2, 3, 5\}$
- (D)  $\{2, 3, 4, 5, 6, 7\}$

Item 12 refers to the following Venn diagram.

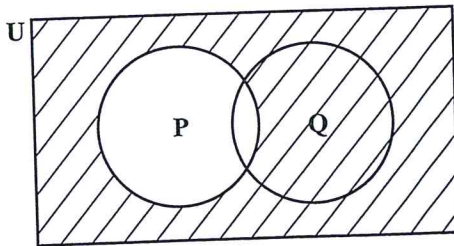

12. In the Venn diagram, the shaded area represents

- (A)  $P'$
- (B)  $(P \cup Q)'$
- (C)  $Q \cup P'$
- (D)  $Q \cap P'$

13. If TT\$6.00 is equivalent to US\$1.00, then TT\$15.00 in US dollars is

- (A) \$0.25
- (B) \$0.40
- (C) \$2.50
- (D) \$4.00

14. If \$7 000.00 is borrowed at the rate of 5% per annum for 3 years, the simple interest is

- (A) \$ 105
- (B) \$ 210
- (C) \$ 370
- (D) \$1 050

15. A dress which costs \$180.00 is being sold at a discount of 10%. The amount of the discount is

- (A) \$ 1.80
- (B) \$ 10.00
- (C) \$ 18.00
- (D) \$170.00

16. The value of a plot of land is \$18 000.00. Land tax is charged at the rate of \$0.70 per \$100.00 value. What is the TOTAL amount of tax paid for the land?

- (A) \$110.00
- (B) \$126.00
- (C) \$180.70
- (D) \$257.15

121

0057



17. At the end of any year a car is worth 5% less than what it was worth at the beginning of the year. If a car was worth \$9 500 in December 2016, then its value in January 2016 was
- (A) \$ 9 995  
(B) \$10 000  
(C) \$10 025  
(D) \$12 000
18. A loan of \$8 000 was repaid in 24 equal monthly instalments of \$400. The rate of interest on the loan was
- (A) 5%  
(B)  $8\frac{1}{3}\%$   
(C)  $16\frac{1}{3}\%$   
(D) 20%
19. A dinner at a restaurant was advertised at \$60.00 plus 18% tax. The total bill for this dinner was
- (A) \$60.00  
(B) \$70.80  
(C) \$78.00  
(D) \$81.60
20. At a sale, each book was marked \$3.00 off the original price. Daniel paid \$46.00 for two books that had the same sale price. What was the **original** cost of ONE of his books?
- (A) \$20.00  
(B) \$21.50  
(C) \$24.50  
(D) \$26.00
21.  $\frac{1}{5x} + \frac{2}{3x}$  is equal to
- (A)  $\frac{3}{8x^2}$   
(B)  $\frac{3}{8x}$   
(C)  $\frac{13}{15x^2}$   
(D)  $\frac{13}{15x}$
22. When 5 is added to a certain number and the result is multiplied by 3, the final answer is 27. What is the **original** number?
- (A) 4  
(B) 12  
(C) 14  
(D) 19
23. What is the value of  $\frac{x^2 + 3y}{xy}$ , if  $x = 4$  and  $y = 2$ ?
- (A)  $1\frac{3}{4}$   
(B)  $2\frac{1}{2}$   
(C)  $2\frac{3}{8}$   
(D)  $2\frac{3}{4}$
24. If  $x$  is an integer that satisfies the inequality  $4 < 2x \leq 6$ , then
- (A)  $2 < x \leq 3$   
(B)  $-2 < x \leq 3$   
(C)  $-3 < x \leq 2$   
(D)  $-3 \leq x < -2$



25. The sum of 2 positive numbers ( $p$  and  $q$ ) is 32. Their difference is 12. What is the SMALLER number?

- (A) 10
- (B) 12
- (C) 20
- (D) 22

26.  $3x^2 \times 2x^3 =$

- (A)  $6x$
- (B)  $6x^5$
- (C)  $6x^6$
- (D)  $72x^5$

27. Two matrices, A and B, are conformable for multiplication ( $A \times B$ ) if

- (A) the number of rows in A is equal to the number of columns in B
- (B) the number of columns in A is equal to the number of rows in B
- (C) both matrices are of the same order
- (D) both matrices are rectangular

28. The determinant of the identity matrix is

- (A) one
- (B) zero
- (C) undefined
- (D) negative one

29. If the vectors  $\mathbf{p}$  and  $\mathbf{q}$  are  $\begin{bmatrix} 3 \\ 2 \end{bmatrix}$  and  $\begin{bmatrix} -1 \\ 4 \end{bmatrix}$  respectively, then  $\mathbf{p} - 2\mathbf{q}$  is

(A)  $\begin{bmatrix} 1 \\ 10 \end{bmatrix}$

(B)  $\begin{bmatrix} 1 \\ -6 \end{bmatrix}$

(C)  $\begin{bmatrix} 5 \\ 10 \end{bmatrix}$

(D)  $\begin{bmatrix} 5 \\ -6 \end{bmatrix}$

Item 30 refers to the following parallelogram,  $WXYZ$ . In the parallelogram,  $\overrightarrow{XY} = \mathbf{u}$  and  $\overrightarrow{XW} = \mathbf{v}$ .  $R$  is the midpoint of  $YZ$ .

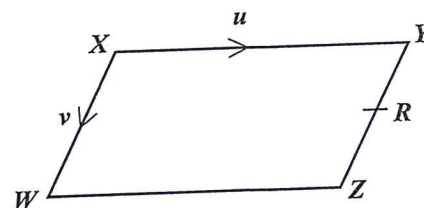

30.  $\overrightarrow{WR}$ , expressed in terms of  $\mathbf{u}$  and  $\mathbf{v}$ , is

(A)  $\mathbf{u} - \frac{1}{2} \mathbf{v}$

(B)  $\mathbf{u} + \frac{1}{2} \mathbf{v}$

(C)  $-\mathbf{u} + \frac{1}{2} \mathbf{v}$

(D)  $-\frac{1}{2} \mathbf{v} - \mathbf{u}$

31. Given that 1 millimetre =  $\frac{1}{1000}$  metres,

2 500 millimetres in metres is

- (A) 0.25
- (B) 2.5
- (C) 25
- (D) 250

Item 32 refers to the following diagram which shows a sector of a circle,  $AOB$ , such that  $AOB = 60^\circ$  and  $OB$  is  $r$  units long.

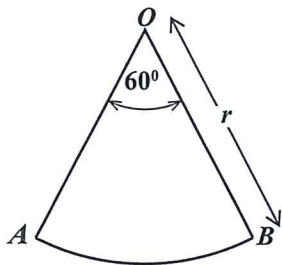

32. The area of  $AOB$  is

- (A)  $\frac{1}{6} \pi r^2$
- (B)  $\frac{1}{6} \pi r$
- (C)  $\frac{1}{3} \pi r^2$
- (D)  $\frac{1}{3} \pi r$

33. The volume, in  $\text{cm}^3$ , of a cube of edge 3 cm is

- (A) 9
- (B) 18
- (C) 27
- (D) 54

34. The perimeter of a square is 48 cm. What is the area, in  $\text{cm}^2$ ?

- (A) 36
- (B) 72
- (C) 108
- (D) 144

35. Which of the following figures, **not drawn to scale**, has an area equal to  $\frac{1}{2}(5 + 4) \times 2$  square units?

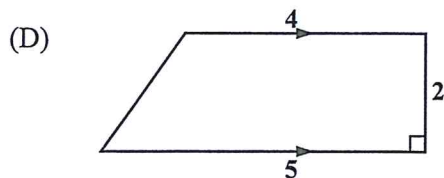
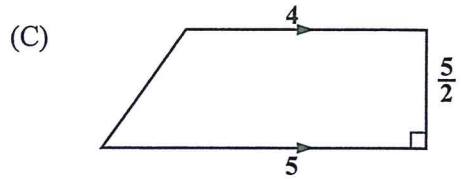
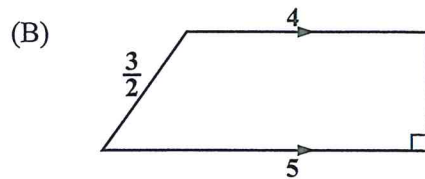
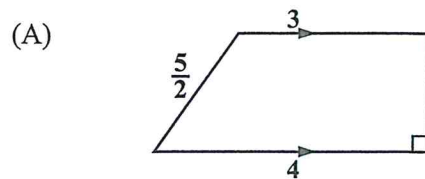

36. The area of a rectangle is  $53.6 \text{ cm}^2$ . If the length is multiplied by four and the width is halved, the area would then be

- (A)  $26.8 \text{ cm}^2$
- (B)  $53.6 \text{ cm}^2$
- (C)  $107.2 \text{ cm}^2$
- (D)  $214.4 \text{ cm}^2$

Item 37 refers to the following diagram which shows a sector of a circle, with centre  $O$ .

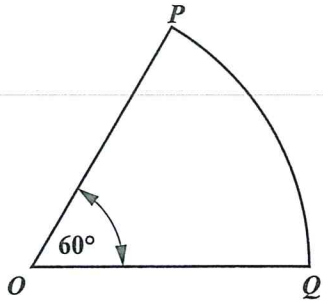

37. If the length of the minor arc  $PQ$  is 8 cm, what is the length of the circumference of the circle?
- (A) 16 cm  
(B) 24 cm  
(C) 48 cm  
(D) 64 cm
38. The area of a triangle is  $30 \text{ cm}^2$  and its base is 10 cm. What is the height, in cm, of the triangle?
- (A) 6  
(B) 12  
(C) 13  
(D) 17

Item 39 refers to the following histogram which shows the number of children aged 4, 5, 6, 7 and 8 who took part in a survey.

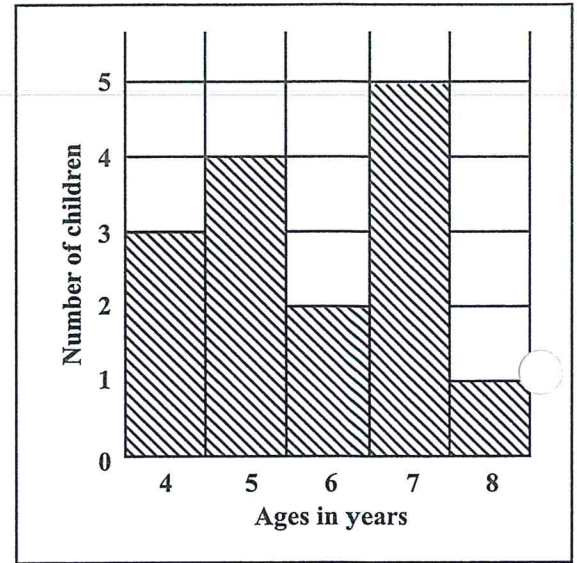

39. What was the modal age?
- (A) 5  
(B) 6  
(C) 7  
(D) 8

Items 40–42 refer to the following diagram which shows the cumulative frequency curve based on the marks of 200 students who took a driving test.

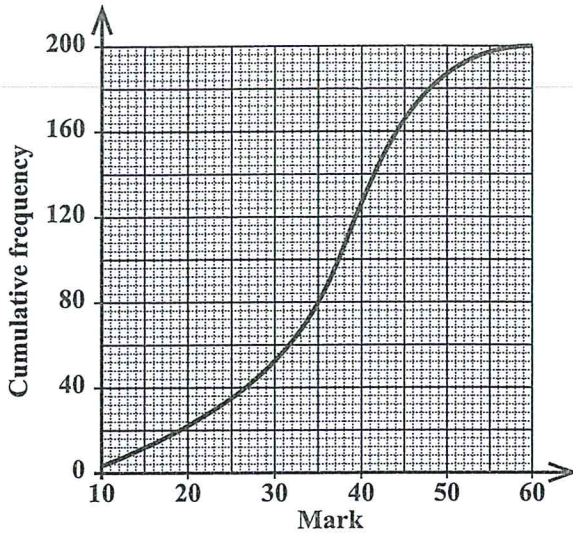

40. The median mark scored by the 200 students is
- (A) 30.0  
 (B) 37.5  
 (C) 40.0  
 (D) 100.0
41. What is the interquartile range of the marks scored by the 200 students?
- (A) 12.5  
 (B) 30.0  
 (C) 42.5  
 (D) 100.0

42. If 38% of the students passed the test, what was the pass mark?
- (A) 20  
 (B) 40  
 (C) 76  
 (D) 124

43. The following table shows the frequency of scores obtained by students in a test.

Scores	2	3	5	6	8	10
No. of Students	8	4	6	3	9	2

The range of the scores is

- (A) 2  
 (B) 7  
 (C) 8  
 (D) 10

Item 44 refers to the following two-way table, which shows the mode of transportation to school on a particular day, for a group of 200 students.

	Bus	Taxi	Walk	Total
Male	30	50	28	108
Female	44	16	32	92
Total	74	66	60	200

44. A male student is picked at random from the group. What is the probability that he does NOT walk to school on that day?
- (A)  $\frac{2}{5}$   
 (B)  $\frac{13}{18}$   
 (C)  $\frac{20}{27}$   
 (D)  $\frac{7}{10}$



45. Which of the following represents the graph of a function?

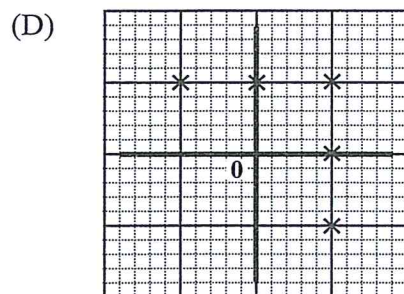
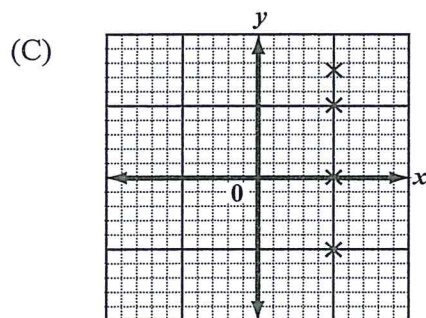
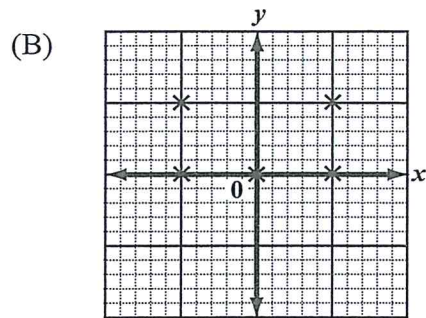
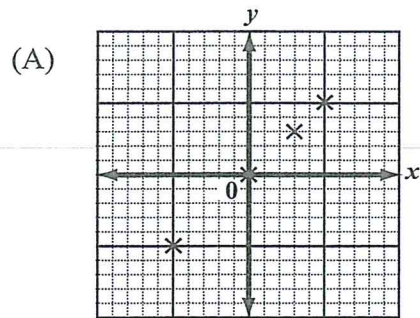

46. If  $f(x) = 2x^2 - 1$ , then  $f(-3) =$

- (A) -32
- (B) -19
- (C) 17
- (D) 35

Item 47 refers to the following graph of a straight line.

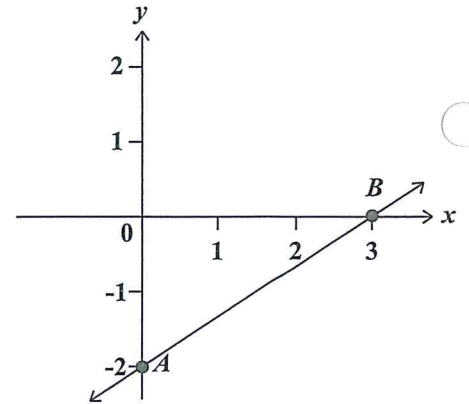

47. The straight line  $AB$  cuts the  $y$  axis at

- (A)  $(0, 3)$
- (B)  $(0, 2)$
- (C)  $(3, -2)$
- (D)  $(0, -2)$

48. The equation of the line which passes through the point  $(0, 5)$  and has a gradient of 4 is

- (A)  $y = 4x$
- (B)  $y = 5x$
- (C)  $y = 4x + 5$
- (D)  $y = 5x + 4$

49. The range of  $f: x \rightarrow x^3$  for the domain  $\{-2, -1, 0, 1, 2\}$  is

- (A)  $\{8, 1, 0, 1, 8\}$   
 (B)  $\{6, 3, 0, 3, 6\}$   
 (C)  $\{-6, -3, 0, 3, 6\}$   
 (D)  $\{-8, -1, 0, 1, 8\}$

Items 50–51 refer to the following graph of a function.

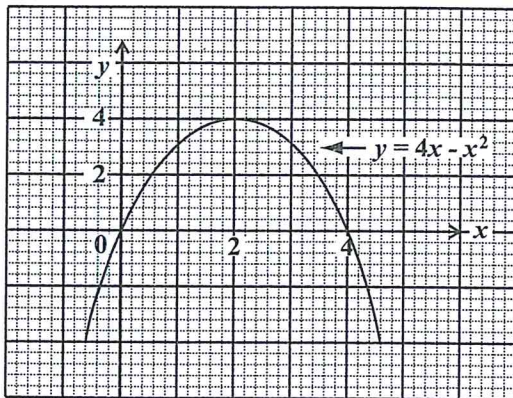

50. The values of  $x$  for which  $y = 4x - x^2$  intersects  $y = 0$  are

- (A)  $x = 0$  and  $x = 4$   
 (B)  $x = 0$  and  $x = 2$   
 (C)  $x = 0$  and  $x = -4$   
 (D)  $x = 2$  and  $x = 4$

51. The coordinates of the turning point of  $y = 4x - x^2$  are

- (A)  $(0, 0)$   
 (B)  $(0, 4)$   
 (C)  $(4, 2)$   
 (D)  $(2, 4)$

52. Which of the following pairs of lines is perpendicular?

- (A)  $2y = -3x - 8$   
 $3x - 2y = -8$   
 (B)  $y = 2x + 1$   
 $y = 2x - 6$   
 (C)  $y = -4x + 10$   
 $4y = x + 1$   
 (D)  $x - 2y = -1$   
 $3x + 5y = 8$

Item 53 refers to the following diagram of a transformation.

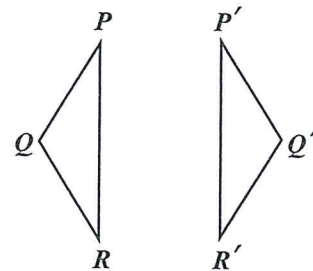

53. What transformation maps  $PQR$  onto  $P'Q'R'$ ?

- (A) Enlargement  
 (B) Rotation  
 (C) Translation  
 (D) Reflection



Item 58 refers to the following diagram.

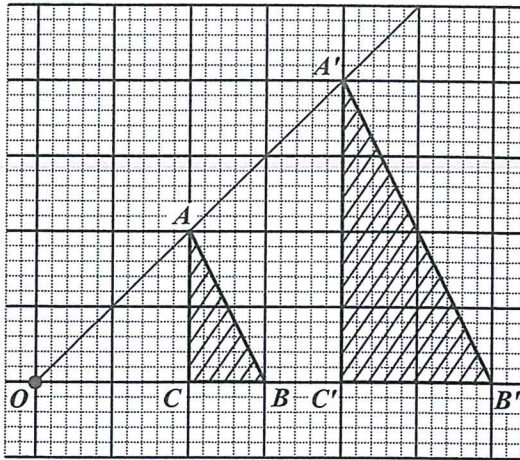

58.  $OAA'$ ,  $OBB'$  and  $OCC'$  are straight lines.  $\triangle ABC$  is mapped onto  $\triangle A'B'C'$  by an enlargement with centre  $O$ . What is the scale factor of the enlargement?

- (A)  $\frac{1}{2}$   
 (B)  $-\frac{1}{2}$   
 (C) 2  
 (D) -2

59. A plane is flying in a direction of  $045^\circ$  and changes course in a clockwise direction to  $135^\circ$ . The angle through which the plane turns is

- (A)  $45^\circ$   
 (B)  $90^\circ$   
 (C)  $135^\circ$   
 (D)  $270^\circ$

Item 60 refers to the following diagram, **not drawn to scale**, which shows that the angle of depression of a point  $X$  from  $Z$  is  $30^\circ$ .

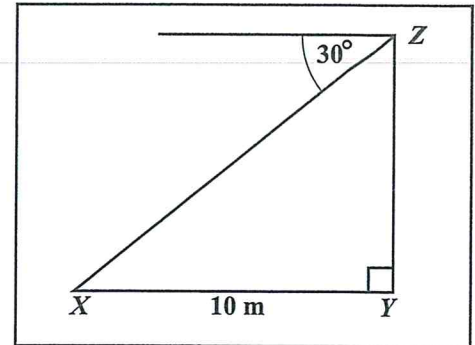

60. If  $X$  is 10 metres from  $Y$ , the height of  $YZ$ , in metres, is

- (A)  $10 \tan 30^\circ$   
 (B)  $10 \sin 30^\circ$   
 (C)  $10 \cos 30^\circ$   
 (D)  $10 \cos 60^\circ$

END OF TEST

IF YOU FINISH BEFORE TIME IS CALLED, CHECK YOUR WORK ON THIS TEST.





**CANDIDATE – PLEASE NOTE!**

PRINT your name on the line below and return this booklet with your answer sheet. Failure to do so may result in disqualification.

TEST CODE **01234010**

MAY/JUNE 2020

**FORM TP 2020091**

**CARIBBEAN EXAMINATIONS COUNCIL  
CARIBBEAN SECONDARY EDUCATION CERTIFICATE®  
EXAMINATION**

**MATHEMATICS**

**Paper 01 – General Proficiency**

*1 hour 30 minutes*

**13 MAY 2020 (p.m.)**

**READ THE FOLLOWING INSTRUCTIONS CAREFULLY.**

1. This test consists of 60 items. You will have 1 hour and 30 minutes to answer them.
2. In addition to this booklet, you should have an answer sheet.
3. **A list of formulae is provided on page 2 of this booklet.**
4. Each item in this test has four suggested answers lettered (A), (B), (C), (D). Read each item you are about to answer and decide which choice is best.
5. On your answer sheet, find the number which corresponds to your item and shade the space having the same letter as the answer you have chosen. Look at the sample item below.

Sample Item

$$2a + 6a =$$

- (A)  $8a$
- (B)  $8a^2$
- (C)  $12a$
- (D)  $12a^2$

Sample Answer

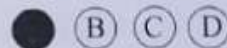

The best answer to this item is “ $8a$ ”, so (A) has been shaded.

6. If you want to change your answer, erase it completely before you fill in your new choice.
7. When you are told to begin, turn the page and work as quickly and as carefully as you can. If you cannot answer an item, go on to the next one. You may return to that item later.
8. You may do any rough work in this booklet.
9. Calculators and mathematical tables are NOT allowed for this paper.

**DO NOT TURN THIS PAGE UNTIL YOU ARE TOLD TO DO SO.**

Copyright © 2018 Caribbean Examinations Council  
All rights reserved.

01234010/MJ/CSEC 2020

1.  $(-3)^2 + (-2)^2$  is equal to

- (A) -13
- (B) -10
- (C) 5
- (D) 13

2. What is the value of the digit 2 in the number 48.621?

- (A)  $\frac{2}{100}$
- (B)  $\frac{2}{10}$
- (C) 2
- (D) 200

3. Using the distributive property

$$49 \times 17 + 49 \times 3 =$$

- (A)  $49 \times 20$
- (B)  $49 + 20$
- (C)  $52 \times 66$
- (D)  $52 + 66$

4. A total of 540 beads are shared in the ratio 4:5. The LARGER share of beads is

- (A) 60
- (B) 240
- (C) 300
- (D) 432

5. 0.45 written as a common fraction, in its simplest form, is

- (A)  $\frac{9}{20}$
- (B)  $\frac{4}{5}$
- (C)  $\frac{9}{10}$
- (D)  $\frac{5}{4}$

6. Dan sold 40 concert tickets in 5 days. Each day he sold 3 tickets MORE than the previous day. The number of tickets he sold on the third day is

- |     |    |            |                           |     |     |           |
|-----|----|------------|---------------------------|-----|-----|-----------|
| (A) | 8  | M          | T                         | W   | T   | F         |
| (B) | 9  | x          | x+3                       | x+6 | x+9 | x+12 = 40 |
| (C) | 10 | $5x+30=40$ |                           |     |     |           |
| (D) | 11 | x=2        | <u><math>2+6=8</math></u> |     |     |           |

Item 7 refers to the following Venn diagram which shows the number of members of a sports club who play rugby or basketball.

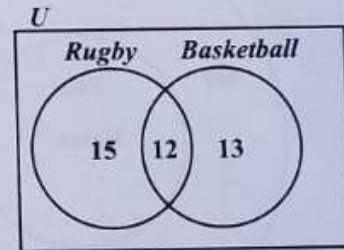

7. The number of members who play rugby but NOT basketball is

- (A) 12
- (B) 15
- (C) 28
- (D) 40

GO ON TO THE NEXT PAGE

Item 8 refers to the following Venn diagram.

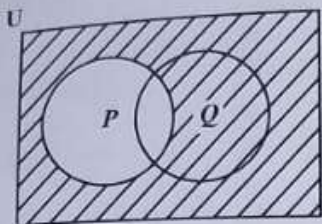

8. The shaded region represents

- (A)  $P'$
- (B)  $(P \cup Q)'$
- (C)  $P \cup Q'$
- (D)  $Q \cap P'$

Items 9–10 refer to the following Venn diagram which shows the universal set ( $U$ ), and two sets,  $T$  and  $C$ , that represent the students in a class who play tennis ( $T$ ) and chess ( $C$ ).

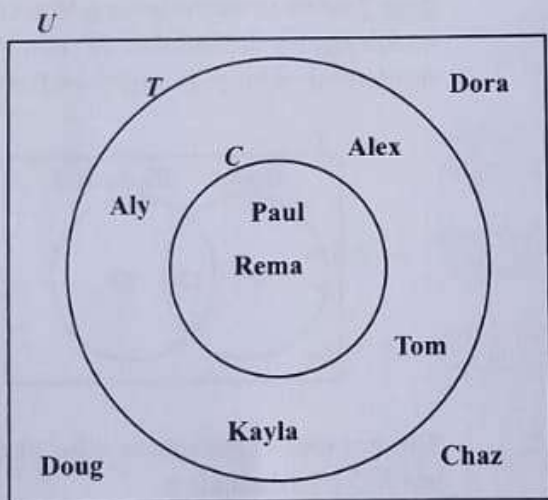

9. How many students play BOTH games?

- (A) 2
- (B) 3
- (C) 4
- (D) 6

10. How many students play EXACTLY one game?

- (A) 2
- (B) 3
- (C) 4
- (D) 6

Item 11 refers to the following information on the description of 3 sets.

- $P = \{\text{prime numbers}\}$
- $Q = \{\text{odd numbers}\}$
- $R = \{\text{even numbers}\}$

11. Which of the following sets is empty?

- (A)  $P \cap R$
- (B)  $P \cup Q$
- (C)  $P \cap Q$
- (D)  $Q \cap R$

12. If  $n(A) = 14$ ,  $n(B) = 15$ , and  $n(A \cap B) = 6$ , then  $n(A \cup B)$  is

- (A) 2
- (B) 19
- (C) 23
- (D) 29

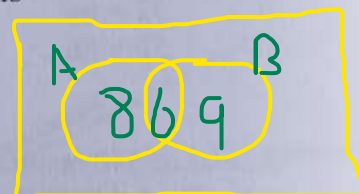

$8+6+9=23$

13. A dress which costs \$180 is being sold at a discount of 10%. The amount of the discount is

- (A) \$ 1.80
- (B) \$ 10.00
- (C) \$ 18.00
- (D) \$170.00

14. A dinner at a restaurant was advertised at \$60 plus 18% tax. The total bill for this dinner was
- (A) \$60.00
  - (B) \$70.80**
  - (C) \$78.00
  - (D) \$81.60
15. The cost price of a refrigerator is \$1 850.00. A buyer who is given a discount of 5% for a cash purchase will pay
- (A) \$1 942.50
  - (B) \$1 845.00
  - (C) \$1 757.50**
  - (D) \$ 1350.00
16. The annual interest rate on a mortgage on a house assessed at a value of \$450 000 is 5 cents on every \$1. What is the interest paid on the mortgage for the first year?
- (A) \$ 11 750
  - (B) \$ 22 500**
  - (C) \$107 500
  - (D) \$117 500
17. The simple interest on a sum of money invested at 5% per annum for 3 years was \$90.
- The sum of money invested was
- (A) \$ 54
  - (B) \$ 150
  - (C) \$ 600**
  - (D) \$1350
18. At the end of any year a car is worth 5% less than what it was worth at the beginning of the year. If a car is worth \$9 500 in December 2016, then its value in January 2016 was
- (A) \$ 9 025
  - (B) \$ 9 995
  - (C) \$10 000**
  - (D) \$10 025
19. A television set costs \$350 cash. When bought on hire purchase, a deposit of \$35 is required, followed by 12 monthly payments of \$30 each. How much is saved by paying cash?
- (A) \$10
  - (B) \$25
  - (C) \$40
  - (D) \$45**
20. A man's regular pay is \$3 per hour up to 40 hours. Overtime is twice the payment for regular time. If he was paid \$216, how many hours of overtime did he work?
- (A) 8
  - (B) 16**
  - (C) 28
  - (D) 48
21.  $3x - 4(x + 6) =$
- (A)  $-x + 6$
  - (B)  $-x - 24$**
  - (C)  $-7x + 6$
  - (D)  $-7x - 24$

GO ON TO THE NEXT PAGE

22. If  $5(2x - 1) = 35$ , then  $x =$
- (A)  $-4$
  - (B)  $\frac{1}{4}$
  - (C)  $3$
  - (D)  $4$
23. If  $x$  is an integer that satisfies the inequality  $4 < 2x \leq 6$ , then
- (A)  $2 < x \leq 3$
  - (B)  $2 < x \leq 6$
  - (C)  $4 < x \leq 3$
  - (D)  $4 < x \leq 6$
24. Given that  $3 * 6 = 12$  and  $2 * 5 = 9$ , then  $a * b$  may be defined as
- (A)  $4(b - a)$
  - (B)  $a^2 - b$
  - (C)  $6a - b$
  - (D)  $2a + b$
25. If  $p + q = -1$  and  $pq = -6$ , then  $p^3 + q^3 =$
- (A)  $-19$
  - (B)  $-13$
  - (C)  $25$
  - (D)  $35$

26. The distance  $L$  that an elastic string is stretched by hanging an object of mass  $m$  varies directly as the mass of that object. If a 5-kg object stretches the string 31 cm, how far will a 29-kg object stretch the string?
- (A) 4.68 cm
  - (B) 6.2 cm
  - (C) 135.72 cm
  - (D) 179.8 cm

27. Given that  $A = \begin{bmatrix} 1 & 3 & -3 \\ 3 & 0 & 5 \end{bmatrix}$ , then  $3A$  equals

(A)  $\begin{bmatrix} 3 & 9 & -9 \\ 9 & 0 & 15 \end{bmatrix}$

(B)  $\begin{bmatrix} 4 & 6 & -6 \\ 6 & 3 & 8 \end{bmatrix}$

(C)  $\begin{bmatrix} 3 & 9 & -6 \\ 9 & 0 & 15 \end{bmatrix}$

(D)  $\begin{bmatrix} -2 & 0 & 6 \\ 0 & 3 & 2 \end{bmatrix}$

Item 28 refers to the following matrix,  $P$ .

$$P = \begin{bmatrix} 8 & 6 \\ 7 & 5 \end{bmatrix}$$

28. The determinant of  $P$ ,  $|P|$ , is
- (A) 2
  - (B)  $-2$
  - (C)  $-13$
  - (D) 26

Item 29 refers to the following vectors,  $\mathbf{p}$  and  $\mathbf{q}$ .

$$\mathbf{p} = \begin{pmatrix} 3 \\ 7 \end{pmatrix} \quad \mathbf{q} = \begin{pmatrix} -2 \\ 5 \end{pmatrix}$$

29. The vector  $\mathbf{p} - \mathbf{q}$  is represented by

(A)  $\begin{pmatrix} 1 \\ 12 \end{pmatrix}$

(B)  $\begin{pmatrix} 5 \\ 12 \end{pmatrix}$

(C)  $\begin{pmatrix} 5 \\ 2 \end{pmatrix}$

(D)  $\begin{pmatrix} 1 \\ 5 \end{pmatrix}$

Item 30 refers to the following diagram of triangle  $PQR$ , in which  $L$  is the midpoint of  $PR$  and  $\vec{QP} = \mathbf{a}$  and  $\vec{QR} = \mathbf{b}$ .

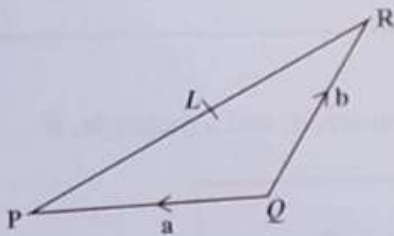

30.  $\vec{PL}$  expressed in terms of  $\mathbf{a}$  and  $\mathbf{b}$  is

(A)  $\frac{\mathbf{a} + \mathbf{b}}{2}$

(B)  $\frac{\mathbf{b} - \mathbf{a}}{2}$

(C)  $\frac{-\mathbf{b} - \mathbf{a}}{2}$

(D)  $\frac{\mathbf{a} - \mathbf{b}}{2}$

31. The length 3 800 millimetres expressed in metres is

(A) 0.38

(B) 3.8

(C) 38

(D) 380

32. The volume of a cube with edge 10 cm is

(A)  $30 \text{ cm}^3$

(B)  $100 \text{ cm}^3$

(C)  $300 \text{ cm}^3$

(D)  $1\,000 \text{ cm}^3$

33. The distance around the edge of a circular pond is 88 metres. The radius, in metres, is

(A)  $88\pi$

(B)  $176\pi$

(C)  $\frac{88}{\pi}$

(D)  $\frac{88}{2\pi}$

Item 34 refers to the following diagram, not drawn to scale, which shows a cylinder of radius 3 cm and height 8 cm.

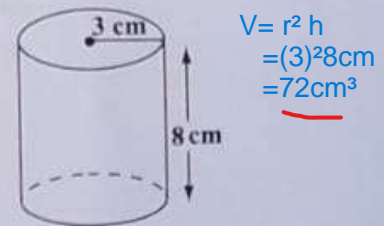

34. The volume of the cylinder is

(A)  $12 \pi \text{ cm}^3$

(B)  $48 \pi \text{ cm}^3$

(C)  $72 \pi \text{ cm}^3$

(D)  $192 \pi \text{ cm}^3$

GO ON TO THE NEXT PAGE

Item 35 refers to the following diagram, not drawn to scale, which shows a sector of a circle with centre  $O$ .

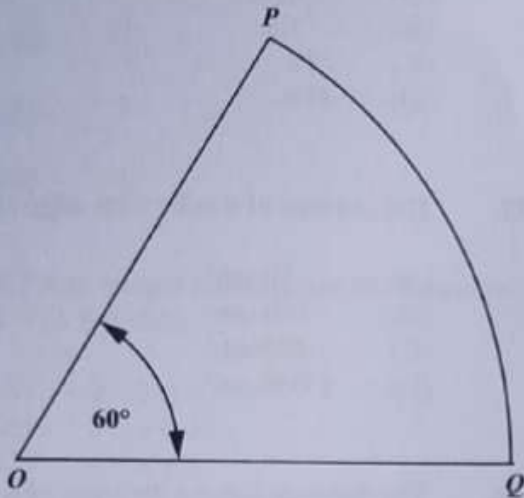

35. If the length of the minor arc  $PQ$  is 8 cm, what is the circumference of the circle?

- (A) 16 cm
- (B) 24 cm
- (C) 48 cm
- (D) 64 cm

36. A man leaves home at 22:15 hours and reaches his destination at 04:00 hours on the following day in the same time zone. How many hours did the journey take?

- (A) 5
- (B)  $5\frac{3}{4}$
- (C) 6
- (D)  $6\frac{1}{4}$

---

Item 37 refers to the following diagram which shows a square,  $A$ , and a rectangle,  $B$ .

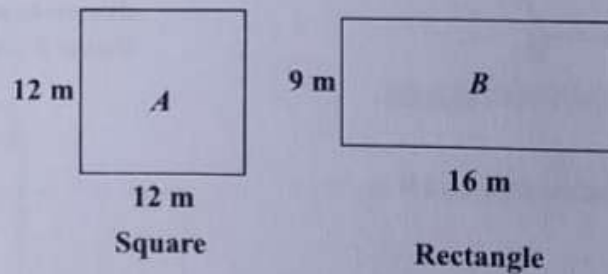

37. Which of the following statements is true about the perimeters of the figures  $A$  and  $B$ ?

- (A) Perimeter of  $A$  = perimeter of  $B$
- (B) Perimeter of  $A$  < perimeter of  $B$
- (C) Perimeter of  $A$   $\geq$  perimeter of  $B$
- (D) Perimeter of  $A$  > perimeter of  $B$

Item 38 refers to the following diagram, not drawn to scale, which consists of a triangle resting on a square of side 5 cm.

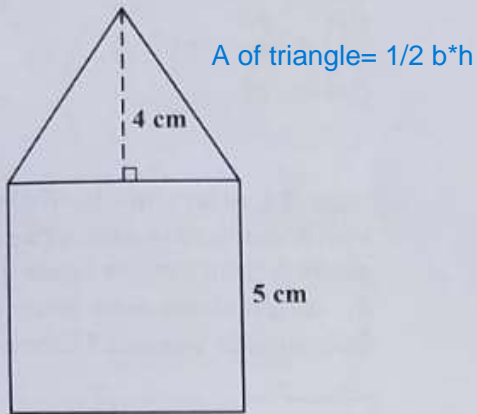

38. If the height of the triangle is 4 cm, what is the TOTAL area of the figure?

- (A) 35 cm<sup>2</sup>
- (B) 45 cm<sup>2</sup>
- (C) 50 cm<sup>2</sup>
- (D) 100 cm<sup>2</sup>

Items 39–40 refer to the following histogram which shows the number of children aged 4, 5, 6, 7 and 8 who took part in a survey.

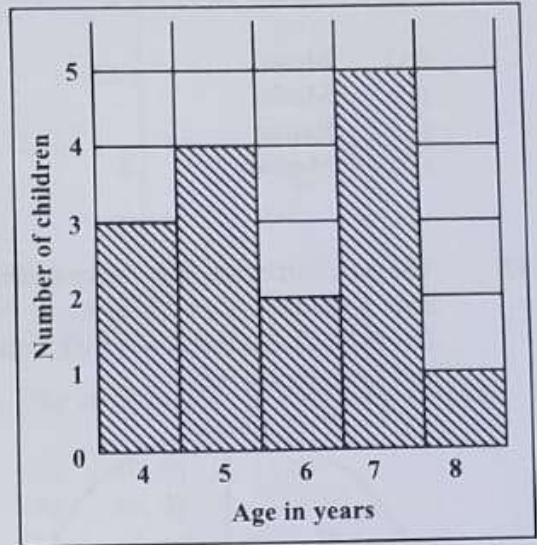

39. What was the modal age?

- (A) 5
- (B) 6
- (C) 7
- (D) 8

40. How many children took part in the survey?

- (A) 5
- (B) 15
- (C) 75
- (D) 87

GO ON TO THE NEXT PAGE

41. Ms Clarke arranged the 15 test scores of her students in order of size and selected the 8th score for reporting purposes. Which of the following statistical measures did Ms Clarke obtain?

- (A) Mean
- (B) Mode
- (C) Range
- (D) Median

42. The pie chart below, **drawn to scale**, shows how a student used 12 hours in studying English (*E*), Mathematics (*M*), French (*F*) and Geography (*G*).

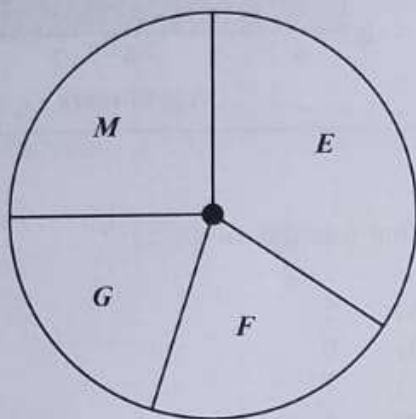

The amount of time spent studying Mathematics is APPROXIMATELY

- (A) 1 hour
- (B) 2 hours
- (C) 3 hours
- (D) 4 hours

43. If the mean of the 4 numbers 4, 8,  $x$  and 12 is 10, then  $x$  is

- (A) 4
- (B) 10
- (C) 12
- (D) 16

Item 44 refers to the following table which shows the results of a survey of 100 persons, from 2 major ethnic groups, *P* and *R*. Respondents were interviewed about their attitude towards Mathematics.

Attitude Towards Mathematics	Ethnicity		Total
	<i>P</i>	<i>R</i>	
Positive	25	12	37
Neutral	11	9	20
Negative	24	19	43
Total	60	40	100

44. A respondent is selected at random. What is the probability that he has a positive attitude towards Mathematics?

- (A) 0.20
- (B) 0.37
- (C) 0.43
- (D) 0.60

GO ON TO THE NEXT PAGE

45. Which of the following diagrams BEST illustrates a function?

- (A)
- (B)
- (C)
- (D)

Item 46 refers to the following graph of a straight line.

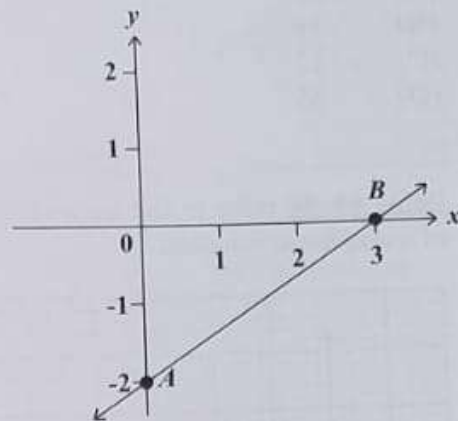

46. The straight line  $AB$  cuts the  $y$ -axis at

- (A)  $(0, 3)$
- (B)  $(0, 2)$
- (C)  $(3, -2)$
- (D)  $(0, -2)$

Item 47 refers to the following graph of a straight line.

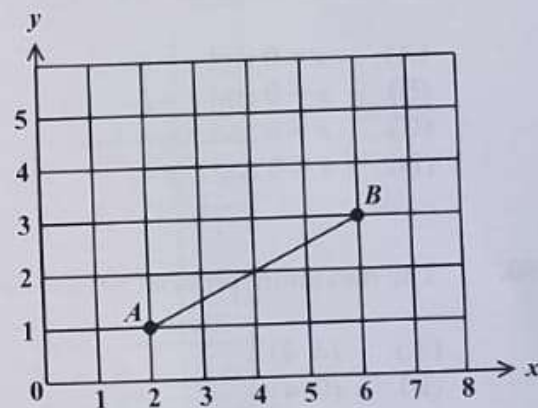

47. The gradient of  $AB$  in the graph above is

- (A)  $-\frac{1}{2}$
- (B)  $\frac{1}{2}$
- (C)  $-2$
- (D)  $2$

GO ON TO THE NEXT PAGE

48. If  $f(x) = 2x^2 - 1$ , then  $f(-3) =$

- (A) -32
- (B) -19
- (C) 17
- (D) 35

Items 49–50 refer to the following graph of a quadratic function.

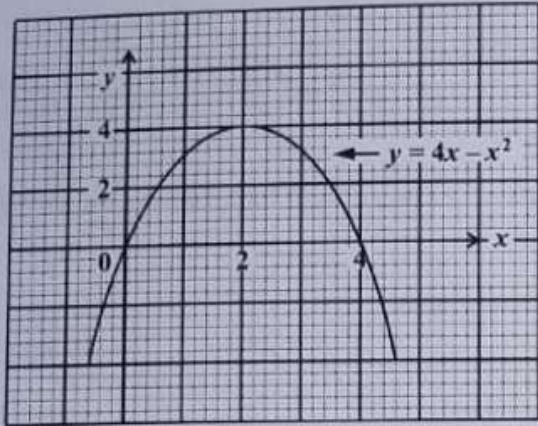

49. The values of  $x$  at the points where the curve  $y = 4x - x^2$  intersects the line  $y = 0$  are

- (A)  $x = 0$  and  $x = 4$
- (B)  $x = 0$  and  $x = 2$
- (C)  $x = 0$  and  $x = -4$
- (D)  $x = 2$  and  $x = 4$

50. The maximum point of  $y = 4x - x^2$  is

- (A) (4, 4)
- (B) (0, 4)
- (C) (4, 2)
- (D) (2, 4)

51. A parking lot charges \$1.00 plus \$0.25 for every hour ( $h$ ) or part thereof in which a vehicle is parked. A function,  $C(h)$ , that represents the parking cost is

- (A)  $C(h) = 0.25h$
- (B)  $C(h) = 1.00h + 0.25$
- (C)  $C(h) = 0.25h + 1.00$
- (D)  $C(h) = \frac{h}{0.25} + 1.00$

Item 52 refers to the following arrow diagram which shows a function,  $f$ .

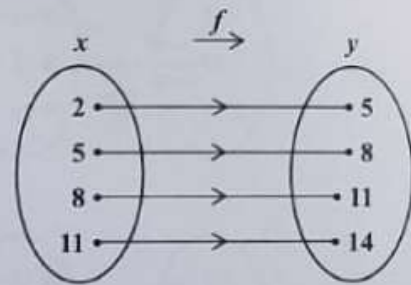

52. Which of the following BEST describes the function?

- (A)  $y = x + 3$
- (B)  $x + y = 3$
- (C)  $x = y + 3$
- (D)  $y = 2x + 1$

53. If the sum of the interior angles of a polygon is 4 right angles, then the polygon is a

- (A) triangle
- (B) hexagon
- (C) pentagon
- (D) quadrilateral

54. C

55. C

56. B

GO ON TO THE NEXT PAGE

Item 57 refers to the following diagram which shows a transformation.

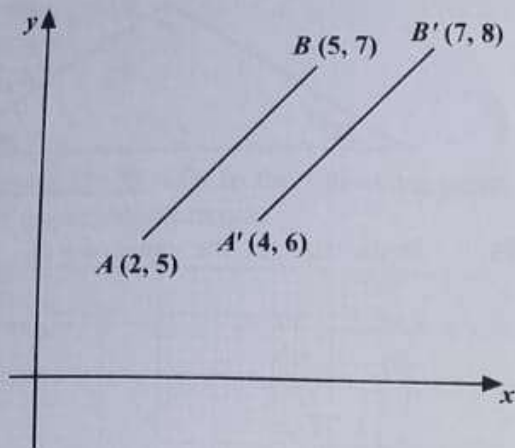

57. In the diagram, the translation by which  $AB$  is mapped onto  $A'B'$  is represented by

(A)  $\begin{pmatrix} 1 \\ 1 \end{pmatrix}$

(B)  $\begin{pmatrix} 2 \\ 1 \end{pmatrix}$

(C)  $\begin{pmatrix} 3 \\ 2 \end{pmatrix}$

(D)  $\begin{pmatrix} 5 \\ 3 \end{pmatrix}$

Item 58 refers to the following diagram which shows a transformation.

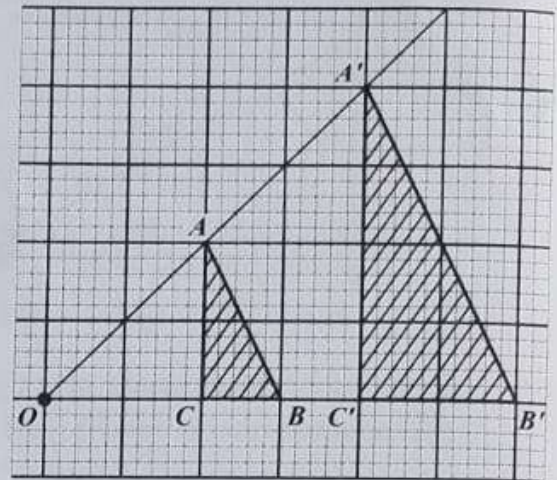

58.  $OAA'$ ,  $OBB'$  and  $OCC'$  are straight lines.  $\triangle ABC$  is mapped onto  $\triangle A'B'C'$  by an enlargement with centre  $O$ . What is the scale factor of the enlargement?

(A)  $-2$

(B)  $-\frac{1}{2}$

(C)  $\frac{1}{2}$

(D)  $2$

Item 59 refers to the following pair of similar triangles.

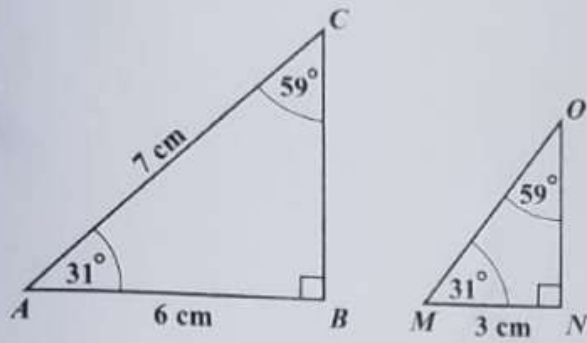

59. The length of  $MO$ , in centimetres, is

- (A) 2.5
- (B) 3.0
- (C) 3.5
- (D) 7.0

Item 60 refers to the following diagram.

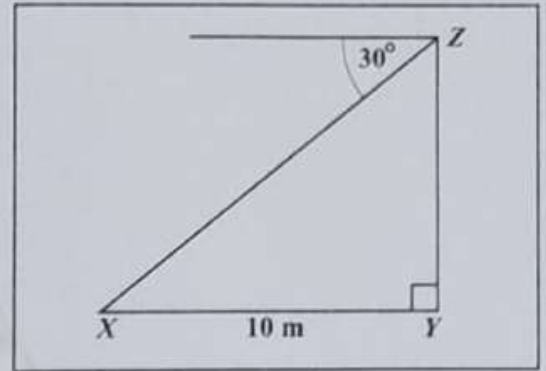

60. The diagram above, **not drawn to scale**, shows that the angle of depression of a point  $X$  from  $Z$  is  $30^\circ$ . If  $X$  is 10 metres from  $Y$ , the height of  $YZ$ , in metres, is

- (A)  $10 \tan 30^\circ$
- (B)  $10 \sin 30^\circ$
- (C)  $10 \cos 30^\circ$
- (D)  $10 \cos 60^\circ$

END OF TEST

IF YOU FINISH BEFORE TIME IS CALLED, CHECK YOUR WORK ON THIS TEST.



**CANDIDATE – PLEASE NOTE!**

PRINT your name on the line below and return this booklet with your answer sheet. Failure to do so may result in disqualification.

**FORM TP 2021018**

TEST CODE **01234010**

JANUARY 2021

**CARIBBEAN EXAMINATIONS COUNCIL  
CARIBBEAN SECONDARY EDUCATION CERTIFICATE®  
EXAMINATION**

**MATHEMATICS**

**Paper 01 – General Proficiency**

*1 hour 30 minutes*

**05 JANUARY 2021 (p.m.)**

**READ THE FOLLOWING INSTRUCTIONS CAREFULLY.**

1. This test consists of 60 items. You will have 1 hour and 30 minutes to answer them.
2. In addition to this test booklet, you should have an answer sheet.
3. **A list of formulae is provided on page 2 of this booklet.**
4. Each item in this test has four suggested answers lettered (A), (B), (C), (D). Read each item you are about to answer and decide which choice is best.
5. On your answer sheet, find the number which corresponds to your item and shade the space having the same letter as the answer you have chosen. Look at the sample item below.

Sample Item

$2a + 6a =$

- (A)  $8a$
- (B)  $8a^2$
- (C)  $12a$
- (D)  $12a^2$

Sample Answer

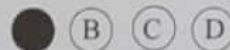

The best answer to this item is “ $8a$ ”, so (A) has been shaded.

6. If you want to change your answer erase it completely before you fill in your new choice.
7. When you are told to begin, turn the page and work as quickly and as carefully as you can. If you cannot answer an item, go on to the next one. You may return to that item later.
8. You may do any rough work in this booklet.
9. Calculators and mathematical tables are NOT allowed for this paper.
10. **ALL diagrams in this booklet are NOT drawn to scale, unless otherwise stated.**

**DO NOT TURN THIS PAGE UNTIL YOU ARE TOLD TO DO SO.**

Copyright © 2020 Caribbean Examinations Council  
All rights reserved.

01234010/J/CSEC 2021

1. What is the value of the digit 2 in the number 48.621?

- (A)  $\frac{2}{100}$
- (B)  $\frac{2}{10}$
- (C) 2
- (D) 200

2.  $22.2 \div 0.02 =$

- (A) 110
- (B) 111
- (C) 1 100
- (D) 1 110

3. In standard notation, 208.06 is written as

- (A)  $2.0806 \times 10^2$
- (B)  $20.806 \times 10^1$
- (C)  $2.0806 \times 10^{-2}$
- (D)  $0.20806 \times 10^3$

4. In a school the ratio of the number of pupils to the number of teachers is 20:1. If the number of pupils is 840, how many teachers are there?

- (A) 40
- (B) 42
- (C) 820
- (D) 840

5. What is the LEAST number of apples that can be shared equally among either 6, 10 or 15 children?

- (A) 24
- (B) 30
- (C) 60
- (D) 90

6. If  $4.3 \times 0.37 = 1.591$ , then  $0.43 \times 370$  is

- (A) 1.591
- (B) 15.91
- (C) 159.1
- (D) 1591.0

7. If  $P = \{2, 3, 5, 7\}$ ,  
 $Q = \{2, 3, 6\}$  and  
 $S = \{2, 4, 5\}$ ,

then  $P \cap (Q \cup S) =$

- (A) {2}
- (B) {2, 3}
- (C) {2, 3, 5}
- (D) {2, 3, 4, 5, 6, 7}

GO ON TO THE NEXT PAGE

Item 8 refers to the following Venn diagram.

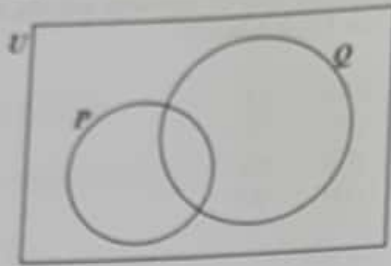

In the Venn diagram,  $n(P) = 5$ ,  $n(Q) = 9$  and  $n(P \cup Q) = 10$ .

8. What is  $n(Q \cap P)$ ?

- (A) 1
- (B) 4
- (C) 5
- (D) 9

9. Which of the following pairs of sets is an example of disjoint sets?

- (A)  $E = \{\text{even numbers}\}$  and  $F = \{\text{odd numbers}\}$
- (B)  $P = \{\text{multiples of 2}\}$  and  $Q = \{\text{multiples of 3}\}$
- (C)  $X = \{\text{whole numbers}\}$  and  $Y = \{\text{rational numbers}\}$
- (D)  $G = \{\text{multiples of five}\}$  and  $H = \{\text{multiples of ten}\}$

10. All students in a class play Scrabble or Checkers or both. If 36% of the students play Scrabble only and 48% of the students play Checkers only, what percentage of students play BOTH games?

- (A) 12
- (B) 16
- (C) 84
- (D) 88

Item 11 refers to the following Venn diagram which shows 2 intersecting sets.

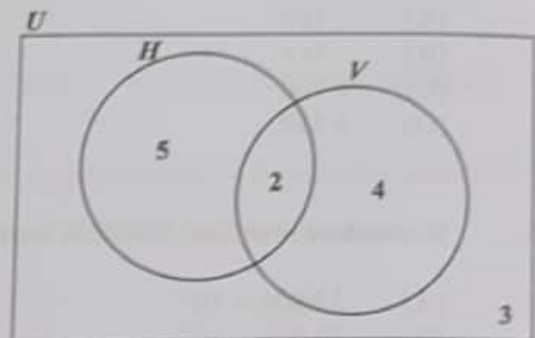

11. In the Venn diagram

- $U = \{\text{students who play games}\}$
- $H = \{\text{students who play hockey}\}$
- $V = \{\text{students who play volleyball}\}$

The number of students in each set is indicated. How many students play EXACTLY one game?

- (A) 6
- (B) 7
- (C) 9
- (D) 11

Item 12 refers to the following Venn diagram of 2 intersecting sets which is partially shaded.

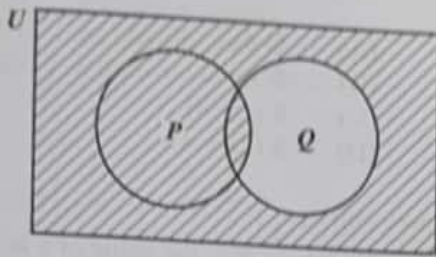

12. In the Venn diagram, the unshaded area represents
- (A)  $P'$
  - (B)  $Q'$
  - (C)  $P \cap Q'$
  - (D)  $Q \cap P'$
13. For every \$100 sales, a salesman is paid \$10.00 as commission. If his sales for a particular month were \$1 020.00, how much commission was he paid?
- (A) \$ 10.20
  - (B) \$ 20.20
  - (C) \$102.00
  - (D) \$110.00
14. At a store, sales tax is charged at a rate of 2% on the cost price of an item. The sales tax on a dress which costs \$180 is
- (A) \$ 3.60
  - (B) \$ 10.80
  - (C) \$176.40
  - (D) \$183.60
15. If EC \$2.50 is equivalent to US \$1.00, then EC \$25.00, in US dollars, is
- (A) \$ 5.00
  - (B) \$10.00
  - (C) \$62.50
  - (D) \$80.00
16. A calculator which is marked at \$120 is sold for cash at a 30% discount. How much change would Susan receive if she pays for the calculator with a \$100 bill?
- (A) \$16
  - (B) \$20
  - (C) \$28
  - (D) \$36
17. A loan of \$8 000 was paid back in 2 years in monthly payments of \$400. The interest on the loan, as a percentage, was
- (A) 5%
  - (B)  $8\frac{1}{3}\%$
  - (C)  $16\frac{2}{3}\%$
  - (D) 20%
18. A car presently valued at \$12 000 depreciates at the rate of 10% per annum. What will be the value of the car one year later?
- (A) \$10 800
  - (B) \$11 800
  - (C) \$11 880
  - (D) \$13 200
19. A man pays 60 cents for every 200 m<sup>3</sup> of gas used, plus a fixed charge of \$13.75. How much does he pay when he uses 55 000 m<sup>3</sup> of gas?
- (A) \$151.25
  - (B) \$165.00
  - (C) \$175.25
  - (D) \$178.75



20. If \$7 000 is borrowed at the rate of 5% per annum for 3 years, the simple interest is

- (A) \$ 105
- (B) \$ 210
- (C) \$ 350
- (D) \$1 050

21. The product of a number  $p$  and its reciprocal may be written as

- (A)  $p^2 \times \frac{1}{p}$
- (B)  $p^2 \times -p$
- (C)  $p \times \frac{1}{p}$
- (D)  $p \times -p$

Item 22 refers to the following diagram of a rectangle.

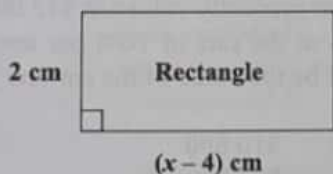

22. The area of the rectangle, in  $\text{cm}^2$ , is  $x^2$ . The equation that may be used to find the value of  $x$  is

- (A)  $x^2 = 2(x - 4)$
- (B)  $x^2 = (x - 2)(x - 4)$
- (C)  $x^2 = (x - 4)(x + 2)$
- (D)  $x^2 = 2(x - 4)(x - 2)$

23. Althea normally saves \$ $x$  each month; but in June she saved \$4 more than twice her usual amount. In June she saved

- (A) \$  $4x$
- (B) \$  $6x$
- (C) \$  $(x + 4)$
- (D) \$  $(2x + 4)$

24. If  $3 + \frac{2}{x} = 1$ , the value of  $x$  is

- (A) -1
- (B)  $\frac{1}{5}$
- (C)  $\frac{1}{2}$
- (D) 5

25.  $5^{n+1} \times 5^{n+2}$  is the same as

- (A)  $5^{2n}$
- (B)  $5^{2n+3}$
- (C)  $5^{3(2n)}$
- (D)  $2 \times 5^{2n}$

26. If  $5(y - 2) - 3(y + 4) = 0$ , then  $y$  is

- (A) -1
- (B) 3
- (C) 7
- (D) 11



27. If  $|A| = 0$ , then  $A$  is
- (A) an inverse matrix
  - (B) a singular matrix
  - (C) an identity matrix
  - (D) a non-singular matrix

28. If  $A = \begin{pmatrix} 1 & 2 & 5 & 4 \\ 6 & 1 & 3 & 7 \\ -2 & 3 & 2 & 9 \end{pmatrix}$ , then the order of  $A$  is

- (A)  $2 \times 3$
- (B)  $3 \times 2$
- (C)  $3 \times 4$
- (D)  $4 \times 3$

29. If the vectors  $\mathbf{p}$  and  $\mathbf{q}$  are  $\begin{pmatrix} 3 \\ 2 \end{pmatrix}$  and  $\begin{pmatrix} -1 \\ 4 \end{pmatrix}$  respectively, then  $-\mathbf{p} - 2\mathbf{q}$  is

- (A)  $\begin{pmatrix} 5 \\ -6 \end{pmatrix}$
- (B)  $\begin{pmatrix} -2 \\ -6 \end{pmatrix}$
- (C)  $\begin{pmatrix} 5 \\ 10 \end{pmatrix}$
- (D)  $\begin{pmatrix} -1 \\ -10 \end{pmatrix}$

Item 30 refers to the following diagram of triangle  $OLM$ , in which  $R$  is the midpoint of  $OL$  and  $T$  the midpoint of  $OM$ . Further,  $\vec{OR} = \mathbf{a}$  and  $\vec{OT} = \mathbf{b}$ .

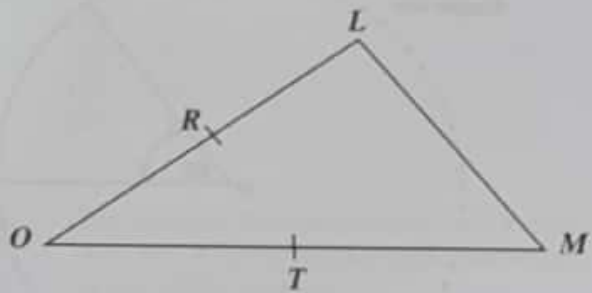

30.  $\vec{LM}$  expressed in terms of  $\mathbf{a}$  and  $\mathbf{b}$  is

- (A)  $\mathbf{b} - \mathbf{a}$
- (B)  $\mathbf{a} + \mathbf{b}$
- (C)  $2(\mathbf{a} + \mathbf{b})$
- (D)  $2(\mathbf{b} - \mathbf{a})$

31. If it took a speedboat 9 hours to travel a distance of 1 080 km, what was its average speed, in  $\text{kmh}^{-1}$ ?

- (A) 12
- (B) 102
- (C) 120
- (D) 1200



Item 32 refers to the following diagram which shows a circle, centred at  $O$ , and with a sector and the major and minor arcs indicated.

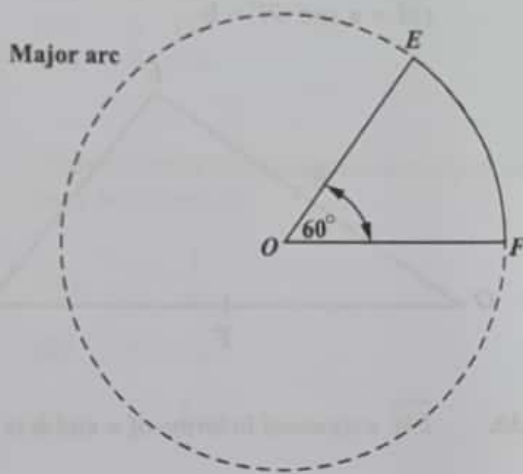

32. In the diagram, the length of the corresponding major arc,  $FE$ , is 40 cm. What is the circumference of the circle, in cm?

- (A) 24
- (B) 48
- (C) 50
- (D) 64

Item 33 refers to the following diagram which shows a cylinder with diameter 6 cm and height  $h$  cm.

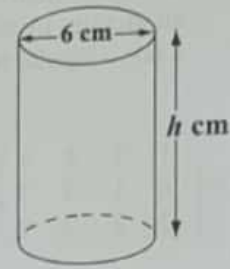

33. If the volume of the cylinder, in terms of  $\pi$ , is  $180\pi \text{ cm}^3$ , then the height of the cylinder, in cm, is

- (A) 9
- (B) 20
- (C) 30
- (D) 36

34. The lengths of the sides of a triangle are  $x$ ,  $2x$  and  $2x$  centimetres. If the perimeter is 20 centimetres, what is the value of  $x$ ?

- (A) 4
- (B) 5
- (C) 8
- (D) 10

GO ON TO THE NEXT PAGE



35. Fifty guests had 2 glasses of champagne each. Each glass held 150 millilitres. How many litres of champagne were used?

- (A) 0.15
- (B) 1.5
- (C) 15
- (D) 150

36. A square has the same area as a rectangle with sides of length 9 centimetres and 16 centimetres. What is the length of the side of the square?

- (A) 9 cm
- (B) 12 cm
- (C) 12.5 cm
- (D) 75 cm

37. The circumference of a circle is 154 cm.

Given that  $\pi = \frac{22}{7}$ , the diameter of the circle, in centimetres, is

- (A) 7
- (B) 24.5
- (C) 49
- (D) 54

38. The area of a triangle is  $60 \text{ cm}^2$  and its base is 12 cm. What is the perpendicular height, in cm, of the triangle?

- (A) 5
- (B) 10
- (C) 13
- (D) 17

---

Item 39 refers to the following table which shows the number of books 58 students bought at a sale.

No. of Books Bought	3	4	5	6	7	8
No. of Students	9	9	13	11	9	7

39. The mode of the number of books bought is

- (A) 5
- (B) 7
- (C) 9
- (D) 13

Item 43 refers to the following diagram which shows the cumulative frequency curve of the heights of 20 plants.

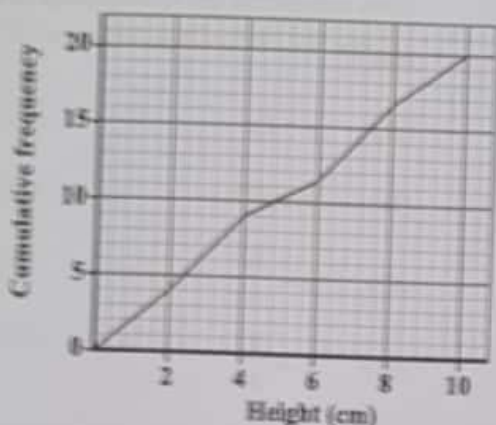

43. The interquartile range of the set of measurements is

- (A) 2.4 cm
- (B) 5.0 cm
- (C) 7.4 cm
- (D) 10.0 cm

Item 44 refers to the following table which shows the results of a survey of 100 persons from 2 major ethnic groups, P and R. Respondents were interviewed about their attitude towards Mathematics.

Attitude Towards Mathematics	Ethnicity		Total
	P	R	
Positive	25	12	37
Neutral	11	9	20
Negative	24	19	43
Total	60	40	100

44. A respondent from ethnic Group P is selected at random. What is the probability that he has a negative attitude towards Mathematics?

- (A)  $\frac{11}{100}$
- (B)  $\frac{6}{25}$
- (C)  $\frac{1}{4}$
- (D)  $\frac{2}{5}$

Item 45 refers to the following arrow diagram.

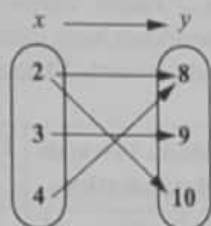

45. The arrow diagram above describes the relation

- (A)  $y$  is less than  $x$
- (B)  $y$  is a factor of  $x$
- (C)  $x$  is a factor of  $y$
- (D)  $x$  is a multiple of  $y$

46. The set of ordered pairs below represents a relation that is a function.

$$\{(-2, 7), (4, 6), (10, 4)\}$$

Which of the following points, when added to the set, would form a relation that is NOT a function?

- (A)  $(1, 3)$
- (B)  $(0, 4)$
- (C)  $(-2, 8)$
- (D)  $(-8, 10)$

47. If  $h(x) = \frac{3x-2}{5}$ , then  $h(-6) =$

- (A)  $-4$
- (B)  $-\frac{16}{5}$
- (C)  $\frac{16}{5}$
- (D)  $4$

48. Given that  $y$  varies inversely as  $x$ , and  $y = 16$  when  $x = \frac{1}{2}$ , which of the following equations represents the relationship between  $x$  and  $y$ ?

- (A)  $y = 8x$
- (B)  $y = 32x$
- (C)  $y = \frac{32}{x}$
- (D)  $y = \frac{8}{x}$

49. Which of the following represents the equation of a straight line?

- (A)  $xy = 4$
- (B)  $y + 4 = x^2$
- (C)  $y + 3 = 2x$
- (D)  $y = x^2 + 2x - 5$

50. What is the  $x$ -value of the point of intersection for the system represented by the functions

$$f(x) = 3 \text{ and } g(x) = \frac{5}{2}x + 1?$$

- (A)  $0.8$
- (B)  $1.6$
- (C)  $5.0$
- (D)  $8.5$

GO ON TO THE NEXT PAGE



51. A line  $L$  is parallel to the line

$$2x - 5y - 8 = 0.$$

What is the gradient of the line  $L$ ?

- (A)  $-\frac{5}{2}$
- (B)  $-\frac{2}{5}$
- (C)  $\frac{2}{5}$
- (D)  $2$

52. Which of the following sets is represented by the function  $f: x \rightarrow x^2 + 3$  where  $x \in \{0, 1, 2, 3\}$ ?

- (A)  $\{(0, 3), (1, 1), (2, 4), (3, 9)\}$
- (B)  $\{(0, 3), (1, 4), (2, 5), (3, 6)\}$
- (C)  $\{(0, 3), (1, 5), (2, 7), (3, 9)\}$
- (D)  $\{(0, 3), (1, 4), (2, 7), (3, 12)\}$

Item 53 refers to the following diagram of a circle.

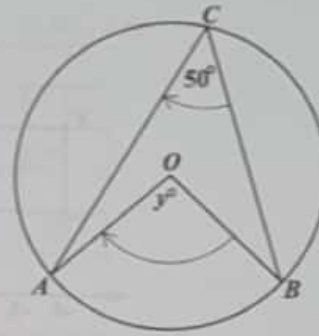

53. If  $O$  is the centre of the circle, then  $y^\circ$  is

- (A)  $25^\circ$
- (B)  $80^\circ$
- (C)  $90^\circ$
- (D)  $100^\circ$

Item 54 refers to the following diagram.

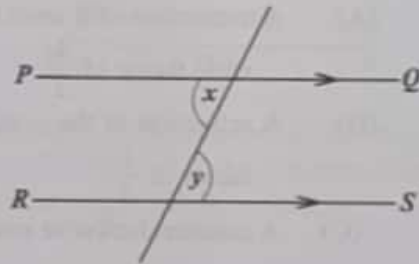

54. In the diagram  $PQ$  and  $RS$  are parallel. Which of the following BEST describes the relation between  $x$  and  $y$ ?

- (A)  $x = y$
- (B)  $x < y$
- (C)  $x + y = 90^\circ$
- (D)  $x + y = 180^\circ$

GO ON TO THE NEXT PAGE

Item 55 refers to the following diagram which shows rectangle  $WXYZ$  and its image  $W'X'Y'Z'$  and  $W''X''Y''Z''$  after it undergoes a composite/double transformation.

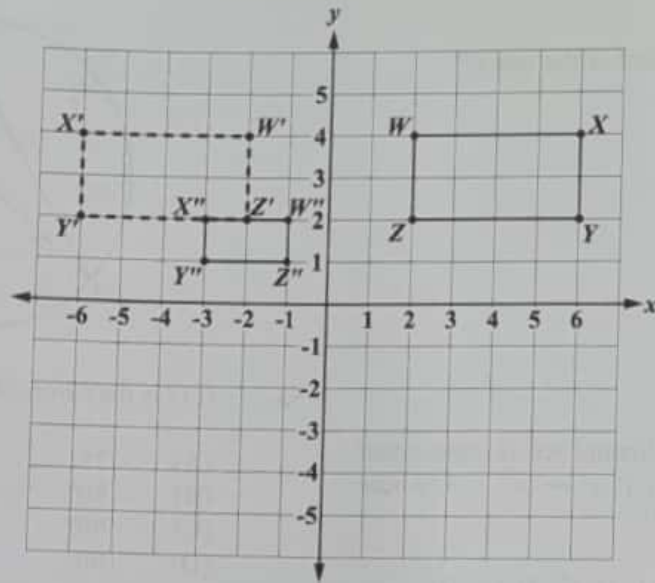

55. What sequence of transformations will map rectangle  $WXYZ$  onto its image, rectangle  $W''X''Y''Z''$ ?
- (A) A translation of 8 units to the left, followed by an enlargement, centred at the origin with scale factor of  $\frac{1}{2}$
  - (B) A reflection in the  $y$ -axis, followed by an enlargement, centred at the origin with scale factor of  $\frac{1}{2}$
  - (C) A counterclockwise rotation of  $90^\circ$  about the origin, followed by an enlargement, centred at the origin with scale factor of  $\frac{1}{2}$
  - (D) An enlargement, centred at the origin with scale factor of  $\frac{1}{2}$ , followed by a counterclockwise rotation of  $90^\circ$  about the origin



56. In each of the following diagrams,  $A'$  is the image of  $A$ . Which of the diagrams shows a reflection in the  $x$ -axis?

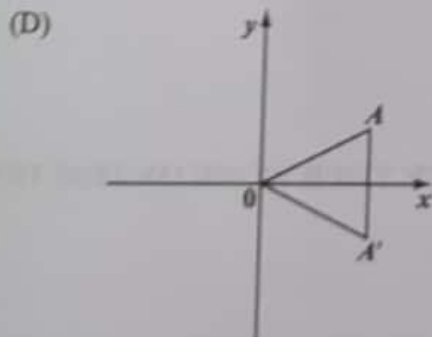
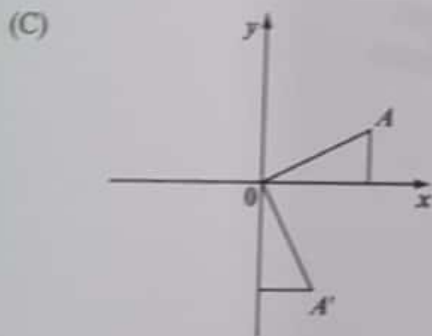
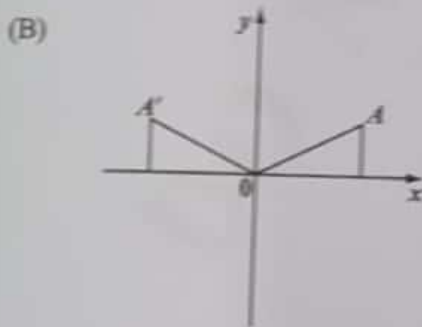
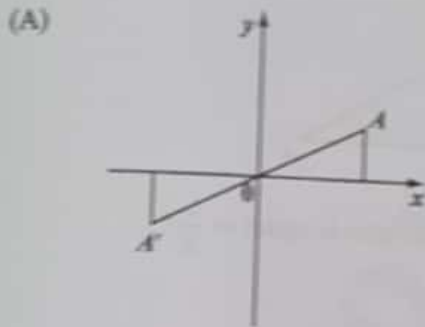

57. In triangle  $ABC$ , angle  $A = x^\circ$  and angle  $B = 2x^\circ$ . What is the size of angle  $C$ ?

- (A)  $(180 - 3x)^\circ$
- (B)  $60^\circ$
- (C)  $30^\circ$
- (D)  $\left[\frac{180}{3x}\right]^\circ$

Item 58 refers to the following diagram which shows the angle of depression of a point,  $X$ , from  $Z$ .

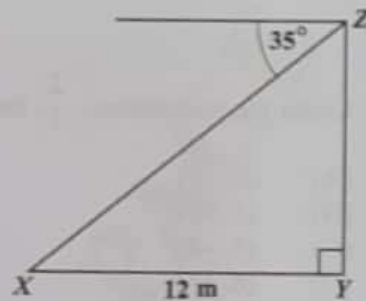

58. The angle of depression of the point  $X$  from  $Z$  is  $35^\circ$ . If  $X$  is 12 metres from  $Y$ , then the height  $YZ$ , in metres, is

- (A)  $12 \cos 35^\circ$
- (B)  $12 \tan 35^\circ$
- (C)  $12 \sin 35^\circ$
- (D)  $12 \cos 55^\circ$

GO ON TO THE NEXT PAGE

Item 40 refers to the following pie chart which shows the popular games played by 720 students.

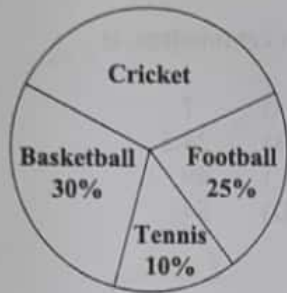

40. How many students play cricket?

- (A) 35
- (B) 120
- (C) 252
- (D) 300

Items 41–42 refer to the following chart which shows the amount of fish bought, in kg, by the first 60 customers at a fish market.

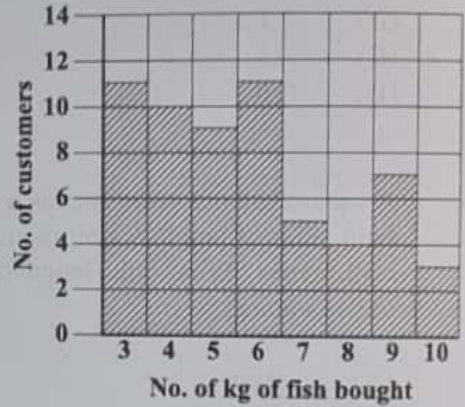

41. How many customers bought at LEAST 6 kg of fish?

- (A) 18
- (B) 19
- (C) 34
- (D) 30

42. The median amount of fish bought by customers is

- (A) 5.5 kg
- (B) 6 kg
- (C) 6.5 kg
- (D) 30 kg



1.  $(-3)^2 + (-2)^2$  is equal to
- (A) -13  
(B) -10  
(C) 13  
(D) 25
2. What percentage of 40 is 8?
- (A) 5%  
(B) 20%  
(C) 32%  
(D) 150%
3. If  $235 \times 48.7 = 11\,444.5$ , then
- $$23.5 \times 0.487 =$$
- (A) 11.4445  
(B) 114.445  
(C) 1\,144.45  
(D) 11\,444.4
4. Using the distributive property,
- $$49 \times 17 + 49 \times 3 =$$
- (A)  $49 \times 20$   
(B)  $49 + 20$   
(C)  $52 \times 66$   
(D)  $52 + 66$
5. A test was marked out of 80. A boy scored 60% of the marks on the test. How many marks did he score?
- (A) 20  
(B) 48  
(C) 60  
(D) 75
6. Dan sold 40 concert tickets in 5 days. Each day he sold 3 tickets MORE than the previous day. The number of tickets he sold on the third day is
- (A) 8  
(B) 9  
(C) 10  
(D) 11
7. Which of the following sets is defined by  $\{x \in \mathbb{Z} : -2 \leq x \leq 4\}$ ?
- (A)  $\{1, 2, 3, 4\}$   
(B)  $\{0, 1, 2, 3, 4\}$   
(C)  $\{-1, 0, 1, 2, 3\}$   
(D)  $\{-2, -1, 0, 1, 2, 3, 4\}$
8. If  $Q = \{a, b, c\}$ , how many subsets can be obtained from the set  $Q$ ?
- (A)  $2 + 3$   
(B)  $2 \times 3$   
(C)  $3^2$   
(D)  $2^3$
9. The set of positive integers is an example of
- (A) a finite set  
(B) an empty set  
(C) an infinite set  
(D) an improper set
10. If  $n(U) = 25$ ,  $n(A) = 14$ ,  $n(B) = 15$  and  $n(A \cap B) = 6$ , then  $n(A \cup B)$  is
- (A) 2  
(B) 19  
(C) 23  
(D) 29

Item 11 refers to the following Venn diagram.

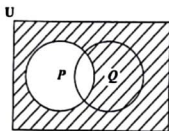

11. The shaded region represents

- (A)  $P'$
- (B)  $(P \cup Q)'$
- (C)  $P \cup Q'$
- (D)  $Q \cap P'$

12. The 30 students in Teacher May's class have either a dog or a cat or none of the two. Sixteen students have a dog ( $D$ ), 12 students have a cat ( $C$ ) and the remainder have neither a cat nor a dog. Which of the Venn diagrams below correctly represents this information?

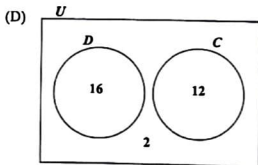
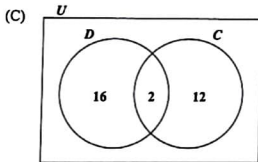
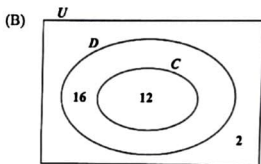
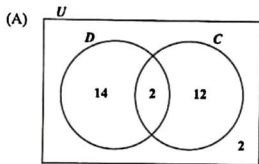

GO ON TO THE NEXT PAGE

13. At a bank, EC\$2.60 is equivalent to US\$1.00. For every US\$1.00 exchanged, EC\$0.10 is deducted as an exchange fee. How much EC dollars will Leon receive if he exchanges US\$100.00?
- (A) \$ 90.90  
(B) \$ 236.34  
(C) \$ 250.00  
(D) \$ 260.00
14. If \$7 000 is borrowed at the rate of 5% per annum for 3 years, the simple interest is
- (A) \$ 105  
(B) \$ 210  
(C) \$ 370  
(D) \$1 050
15. A dress which costs \$180.00 is being sold at a discount of 10%. The amount of the discount is
- (A) \$ 1.80  
(B) \$ 10.00  
(C) \$ 18.00  
(D) \$170.00
16. An article bought for \$125 was sold for \$175. The profit as a percentage of the cost price was
- (A) 28.6  
(B) 40  
(C) 50  
(D) 71.4
17. The value of a plot of land is \$18 000. Land tax is charged at the rate of \$0.70 per \$100 value. What is the TOTAL amount of tax paid for the land?
- (A) \$100.70  
(B) \$110.00  
(C) \$126.00  
(D) \$180.70
18. If the simple interest on \$900 for 3 years was \$108, what was the rate of interest?
- (A) 4%  
(B) 8%  
(C) 12%  
(D) 25%
19. At the end of any year a car is worth 5% less than what it was worth at the beginning of the year. If a car is worth \$9 500 in December 2016, then its value in January 2016 was
- (A) \$ 9 995  
(B) \$10 000  
(C) \$10 025  
(D) \$12 000
20. A man's regular pay is \$3 per hour up to 40 hours. Overtime is twice the payment for regular time. If he was paid \$216, how many hours of overtime did he work?
- (A) 8  
(B) 16  
(C) 28  
(D) 48

21.  $\frac{1}{5x} + \frac{2}{3x}$  is equal to
- (A)  $\frac{3}{8x^2}$   
(B)  $\frac{3}{8x}$   
(C)  $\frac{13}{15x^2}$   
(D)  $\frac{13}{15x}$
22. Seven times the product of two numbers,  $a$  and  $b$ , may be written as
- (A)  $7ab$   
(B)  $49ab$   
(C)  $7a + b$   
(D)  $7(a + b)$
23. What is the value of  $\frac{x^2 + 3y}{xy}$ , if  $x = 4$  and  $y = 2$ ?
- (A)  $1\frac{3}{4}$   
(B)  $2\frac{1}{2}$   
(C)  $2\frac{3}{8}$   
(D)  $2\frac{3}{4}$
24. If  $5(2x - 1) = 35$ , then  $x =$
- (A)  $-4$   
(B)  $\frac{1}{4}$   
(C)  $3$   
(D)  $4$
25. John has  $x$  marbles and Max has twice as many marbles as John. Max gives John 5 of his marbles. How many marbles does John now have?
- (A)  $x - 5$   
(B)  $x + 5$   
(C)  $2x - 5$   
(D)  $2x + 5$
26. If  $a = 3$  and  $ab = 6$ , then  $a^2 - b^2 =$
- (A)  $1$   
(B)  $2$   
(C)  $5$   
(D)  $13$
27. If  $A = \begin{pmatrix} 1 & 2 & 5 & 4 \\ 6 & 1 & 3 & 7 \\ -2 & 3 & 2 & 9 \end{pmatrix}$ , then the order of  $A$  is
- (A)  $2 \times 3$   
(B)  $3 \times 2$   
(C)  $3 \times 4$   
(D)  $4 \times 3$

28. The determinant of the identity matrix is

- (A) one  
 (B) zero  
 (C) undefined  
 (D) negative one

29. If the vectors  $\mathbf{p}$  and  $\mathbf{q}$  are  $\begin{bmatrix} 3 \\ 2 \end{bmatrix}$  and  $\begin{bmatrix} -1 \\ 4 \end{bmatrix}$  respectively, then  $\mathbf{p} - 2\mathbf{q}$  is

- (A)  $\begin{bmatrix} 1 \\ 10 \end{bmatrix}$   
 (B)  $\begin{bmatrix} 1 \\ -6 \end{bmatrix}$   
 (C)  $\begin{bmatrix} 5 \\ 10 \end{bmatrix}$   
 (D)  $\begin{bmatrix} 5 \\ -6 \end{bmatrix}$

Item 30 refers to the following diagram of triangle  $OLM$ , in which  $R$  is the midpoint of  $OL$  and  $T$  the midpoint of  $OM$ . Further,  $\vec{OR} = \mathbf{a}$  and  $\vec{OT} = \mathbf{b}$ .

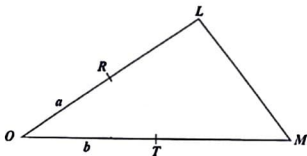

30.  $\vec{RM}$ , expressed in terms of  $\mathbf{a}$  and  $\mathbf{b}$ , is

- (A)  $2\mathbf{b} - \mathbf{a}$   
 (B)  $\mathbf{a} + 2\mathbf{b}$   
 (C)  $2(\mathbf{b} - \mathbf{a})$   
 (D)  $2(\mathbf{a} + \mathbf{b})$

31. Given that 1 millimetre =  $\frac{1}{1000}$  metres,

2 500 millimetres, in metres, is

- (A) 0.25  
 (B) 2.5  
 (C) 25  
 (D) 250

32. How many kilograms are there in one tonne?

- (A) 10  
 (B) 100  
 (C) 1 000  
 (D) 10 000

Item 33 refers to the following diagram of a trapezium,  $PQRS$ .

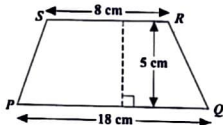

33. The area of the trapezium,  $PQRS$ , is

- (A)  $45 \text{ cm}^2$   
 (B)  $65 \text{ cm}^2$   
 (C)  $90 \text{ cm}^2$   
 (D)  $130 \text{ cm}^2$

34. At a party, a number of guests were served 15 litres of champagne. Each guest had 2 glasses of champagne and each glass held 150 millilitres. Assuming no spillage, how many guests were at the party?

- (A) 10  
 (B) 75  
 (C) 50  
 (D) 100

35. The perimeter of a square is 56 cm. What is its area, in  $\text{cm}^2$ ?
- (A) 28  
(B) 78  
(C) 169  
(D) 196

36. The circumference of a circle is 154 cm.

Given that  $\pi = \frac{22}{7}$ , the diameter of the circle, in cm, is

- (A) 7  
(B) 24.5  
(C) 49  
(D) 54

Item 37 refers to the following diagram which consists of a triangle resting on a square of side 7 cm.

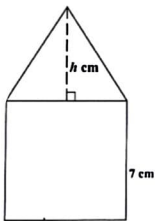

37. If the TOTAL area of the diagram is  $63 \text{ cm}^2$ , what is the value of  $h$ , the height of the triangle?
- (A) 2 cm  
(B) 4 cm  
(C) 5 cm  
(D) 9 cm

38. On leaving Trinidad, the time on a pilot's watch was 23:00 h. When he arrived at his destination in the same time zone on the next day, his watch showed 03:00 h. How many hours did the flight take?

- (A) 4  
(B) 16  
(C) 20  
(D) 26

39. Ms Clarke arranged the 15 test scores of her students in order of size and selected the 8th score for reporting purposes. Which of the following statistical measures did Ms Clarke obtain?

- (A) Mean  
(B) Mode  
(C) Range  
(D) Median

Items 40–41 refer to the following diagram which shows the cumulative frequency curve based on the marks of 200 students who took a driving test.

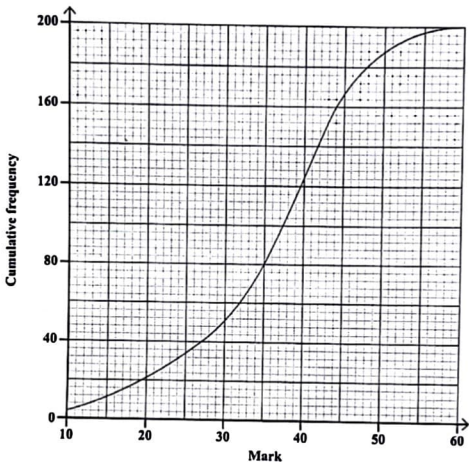

40. The median mark scored by the 200 students is

- (A) 30.0
- (B) 37.5
- (C) 40.0
- (D) 100.0

41. The highest mark scored in the test was

- (A) 50
- (B) 60
- (C) 180
- (D) 200

42. In a box, there are 8 red, 7 blue and 6 green marbles. One marble is picked up randomly. What is the probability that it is neither blue nor green?

- (A)  $\frac{8}{21}$   
 (B)  $\frac{3}{7}$   
 (C)  $\frac{9}{22}$   
 (D)  $\frac{2}{3}$

**Item 43** refers to the following pie chart which shows the popular games played by 720 students.

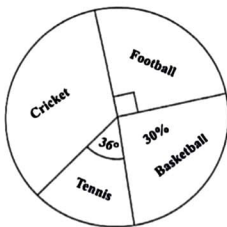

43. How many students played cricket?

- (A) 35  
 (B) 120  
 (C) 252  
 (D) 300

**Item 44** refers to the following two-way table, which shows the mode of transportation to school on a particular day, for a group of 200 students.

	Bus	Taxi	Walk	Total
Male	30	50	28	108
Female	44	16	32	92
Total	74	66	60	200

44. A male student is picked at random from the group. What is the probability that he does NOT walk to school on that day?

- (A)  $\frac{2}{5}$   
 (B)  $\frac{13}{18}$   
 (C)  $\frac{20}{27}$   
 (D)  $\frac{7}{10}$

45. The point where a linear function crosses the horizontal axis is

- (A) the  $y$ -intercept  
 (B) the  $x$ -intercept  
 (C) always positive  
 (D) always negative

46. The equation of the line which passes through the point (0, 5) and has a gradient of 4 is

- (A)  $y = 4x$   
 (B)  $y = 5x$   
 (C)  $y = 4x + 5$   
 (D)  $y = 5x + 4$

47. Which of the following graphs represents a linear function?

(A)

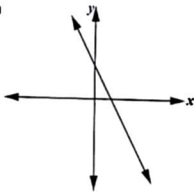

(B)

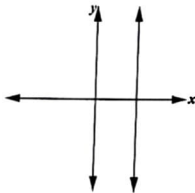

(C)

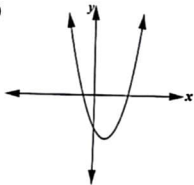

(D)

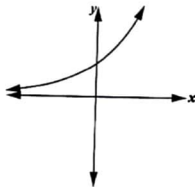

Item 48 refers to the following graph of a quadratic function.

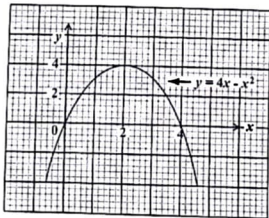

48. The coordinates of the turning point of the function  $y = 4x - x^2$  are

- (A) (4, 4)
- (B) (0, 4)
- (C) (4, 2)
- (D) (2, 4)

49. A line  $L$  is parallel to the line

$$3x - 7y - 9 = 0.$$

What is the gradient of the line  $L$ ?

- (A)  $-\frac{7}{3}$   
(B)  $-\frac{9}{7}$   
(C)  $\frac{3}{7}$   
(D)  $\frac{7}{3}$
50. If  $g(x) = \frac{7x-3}{5}$ , then  $g(-6) =$
- (A)  $-9$   
(B)  $-\frac{39}{5}$   
(C)  $\frac{39}{5}$   
(D)  $9$

**Item 51** refers to the following arrow diagram which shows a function,  $f$ .

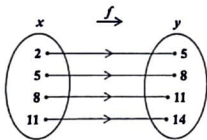

51. Which of the following BEST describes the function?

- (A)  $y = x + 3$   
(B)  $x + y = 3$   
(C)  $x = y + 3$   
(D)  $y = 2x + 1$

52. The range of  $f: x \rightarrow x^3$  for the domain  $\{-2, -1, 0, 1, 2\}$  is

- (A)  $\{8, 1, 0, 1, 8\}$   
(B)  $\{6, 3, 0, 3, 6\}$   
(C)  $\{-6, -3, 0, 3, 6\}$   
(D)  $\{-8, -1, 0, 1, 8\}$

**Item 53** refers to the following diagram of a transformation.

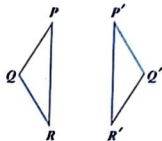

53. What transformation maps  $PQR$  onto  $P'Q'R'$ ?

- (A) Rotation  
(B) Reflection  
(C) Translation  
(D) Enlargement

54. In which of the following polygons does the sum of the measures of the interior angles equal the sum of the measures of the exterior angles?

- (A) Triangle  
(B) Hexagon  
(C) Pentagon  
(D) Quadrilateral

Item 55 refers to the following diagram of the straight line  $y = x$ .

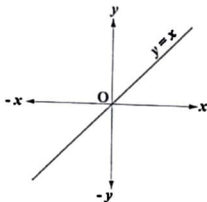

55. What is the image of the line  $y = x$  when it is rotated anticlockwise about O through an angle of  $90^\circ$ ?

- (A)  $y = 0$ .  
(B)  $x = 0$   
(C)  $y = x$   
(D)  $y = -x$

Item 56 refers to the following diagram of a translation.

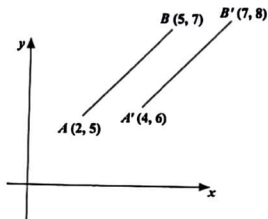

56. In the diagram, the translation by which  $AB$  is mapped onto  $A'B'$  is represented by

- (A)  $\begin{bmatrix} 1 \\ 1 \end{bmatrix}$   
(B)  $\begin{bmatrix} 2 \\ 1 \end{bmatrix}$   
(C)  $\begin{bmatrix} 3 \\ 2 \end{bmatrix}$   
(D)  $\begin{bmatrix} 5 \\ 3 \end{bmatrix}$

Item 57 refers to the following right-angled triangle,  $ABC$ .

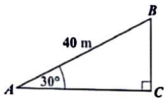

57. In the triangle, angle  $BAC = 30^\circ$  and  $AB = 40\text{ m}$ . The length  $BC$ , in metres, is
- (A)  $40 \sin 30^\circ$   
(B)  $40 \tan 30^\circ$   
(C)  $40 \sin 60^\circ$   
(D)  $40 \tan 60^\circ$

Item 58 refers to the following diagram of an enlargement.

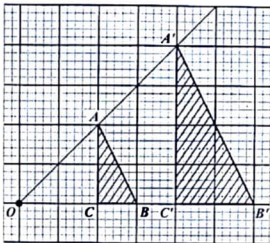

58.  $OAA'$ ,  $OBB'$  and  $OCC'$  are straight lines.  $\Delta ABC$  is mapped onto  $\Delta A'B'C'$  by an enlargement with centre  $O$ . What is the scale factor of the enlargement?
- (A)  $\frac{1}{2}$   
(B)  $-\frac{1}{2}$   
(C)  $2$   
(D)  $-2$

59. A plane is flying in a direction of  $045^\circ$  and changes course in a clockwise direction to  $135^\circ$ . The angle through which the plane turns is
- (A)  $45^\circ$   
(B)  $90^\circ$   
(C)  $135^\circ$   
(D)  $270^\circ$
60. In a triangle,  $PQR$ , angle  $P = x^\circ$  and angle  $Q = 2x^\circ$ . What is the size of angle  $R$ ?
- (A)  $60^\circ$   
(B)  $45^\circ$   
(C)  $\left(\frac{180}{3x}\right)$   
(D)  $(180^\circ - 3x^\circ)$

**END OF TEST**

**IF YOU FINISH BEFORE TIME IS CALLED, CHECK YOUR WORK ON THIS TEST.**

**CANDIDATE – PLEASE NOTE!**

PRINT your name on the line below and return this booklet with your answer sheet. Failure to do so may result in disqualification.

**TEST CODE 01234010**
**FORM TP 2022018**
**JANUARY 2022**

**CARIBBEAN EXAMINATIONS COUNCIL  
CARIBBEAN SECONDARY EDUCATION CERTIFICATE®  
EXAMINATION**

**MATHEMATICS**

**Paper 01 – General Proficiency**

*1 hour 30 minutes*

**04 JANUARY 2022 (p.m.)**

**READ THE FOLLOWING INSTRUCTIONS CAREFULLY.**

- This test consists of 60 items. You will have 1 hour and 30 minutes to answer them.
- In addition to this test booklet, you should have an answer sheet.
- A list of formulae is provided on page 2 of this booklet.**
- Each item in this test has four suggested answers lettered (A), (B), (C), (D). Read each item you are about to answer and decide which choice is best.
- On your answer sheet, find the number which corresponds to your item and shade the space having the same letter as the answer you have chosen. Look at the sample item below.

Sample Item

$$2a + 6a =$$

- (A)  $8a$   
 (B)  $8a^2$   
 (C)  $12a$   
 (D)  $12a^2$

Sample Answer

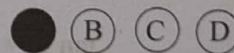

The best answer to this item is “ $8a$ ”, so (A) has been shaded.

- If you want to change your answer, erase it completely before you fill in your new choice.
- When you are told to begin, turn the page and work as quickly and as carefully as you can. If you cannot answer an item, go on to the next one. You may return to that item later.
- You may do any rough work in this booklet.
- Calculators and mathematical tables are NOT allowed for this paper.
- ALL diagrams in this booklet are NOT drawn to scale, unless otherwise stated.

**DO NOT TURN THIS PAGE UNTIL YOU ARE TOLD TO DO SO.**

Copyright © 2021 Caribbean Examinations Council  
All rights reserved.

01234010/J/CSEC 2022

1. What percentage of 40 is 8?
- (A) 5
  - (B) 20
  - (C) 32
  - (D) 150

2. The number 3.14063 written correct to 3 decimal places is
- (A) 3.140
  - (B) 3.141
  - (C) 3.146
  - (D) 3.150

3. If  $4.3 \times 0.37 = 1.591$ , then  $0.43 \times 370$  is
- (A) 1.591
  - (B) 15.91
  - (C) 159.1
  - (D) 1591.0

4. The first 3 common multiples of 3, 4 and 6 are
- (A) 0, 1, 2
  - (B) 3, 4, 6
  - (C) 6, 8, 12
  - (D) 12, 24, 36

5. If \$350 is shared in the ratio 2:5, the SMALLER share is
- (A) \$ 50
  - (B) \$ 70
  - (C) \$100
  - (D) \$150

6. There are 40 students in a class. Girls make up 60% of the class. 25% of the girls wear glasses. How many girls in the class wear glasses?

- (A) 6
- (B) 8
- (C) 10
- (D) 15

7. If the universal set  $U = \{1, 2, 3, 4, 5, 6\}$  and  $H = \{3, 4, 6\}$ , then  $H' =$
- (A)  $\{1, 3, 5\}$
  - (B)  $\{1, 2, 5\}$
  - (C)  $\{2, 4, 6\}$
  - (D)  $\{3, 4, 6\}$

8. Which of the following statements describes the set of integers greater than -3 but less than 6?

- (A)  $\{x : -3 > x > 6, x \in Z\}$
- (B)  $\{x : -3 \geq x \geq 6, x \in Z\}$
- (C)  $\{x : -3 \leq x \leq 6, x \in Z\}$
- (D)  $\{x : -3 < x < 6, x \in Z\}$

9. If  $X$  and  $Y$  are 2 finite sets such that  $n(X) = 9$ ,  $n(X \cap Y) = 4$  and  $n(X \cup Y) = 15$ , then  $n(Y)$  is

- (A) 5
- (B) 6
- (C) 10
- (D) 12



Item 10 refers to the following Venn diagram.

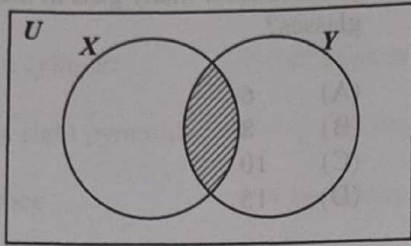

10. In the Venn diagram,  $X$  represents the set of factors of 12.  $Y$  represents the set of factors of 9. The shaded region represents the set of all factors of

- (A) 3
- (B) 6
- (C) 21
- (D) 108

11. The 30 students in Teacher May's class have either a dog ( $D$ ) or a cat ( $C$ ), or none of the two. ALL the students who have a cat also have a dog. If  $n(C) = 12$  and  $n(D) = 16$ , which of the following Venn diagrams correctly represents this information?

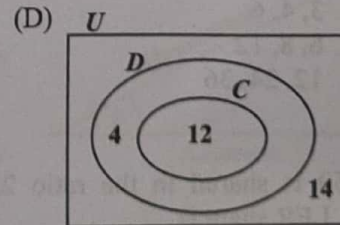
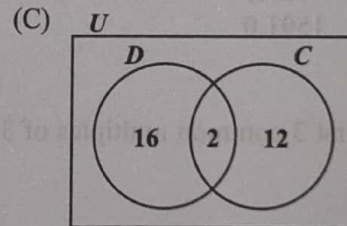
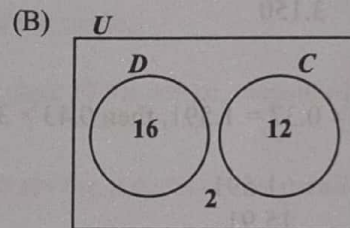
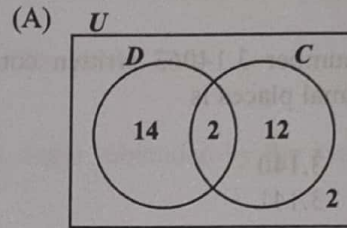

12. Which of the following pairs of sets is an example of disjoint sets?

- (A)  $E = \{\text{even numbers}\}$  and  $F = \{\text{odd numbers}\}$
- (B)  $P = \{\text{multiples of 2}\}$  and  $Q = \{\text{multiples of 3}\}$
- (C)  $X = \{\text{whole numbers}\}$  and  $Y = \{\text{rational numbers}\}$
- (D)  $G = \{\text{multiples of five}\}$  and  $H = \{\text{multiples of ten}\}$

13. If EC\$2.50 is equivalent to US\$1.00, then EC\$20.00 in US dollars is
- (A) \$ 5.00
  - (B) \$ 8.00
  - (C) \$50.00
  - (D) \$80.00
14. At a store, 3 cents on every dollar spent is charged as sales tax. How much is paid as sales tax on a costume which costs \$196.00?
- (A) \$ 5.88
  - (B) \$ 17.64
  - (C) \$190.12
  - (D) \$201.88
15. The cash price of a television set is \$350. When bought on hire purchase, a deposit of \$35 is required, followed by 12 monthly payments of \$30. How much is saved by paying cash?
- (A) \$10
  - (B) \$25
  - (C) \$40
  - (D) \$45
16. A company employs 20 persons as gardeners and clerks. The **mean** daily wage of ALL the employees is \$22.40. If EACH of the 12 gardeners is paid \$26.00 per day, then the daily amount paid to each of the 8 clerks is
- (A) \$ 3.60
  - (B) \$17.00
  - (C) \$24.20
  - (D) \$48.40
17. Delano invests \$5 000 for 2 years in an investment scheme. The investment earns compound interest of 8% per annum. What will be the amount of Delano's investment at the end of the two-year period?
- (A) \$ 800
  - (B) \$ 832
  - (C) \$5 800
  - (D) \$5 832
18. A car presently valued at \$12 000 depreciates at the rate of 10% per annum. What will be the value of the car one year later?
- (A) \$10 800
  - (B) \$11 800
  - (C) \$11 880
  - (D) \$13 200
19. A man's basic wage for a 40-hour week is \$160.00. He is paid \$5.00 per hour for overtime. If he works  $6\frac{1}{2}$  hours overtime in a certain week, then his wage for that week is
- (A) \$165.00
  - (B) \$166.50
  - (C) \$171.50
  - (D) \$192.50
20. A salesman sells a car for \$10 500. If he is paid a commission of 5% for the first \$10 000 and 8% on the remainder, then the TOTAL commission he receives is
- (A) \$525
  - (B) \$540
  - (C) \$545
  - (D) \$565
21. Althea normally saves \$x each month but in June she saved \$4 more than twice her usual amount. In June, she saved
- (A) \$4x
  - (B) \$6x
  - (C) \$2x + 4
  - (D) \$2(x + 4)

GO ON TO THE NEXT PAGE



22. If  $m * n = \sqrt{m^3 - n^2}$ , then  $5 * 2 =$
- (A) 2
  - (B)  $\sqrt{11}$
  - (C)  $\sqrt{34}$
  - (D) 11

Item 23 refers to the following diagram of a trapezium.

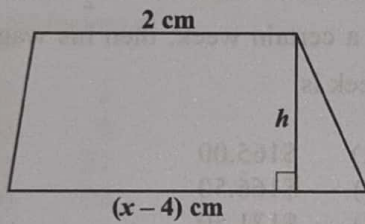

23. The trapezium with height,  $h$ , has an area of  $x^2 \text{ cm}^2$ . The equation that may be used to find the value of  $x$  is
- (A)  $x^2 = \frac{h}{2}(x - 2)$
  - (B)  $x^2 = 2h(x - 4)$
  - (C)  $x^2 = \frac{h}{2}(x - 6)$
  - (D)  $x^2 = h(x - 4)(x + 2)$

24.  $-(-2q) - 3q =$
- (A)  $-6q$
  - (B)  $-5q$
  - (C)  $-q$
  - (D)  $5q$

25.  $5^{n+1} \times 5^{n+2}$  is the same as
- (A)  $5^{2n}$
  - (B)  $5^{2n+3}$
  - (C)  $5^{3(2n)}$
  - (D)  $2 \times 5^{2n}$

26. If  $5(y - 2) - 3(y + 4) = 0$ , then  $y$  is
- (A) -1
  - (B) 3
  - (C) 7
  - (D) 11

Item 27 refers to the following vectors,  $p$  and  $q$ .

$$p = \begin{pmatrix} 3 \\ 7 \end{pmatrix} \quad q = \begin{pmatrix} -2 \\ 5 \end{pmatrix}$$

27. The vector  $p - q$  is represented by
- (A)  $\begin{pmatrix} 1 \\ 12 \end{pmatrix}$
  - (B)  $\begin{pmatrix} 5 \\ 12 \end{pmatrix}$
  - (C)  $\begin{pmatrix} 5 \\ 2 \end{pmatrix}$
  - (D)  $\begin{pmatrix} 1 \\ 5 \end{pmatrix}$

Item 28 refers to the following diagram of a parallelogram, in which  $EF$  is parallel to  $HG$ ,  $EH$  is parallel to  $FG$ ,  $\vec{EF} = k$  and  $\vec{EH} = m$ .

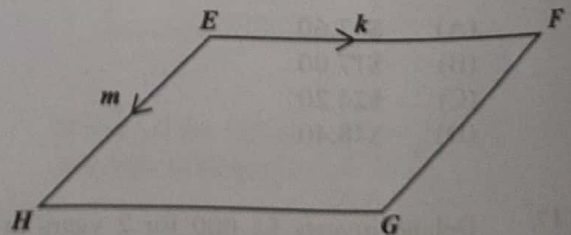

28.  $\vec{EG}$  expressed in terms of  $k$  and  $m$  is
- (A)  $k + m$
  - (B)  $k - m$
  - (C)  $m - k$
  - (D)  $-m - k$

29. If  $5 \begin{pmatrix} x \\ y \end{pmatrix} = 4 \begin{pmatrix} 10 \\ 20 \end{pmatrix}$ , then the values of  $x$  and  $y$  are

- (A)  $x = 4, y = 5$
- (B)  $x = 8, y = 16$
- (C)  $x = 2.5, y = 4$
- (D)  $x = 10, y = 20$

Item 30 refers to the following matrices,  $A$  and  $B$ .

$$A = \begin{pmatrix} 1 & 3 & -3 \\ 3 & 0 & 5 \end{pmatrix}, \quad B = \begin{pmatrix} 3 & 0 \\ 2 & 1 \\ 0 & 5 \end{pmatrix}$$

30. The matrix product  $AB$  is

- (A)  $\begin{pmatrix} -12 & -6 \\ 25 & 9 \end{pmatrix}$
- (B)  $\begin{pmatrix} -6 & -12 \\ 9 & 25 \end{pmatrix}$
- (C)  $\begin{pmatrix} 9 & -18 \\ 9 & 25 \end{pmatrix}$
- (D)  $\begin{pmatrix} 9 & -12 \\ 9 & 25 \end{pmatrix}$

31. If it took a speedboat 9 hours to travel a distance of 1 080 km, what was its average speed, in  $\text{kmh}^{-1}$ ?

- (A) 12
- (B) 102
- (C) 120
- (D) 1 200

Item 32 refers to the following diagram of a trapezium.

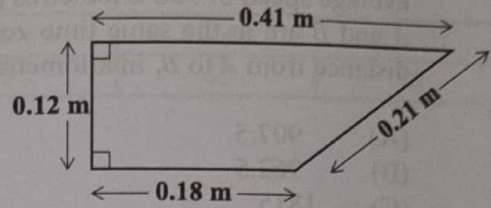

32. The perimeter of the trapezium, in millimetres (mm), is

- (A) 0.092
- (B) 9.2
- (C) 92
- (D) 920

Item 33 refers to the following circle, with centre  $O$ .

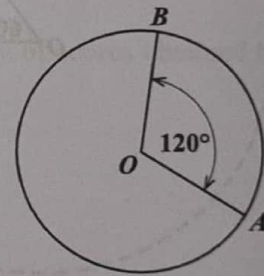

33. If the circumference of the circle is 15 cm, then the length of the minor arc  $AB$ , in cm, is

- (A)  $\frac{360}{120} \times 15$
- (B)  $\frac{120}{360} \times 15$
- (C)  $\frac{360}{360 - 120} \times 15$
- (D)  $\frac{360 - 120}{360} \times 15$

GO ON TO THE NEXT PAGE

34. An aircraft leaves  $A$  at 16:00 hours and arrives at  $B$  at 19:30 hours, travelling at an average speed of 550 kilometres per hour.  $A$  and  $B$  are in the same time zone. The distance from  $A$  to  $B$ , in kilometres, is

- (A) 907.5
- (B) 962.5
- (C) 1815
- (D) 1925

Item 35 refers to the following diagram which shows a circle, with centre  $O$ , a sector and the major and minor arcs indicated.

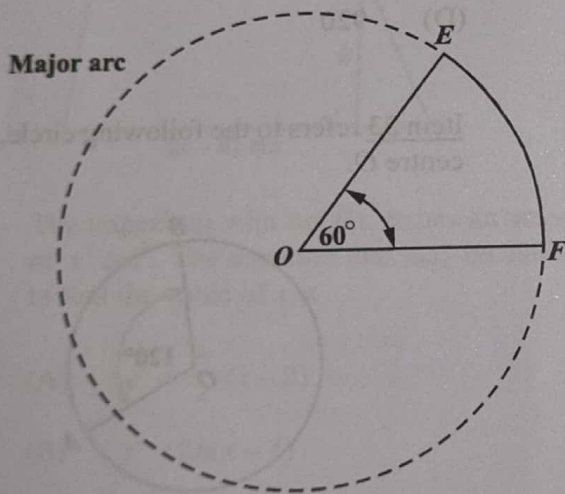

35. The length of the major arc,  $FE$ , is 40 cm. What is the circumference of the circle, in cm?

- (A) 24
- (B) 48
- (C) 50
- (D) 64

Item 36 refers to the following diagram which shows a cuboid.

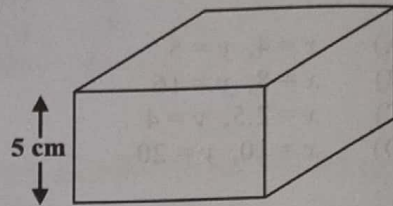

36. The volume of the cuboid is  $320 \text{ cm}^3$  and the height is 5 cm. If the cuboid has a square base, what is the length of one side of the base?

- (A) 8 cm
- (B) 16 cm
- (C) 32 cm
- (D) 64 cm

37. The area of a triangle is  $60 \text{ cm}^2$  and its base is 12 cm. What is the perpendicular height of the triangle, in cm?

- (A) 5
- (B) 10
- (C) 13
- (D) 17

38. A square has the same area as a rectangle with sides of length 9 cm and 16 cm. What is the length of the side of the square?

- (A) 9 cm
- (B) 12 cm
- (C) 12.5 cm
- (D) 75 cm

Items 39 and 40 refer to the following frequency distribution which shows the average mass, in kg, of a group of children in a school.

Mass (kg)	21–30	31–40	41–50	51–60	61–70
Frequency	15	35	24	40	18

39. The upper limit of the modal class is
- (A) 31
  - (B) 41
  - (C) 60
  - (D) 70
40. How many children have a mass GREATER than 40 kg?
- (A) 15
  - (B) 35
  - (C) 60
  - (D) 82

Item 41 refers to the following table which shows the frequency of scores obtained by students on a test.

Scores	2	3	5	6	8	11
Students	8	4	6	3	12	2

41. The modal score is
- (A) 8
  - (B) 9
  - (C) 10
  - (D) 12

GO ON TO THE NEXT PAGE



Item 42 refers to the following diagram of a cumulative frequency curve which shows the marks obtained by 200 students on a test.

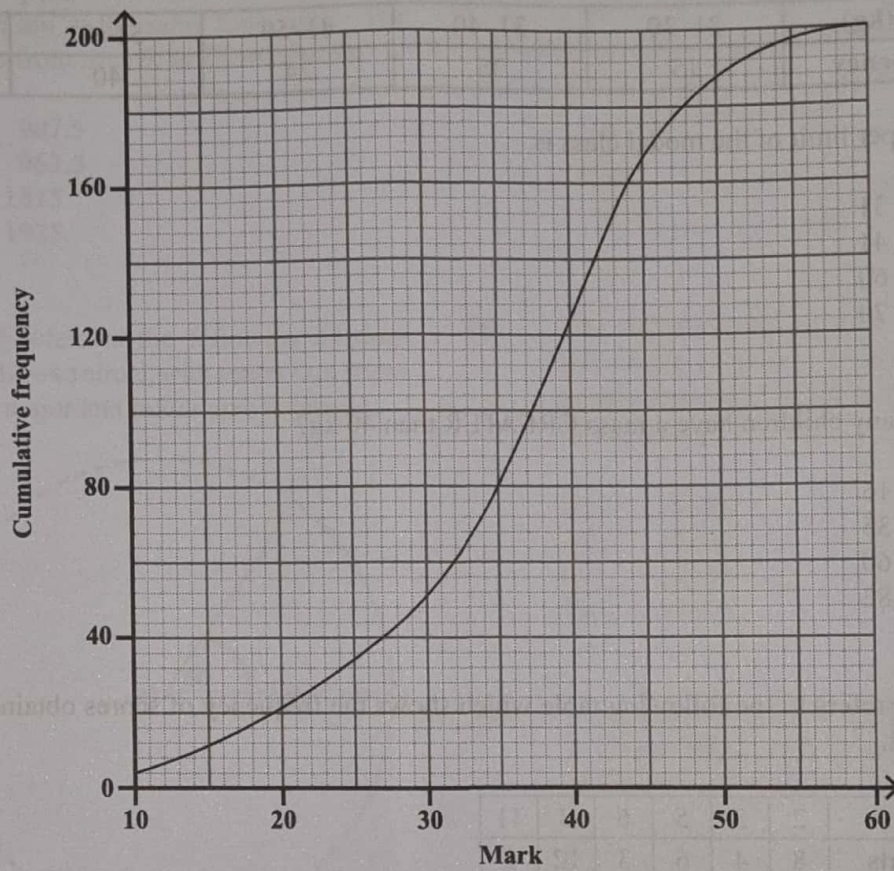

42. The median of the marks scored by the 200 students is

- (A) 30.0
- (B) 35.0
- (C) 37.5
- (D) 100.0

Item 43 refers to the following bar chart which shows the ages of children who took part in a survey.

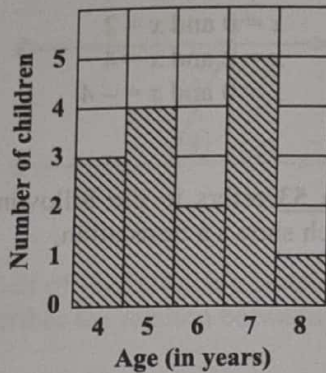

43. How many children took part in the survey?
- (A) 5  
 (B) 15  
 (C) 75  
 (D) 87

44. Six hundred students write an examination. The probability of a randomly selected student failing the examination is  $\frac{1}{5}$ . How many students are expected to pass?

- (A) 100  
 (B) 120  
 (C) 480  
 (D) 500

45. Which of the following equations represents a linear function?

- (A)  $xy = 4$   
 (B)  $y + 4 = x^2$   
 (C)  $y + 3 = 2x$   
 (D)  $y = x^2 + 2x - 5$

46. The set of ordered pairs below represents a relation that is a function.

$$\{(2, 7), (-4, 6), (10, 4)\}$$

Which of the following points, when added to the set, would form a relation that is NOT a function?

- (A) (2, 8)  
 (B) (1, 3)  
 (C) (0, -4)  
 (D) (-8, 10)

Item 47 refers to the following arrow diagram.

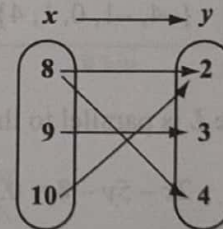

47. The arrow diagram above describes the relation

- (A)  $y$  is more than  $x$   
 (B)  $y$  is a multiple of  $x$   
 (C)  $x$  is a factor of  $y$   
 (D)  $x$  is a multiple of  $y$

GO ON TO THE NEXT PAGE

48. What is the gradient of the straight line  $2y = -3x - 8$ ?

- (A) 2
- (B) 3
- (C)  $-\frac{3}{2}$
- (D) -3

49. If  $h(x) = \frac{3x-2}{5}$ , then  $h(-6) =$

- (A) -4
- (B)  $-\frac{16}{5}$
- (C)  $\frac{16}{5}$
- (D) 4

50. The range of  $f: x \rightarrow -x^2$  for the domain  $\{-2, -1, 0, 1, 2\}$  is

- (A)  $\{1, 4\}$
- (B)  $\{-4, -1, 0\}$
- (C)  $\{-4, -1, 1, 4\}$
- (D)  $\{-4, -1, 0, 1, 4\}$

51. A line  $L$  is parallel to the line

$$2x - 5y - 8 = 0.$$

What is the gradient of the line  $L$ ?

- (A)  $-\frac{5}{2}$
- (B)  $-\frac{2}{5}$
- (C)  $\frac{2}{5}$
- (D) 2

52. The values of  $x$  at the points where  $y = 4x - x^2$  intersects  $y = 0$  are

- (A)  $x = 0$  and  $x = 4$
- (B)  $x = 0$  and  $x = 2$
- (C)  $x = 2$  and  $x = 4$
- (D)  $x = 0$  and  $x = -4$

Item 53 refers to the following diagram which shows a translation.

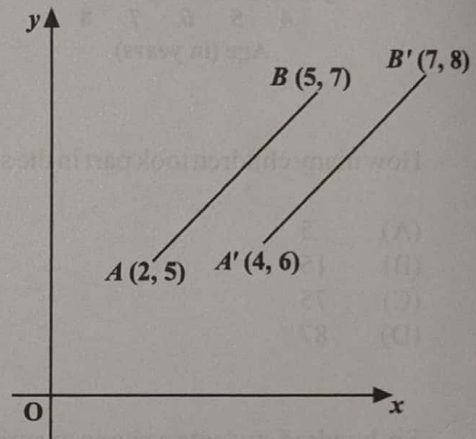

53. In the diagram, the translation by which  $AB$  is mapped onto  $A'B'$  is represented by

- (A)  $\begin{pmatrix} 1 \\ 1 \end{pmatrix}$
- (B)  $\begin{pmatrix} 2 \\ 1 \end{pmatrix}$
- (C)  $\begin{pmatrix} 3 \\ 2 \end{pmatrix}$
- (D)  $\begin{pmatrix} 5 \\ 3 \end{pmatrix}$

GO ON TO THE NEXT PAGE

Item 54 refers to the following transversal diagram in which  $PQ$  and  $RS$  are parallel.

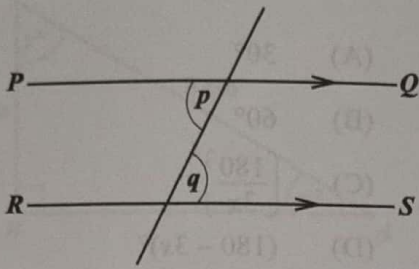

54. Which of the following statements BEST describes the relation between  $p$  and  $q$ ?

- (A)  $p = q$
- (B)  $p < q$
- (C)  $p + q = 90^\circ$
- (D)  $p + q = 180^\circ$

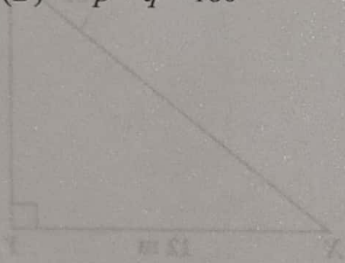

55. A ship sailed 8 km due east from  $A$  to  $B$ . It then sailed 6 km due north to  $C$ . Which of the following diagrams BEST represents the path of the ship?

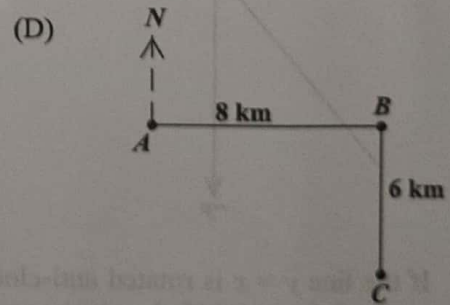
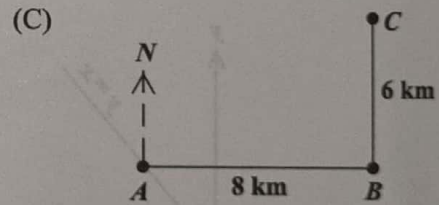
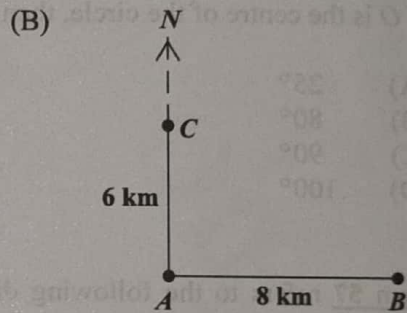
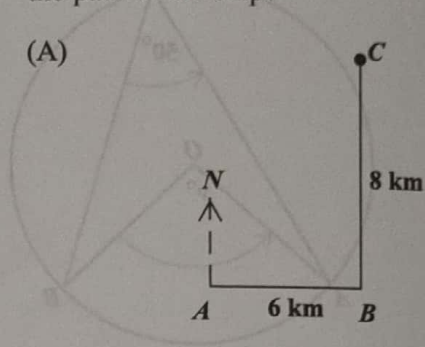

Item 56 refers to the following diagram of a circle.

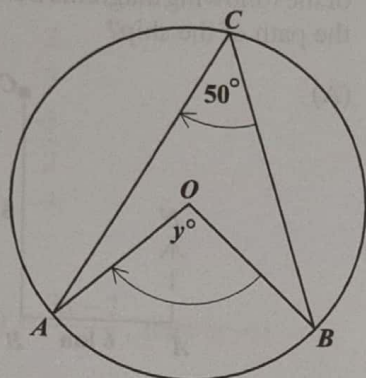

56. If  $O$  is the centre of the circle, then  $y^\circ$  is

- (A)  $25^\circ$
- (B)  $80^\circ$
- (C)  $90^\circ$
- (D)  $100^\circ$

Item 57 refers to the following diagram which shows the graph of the line  $y = x$ .

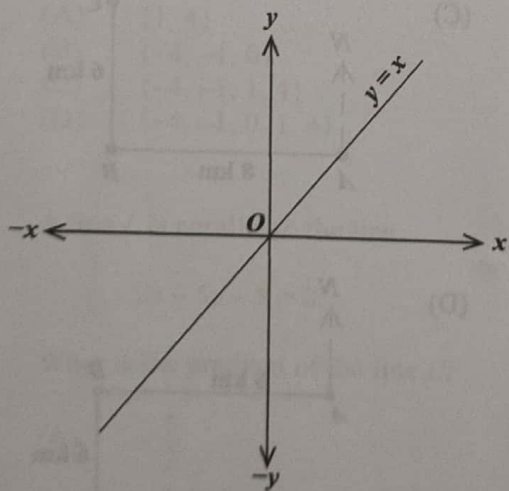

57. If the line  $y = x$  is rotated anti-clockwise about  $O$  through  $90^\circ$ , then its image is

- (A)  $y = -x$
- (B)  $x = y$
- (C)  $x = 0$
- (D)  $y = 0$

58. In triangle  $ABC$ , angle  $A = x^\circ$  and angle  $B = 2x^\circ$ . What is the size of angle  $C$ ?

- (A)  $30^\circ$
- (B)  $60^\circ$
- (C)  $\left(\frac{180}{3x}\right)^\circ$
- (D)  $(180 - 3x)^\circ$

Item 59 refers to the following diagram which shows that the angle of depression of a point  $X$  from  $Z$  is  $35^\circ$ .

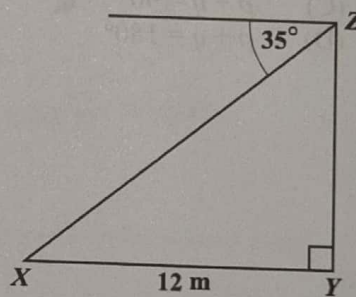

59. If  $X$  is 12 metres from  $Y$ , then the height,  $YZ$ , in metres, is

- (A)  $12 \cos 35^\circ$
- (B)  $12 \sin 35^\circ$
- (C)  $12 \tan 35^\circ$
- (D)  $12 \cos 55^\circ$

Item 60 refers to the following right-angled triangle.

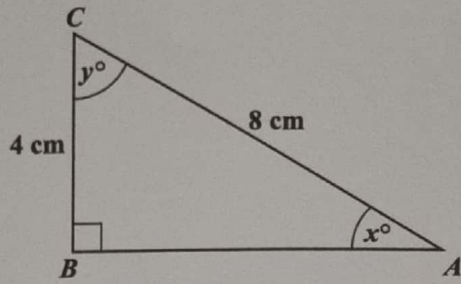

60. Which trigonometric ratio is equal to  $\frac{4}{8}$ ?
- (A)  $\sin x$
  - (B)  $\tan y$
  - (C)  $\cos x$
  - (D)  $\tan x$

END OF TEST

IF YOU FINISH BEFORE TIME IS CALLED, CHECK YOUR WORK ON THIS TEST.

**LIST OF FORMULAE**

Volume of a prism  $V = Ah$  where  $A$  is the area of the cross-section and  $h$  is the perpendicular length.

Volume of a cylinder  $V = \pi r^2 h$  where  $r$  is the radius of the base and  $h$  is the perpendicular height.

Volume of a right pyramid  $V = \frac{1}{3} Ah$  where  $A$  is the area of the base and  $h$  is the perpendicular height.

Circumference  $C = 2\pi r$  where  $r$  is the radius of the circle.

Arc length  $S = \frac{\theta}{360} \times 2\pi r$  where  $\theta$  is the angle subtended by the arc, measured in degrees.

Area of a circle  $A = \pi r^2$  where  $r$  is the radius of the circle.

Area of a sector  $A = \frac{\theta}{360} \times \pi r^2$  where  $\theta$  is the angle of the sector, measured in degrees.

Area of a trapezium  $A = \frac{1}{2} (a + b) h$  where  $a$  and  $b$  are the lengths of the parallel sides and  $h$  is the perpendicular distance between the parallel sides.

Roots of quadratic equations If  $ax^2 + bx + c = 0$ ,

$$\text{then } x = \frac{-b \pm \sqrt{b^2 - 4ac}}{2a}$$

Trigonometric ratios  $\sin \theta = \frac{\text{length of opposite side}}{\text{length of hypotenuse}}$

$$\cos \theta = \frac{\text{length of adjacent side}}{\text{length of hypotenuse}}$$

$$\tan \theta = \frac{\text{length of opposite side}}{\text{length of adjacent side}}$$

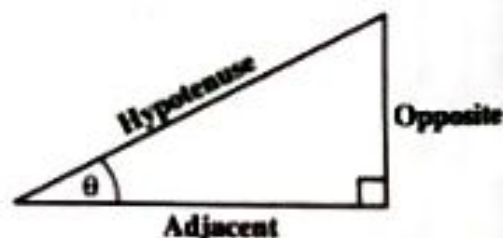

Area of a triangle Area of  $\Delta = \frac{1}{2} bh$  where  $b$  is the length of the base and  $h$  is the perpendicular height.

$$\text{Area of } \Delta ABC = \frac{1}{2} ab \sin C$$

$$\text{Area of } \Delta ABC = \sqrt{s(s-a)(s-b)(s-c)}$$

$$\text{where } s = \frac{a+b+c}{2}$$

Sine rule  $\frac{a}{\sin A} = \frac{b}{\sin B} = \frac{c}{\sin C}$

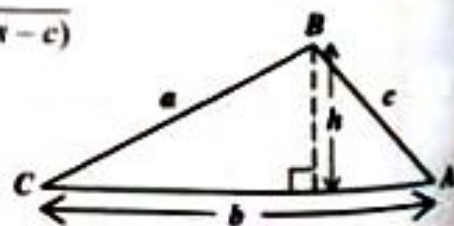

Cosine rule  $a^2 = b^2 + c^2 - 2bc \cos A$

1.  $(-3)^2 + (-2)^2$  is equal to
- (A) -13  
(B) -10  
(C) 5  
(D) 13
2. What is the value of the digit 2 in the number 48.621?
- (A)  $\frac{2}{100}$   
(B)  $\frac{2}{10}$   
(C) 2  
(D) 200
3. What number when added to  $1\frac{1}{3}$  gives 2?
- (A)  $\frac{1}{3}$   
(B)  $\frac{2}{3}$   
(C) 1  
(D) 3
4. The next term in the sequence 1, 6, 13, 22, 33, \_\_\_\_\_ is
- (A) 44  
(B) 45  
(C) 46  
(D) 52
5. If 30% of a number is 45, what is  $\frac{4}{5}$  of the number?
- (A) 36  
(B) 120  
(C) 150  
(D) 180
6. A certain amount of money is shared in the ratio 2:3:9. If the difference between the first and second shares is \$40, then the amount of money shared is
- (A) \$280  
(B) \$360  
(C) \$400  
(D) \$560
7. If  $P = \{2, 3, 5, 7\}$ ,  
 $Q = \{2, 3, 6\}$  and  
 $S = \{2, 4, 5\}$ ,  
then  $P \cap Q \cap S =$
- (A) {2}  
(B) {2,3}  
(C) {2, 3, 5}  
(D) {2, 3, 4, 5, 6, 7}
- Item 8** refers to the following Venn diagram.

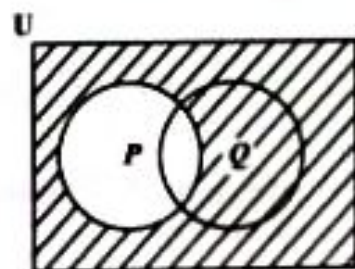

8. The shaded region represents
- (A)  $P'$   
(B)  $(P \cup Q)'$   
(C)  $P \cup Q'$   
(D)  $Q \cap P'$

GO ON TO THE NEXT PAGE

9. The elements of the set  $\{x: 6 \leq x < 10, \text{ where } x \text{ is an integer}\}$  are
- (A)  $\{7, 8, 9\}$
  - (B)  $\{6, 7, 8, 9\}$
  - (C)  $\{7, 8, 9, 10\}$
  - (D)  $\{6, 7, 8, 9, 10\}$

Item 10 refers to the following information.

$$M = \{p, q, r\}$$

$$N = \{p, q\}$$

10. Which of the following statements is true?
- (A)  $M \subset N$
  - (B)  $M \cap N = N$
  - (C)  $M \cup N = N$
  - (D)  $M \cap N = \{ \}$

Item 11 refers to the the following information which describes 3 sets.

$P = \{\text{Prime numbers}\}$

$Q = \{\text{Odd numbers}\}$

$R = \{\text{Even numbers}\}$

11. Which of the following sets is empty?
- (A)  $P \cap R$
  - (B)  $P \cup Q$
  - (C)  $P \cap Q$
  - (D)  $Q \cap R$

Item 12 refers to the following Venn diagram which shows the universal set  $U$ , and two sets,  $T$  and  $C$ , that represent the students in a class who play tennis ( $T$ ) and chess ( $C$ ).



12. How many students play EXACTLY one game?
- (A) 2
  - (B) 3
  - (C) 4
  - (D) 6
13. A dress which costs \$180.00 is being sold at a discount of 10%. The amount of the discount is
- (A) \$ 1.80
  - (B) \$ 10.00
  - (C) \$ 18.00
  - (D) \$170.00
14. The cost of a refrigerator is \$1 850.00. If a sales tax of 5% is paid on the cost price of the refrigerator, a buyer who purchases the refrigerator by cash will pay
- (A) \$1 350.00
  - (B) \$1 757.50
  - (C) \$1 845.00
  - (D) \$1 942.50

15. A salesman sells a car for \$11 000. If he is paid a commission of 4.5% for the first \$10 000 and 7.5% on the remainder, then the commission he receives is
- (A) \$ 495  
 (B) \$ 525  
 (C) \$ 825  
 (D) \$1 320
16. The value of a plot of land is \$18 000.00. Land tax is charged at the rate of \$0.70 per \$100.00 value. What is the TOTAL amount of tax paid for the land?
- (A) \$110.00  
 (B) \$126.00  
 (C) \$180.70  
 (D) \$257.15
17. A man's basic wage for a 40-hour week is \$160.00. He is paid overtime at the rate of  $1\frac{1}{4}$  times the hourly rate. If he works  $6\frac{1}{2}$  hours overtime in a certain week, his wage for that week is
- (A) \$165.00  
 (B) \$166.50  
 (C) \$171.50  
 (D) \$192.50
18. At the end of any year a car is worth 5% less than what it was worth at the beginning of the year. If a car was worth \$9 500 in December 2016, then its value in January 2016 was
- (A) \$ 9 025  
 (B) \$ 9 995  
 (C) \$10 000  
 (D) \$10 025
19. A loan of \$8 000 was repaid in 24 equal monthly instalments of \$400. The rate of interest on the loan was
- (A) 5%  
 (B)  $8\frac{1}{3}\%$   
 (C)  $16\frac{1}{3}\%$   
 (D) 20%
20. At a sale, each book was marked \$3.00 off the original price. Daniel paid \$46.00 for 2 books that had the same sale price. What was the **original** cost of ONE of his books?
- (A) \$20.00  
 (B) \$21.50  
 (C) \$24.50  
 (D) \$26.00
21.  $3x^2 \times 2x^3 =$
- (A)  $6x^3$   
 (B)  $5x^3$   
 (C)  $6x^6$   
 (D)  $72x^5$
22. If  $5(2x - 1) = 35$ , then  $x =$
- (A) -4  
 (B)  $\frac{1}{4}$   
 (C) 3  
 (D) 4

GO ON TO THE NEXT PAGE

23. When twice a certain number is subtracted from 7 and the result is multiplied by 3, the answer is 33. What is the original number?

(A) -3  
(B) -2  
(C) 2  
(D) 9

24. Given that  $3 * 6 = 12$  and  $2 * 5 = 9$ , then  $a * b$  may be defined as

(A)  $4(b - a)$   
(B)  $a^2 - b$   
(C)  $6a - b$   
(D)  $2a + b$

25. If  $x = -2$ ,  $y = 3$ ,  $t = 2$ , then  $\left(\frac{x}{y}\right)^t =$

(A)  $-\frac{4}{9}$   
(B)  $\frac{4}{9}$   
(C)  $\frac{4}{3}$   
(D)  $\frac{9}{4}$

26. If  $3^{2x+1} = 9(3^x)$ , then the value of  $x$  is

(A) 0  
(B)  $\frac{1}{3}$   
(C) 1  
(D) 3

27. Given that  $A = \begin{bmatrix} 1 & 3 & -3 \\ 3 & 0 & 5 \end{bmatrix}$ , then  $3A$  equals

(A)  $\begin{bmatrix} 3 & 9 & -9 \\ 9 & 0 & 15 \end{bmatrix}$

(B)  $\begin{bmatrix} 4 & 6 & -6 \\ 6 & 3 & 8 \end{bmatrix}$

(C)  $\begin{bmatrix} 3 & 9 & -6 \\ 9 & 0 & 15 \end{bmatrix}$

(D)  $\begin{bmatrix} -2 & 0 & 6 \\ 0 & 3 & 2 \end{bmatrix}$

28. The determinant of the  $2 \times 2$  identity matrix is

(A) one  
(B) zero  
(C) undefined  
(D) negative one

Item 29 refers to the following vectors,  $\mathbf{p}$  and  $\mathbf{q}$ .

$$\mathbf{p} = \begin{bmatrix} 3 \\ 7 \end{bmatrix} \quad \mathbf{q} = \begin{bmatrix} -2 \\ 5 \end{bmatrix}$$

29. The vector  $\mathbf{p} - \mathbf{q}$  is represented by

(A)  $\begin{bmatrix} 1 \\ 12 \end{bmatrix}$

(B)  $\begin{bmatrix} 5 \\ 12 \end{bmatrix}$

(C)  $\begin{bmatrix} 5 \\ 2 \end{bmatrix}$

(D)  $\begin{bmatrix} 1 \\ 5 \end{bmatrix}$

**Item 30** refers to the following parallelogram,  $WXYZ$ . In the parallelogram,  $\vec{XY} = u$  and  $\vec{XW} = v$ .  $R$  is the midpoint of  $YZ$ .

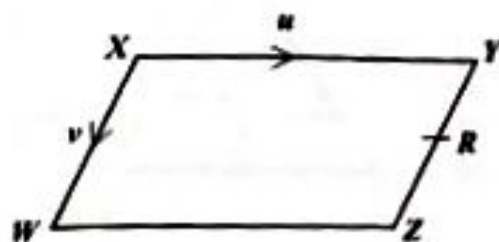

30.  $\vec{WR}$ , expressed in terms of  $u$  and  $v$ , is

- (A)  $u - \frac{1}{2}v$   
 (B)  $u + \frac{1}{2}v$   
 (C)  $-u + \frac{1}{2}v$   
 (D)  $-\frac{1}{2}v - u$

31. Given that 1 millimetre =  $\frac{1}{1000}$  metres, then 2 500 millimetres, in metres, is

- (A) 0.25  
 (B) 2.5  
 (C) 25  
 (D) 250

32. The volume, in  $\text{cm}^3$ , of a cube of edge 3 cm is

- (A) 9  
 (B) 18  
 (C) 27  
 (D) 54

33. The perimeter of a square is 48 cm. What is its area, in  $\text{cm}^2$ ?

- (A) 36  
 (B) 72  
 (C) 108  
 (D) 144

**Item 34** refers to the following diagram of a trapezium.

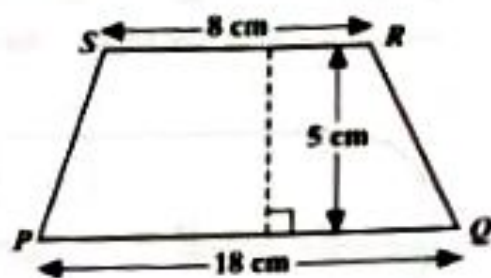

34. The area of the trapezium,  $PQRS$ , above is

- (A)  $45 \text{ cm}^2$   
 (B)  $65 \text{ cm}^2$   
 (C)  $90 \text{ cm}^2$   
 (D)  $130 \text{ cm}^2$

**Item 35** refers to the following diagram which shows a sector of a circle,  $AOB$ .  $AOB = 60^\circ$  and the radius  $OB$  is  $r$  units long.

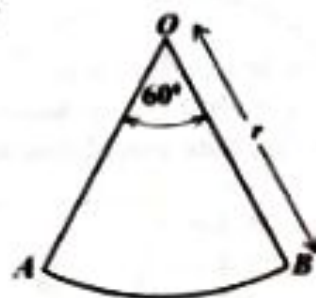

35. The area of  $AOB$  is

- (A)  $\frac{1}{6} \pi r^2$   
 (B)  $\frac{1}{6} \pi r$   
 (C)  $\frac{1}{3} \pi r^2$   
 (D)  $\frac{1}{3} \pi r$

GO ON TO THE NEXT PAGE

**Item 36** refers to the following diagram which shows a compound shape made up of a rectangle and two identical semi-circles, one on either of the short sides.

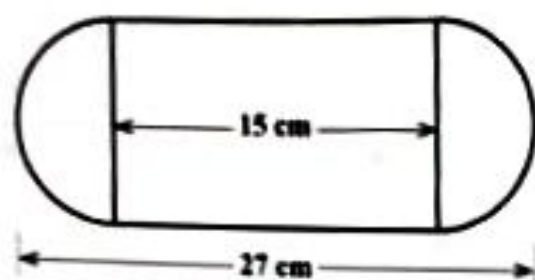

36. The perimeter of the figure above, in terms of  $\pi$ , is

- (A)  $6(5 + \pi)$
- (B)  $6(9 + \pi)$
- (C)  $6(5 + 2\pi)$
- (D)  $6(9 + 2\pi)$

37. The area of a rectangle is  $53.6 \text{ cm}^2$ . If the length is multiplied by 4 and the width is halved, the area would then be

- (A)  $26.8 \text{ cm}^2$
- (B)  $53.6 \text{ cm}^2$
- (C)  $107.2 \text{ cm}^2$
- (D)  $214.4 \text{ cm}^2$

**Item 38** refers to the following diagram, which consists of a triangle resting on a square of side 5 cm.

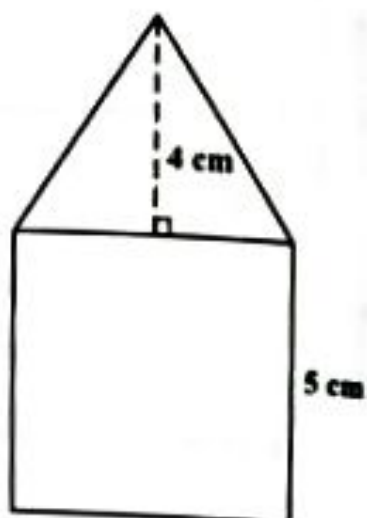

38. If the height of the triangle is 4 cm, what is the TOTAL area of the figure?

- (A)  $35 \text{ cm}^2$
- (B)  $45 \text{ cm}^2$
- (C)  $50 \text{ cm}^2$
- (D)  $100 \text{ cm}^2$

Items 39 and 40 refer to the following frequency distribution which shows the average mass, in kg, of a group of children in a school.

Mass (kg)	21-30	31-40	41-50	51-60	61-70
Frequency	28	40	12	34	18

39. The number of children who have a mass  $\leq 40$  kg is
- (A) 15  
(B) 40  
(C) 64  
(D) 68
40. The upper boundary of the median class is
- (A) 30.5  
(B) 40.5  
(C) 50.5  
(D) 60.5

41. Ms Clarke arranged the 15 test scores of her students in order of size and selected the 8th score for reporting purposes. Which of the following statistical measures did Ms Clarke obtain?

- (A) Mean  
(B) Mode  
(C) Range  
(D) Median

42. The pie chart below, drawn to scale, shows how a student used 12 hours in studying English (*E*), Mathematics (*M*), French (*F*) and Geography (*G*).

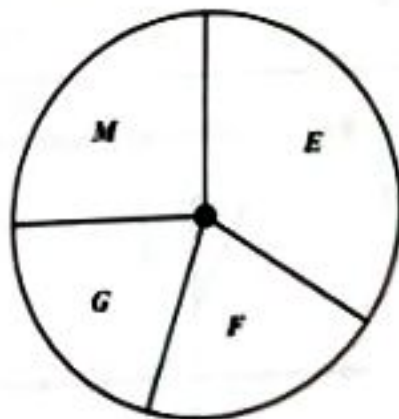

The amount of time spent studying Mathematics is APPROXIMATELY

- (A) 1 hour  
(B) 2 hours  
(C) 3 hours  
(D) 4 hours
43. If the mean of the FOUR numbers 4, 8,  $x$  and 12 is 10, then  $x$  is
- (A) 4  
(B) 10  
(C) 12  
(D) 16

GO ON TO THE NEXT PAGE



Item 44 refers to the following table which shows the results of a survey of 100 persons, from 2 major ethnic groups, *P* and *R*. Respondents were interviewed about their attitude towards Mathematics.

Attitude Towards Mathematics	Ethnicity		Total
	<i>P</i>	<i>R</i>	
Positive	25	12	37
Neutral	11	9	20
Negative	24	19	43
Total	60	40	100

44. A respondent is selected at random. What is the probability that he has a positive attitude towards Mathematics?
- (A) 0.20  
(B) 0.37  
(C) 0.43  
(D) 0.60

45. The point where a linear function crosses the horizontal axis is
- (A) the *x*-intercept  
(B) the *y*-intercept  
(C) always positive  
(D) always negative
46. The equation of the straight line which passes through the point (0, 5) and has a gradient of 4 is
- (A)  $y = 4x$   
(B)  $y = 5x$   
(C)  $y = 4x + 5$   
(D)  $y = 5x + 4$

47. Which of the following graphs represents a linear function?

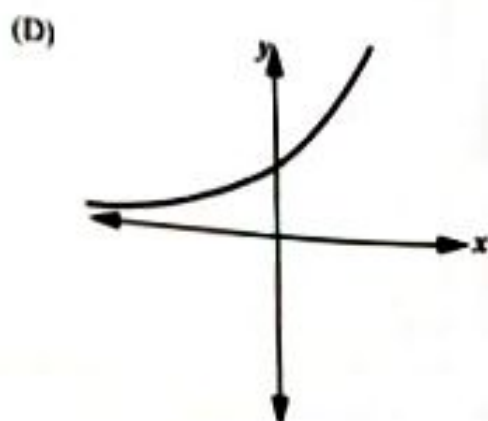
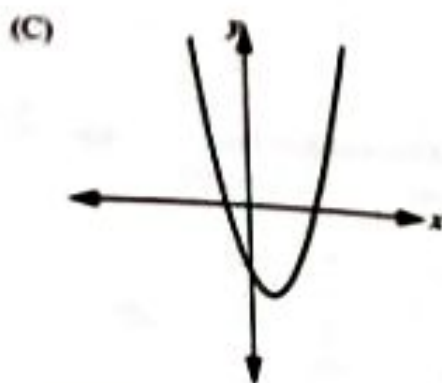
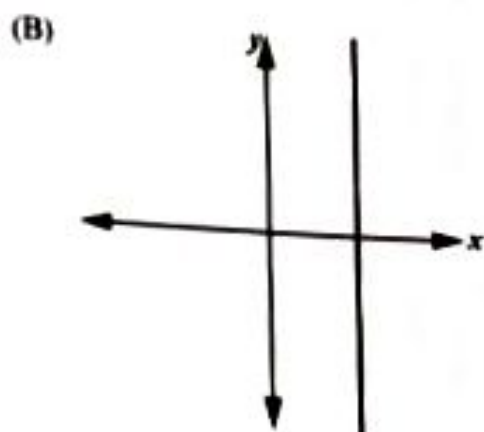

Item 48 refers to the following graph of a quadratic function.

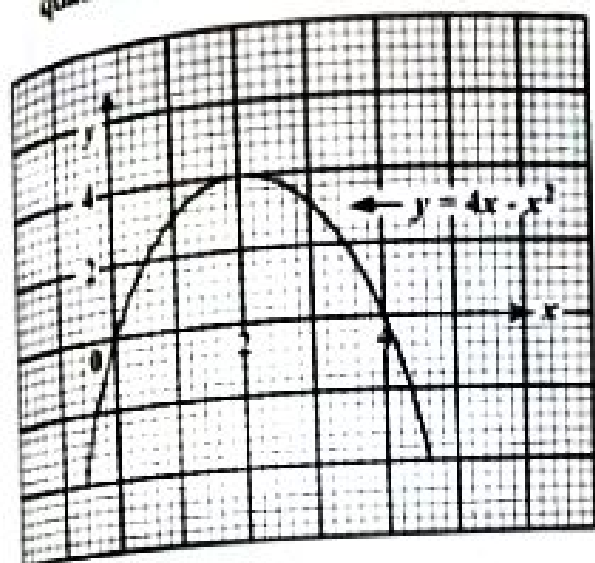

48. The coordinates of the maximum point of the function  $y = 4x - x^2$  are

- (A) (2, 4)
- (B) (0, 4)
- (C) (4, 2)
- (D) (4, 4)

49. A line  $L$  is parallel to the line

$$3x - 7y - 9 = 0.$$

What is the gradient of the line  $L$ ?

- (A)  $-\frac{7}{3}$
- (B)  $-\frac{9}{7}$
- (C)  $\frac{3}{7}$
- (D)  $\frac{7}{3}$

50. If  $g(x) = \frac{7x-3}{5}$ , then  $g(-6) =$

- (A) -9
- (B)  $-\frac{39}{5}$
- (C)  $\frac{39}{5}$
- (D) 9

51. The range of  $f: x \rightarrow x^2$  for the domain  $\{-2, -1, 0, 1, 2\}$  is

- (A)  $\{8, 1, 0, 1, 8\}$
- (B)  $\{6, 3, 0, 3, 6\}$
- (C)  $\{-6, -3, 0, 3, 6\}$
- (D)  $\{-8, -1, 0, 1, 8\}$

52. Which of the following pairs of lines is perpendicular?

- (A)  $2y = -3x - 8$   
 $3x - 2y = -8$
- (B)  $y = 2x + 1$   
 $y = 2x - 6$
- (C)  $y = -4x + 10$   
 $4y = x + 1$
- (D)  $x - 2y = -1$   
 $3x + 5y = 8$

53. If the sum of the interior angles of a polygon is 4 right angles, then the polygon is a

- (A) triangle
- (B) hexagon
- (C) pentagon
- (D) quadrilateral

Item 54 refers to the following diagram of a transformation.

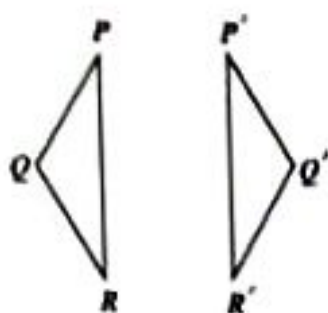

54. What transformation maps  $PQR$  onto  $P'Q'R'$ ?
- (A) Rotation  
 (B) Reflection  
 (C) Translation  
 (D) Enlargement

Item 55 refers to the following diagram of an isosceles triangle.



55. In the triangle, the value of  $x$  is
- (A)  $30^\circ$   
 (B)  $60^\circ$   
 (C)  $120^\circ$   
 (D)  $150^\circ$

Item 56 refers to the following pair of similar triangles.

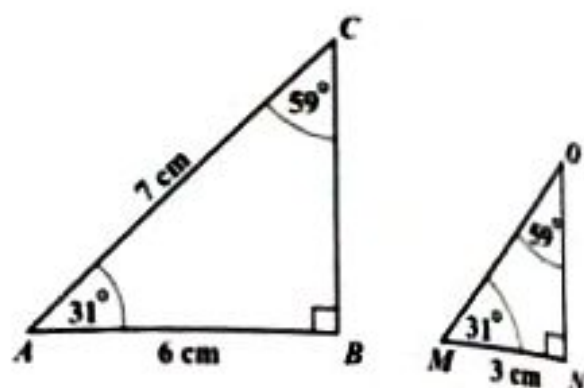

56. The length of  $MO$ , in cm, is
- (A) 2.5  
 (B) 3.0  
 (C) 3.5  
 (D) 7.0
57. The image of a point  $P(1, 2)$  under a translation is  $P'(-5, -4)$ . What is the translation vector?
- (A)  $\begin{bmatrix} -6 \\ -6 \end{bmatrix}$   
 (B)  $\begin{bmatrix} -4 \\ -2 \end{bmatrix}$   
 (C)  $\begin{bmatrix} 4 \\ 2 \end{bmatrix}$   
 (D)  $\begin{bmatrix} 6 \\ 6 \end{bmatrix}$
58. A plane is flying in a direction of  $045^\circ$  and changes course in a clockwise direction to  $135^\circ$ . The angle through which the plane turns is
- (A)  $45^\circ$   
 (B)  $90^\circ$   
 (C)  $135^\circ$   
 (D)  $270^\circ$

**Item 59** refers to the following diagram of a building.

A surveyor sets up his instruments 12 metres from the foot of the building and records the angle of elevation of the top of the building.

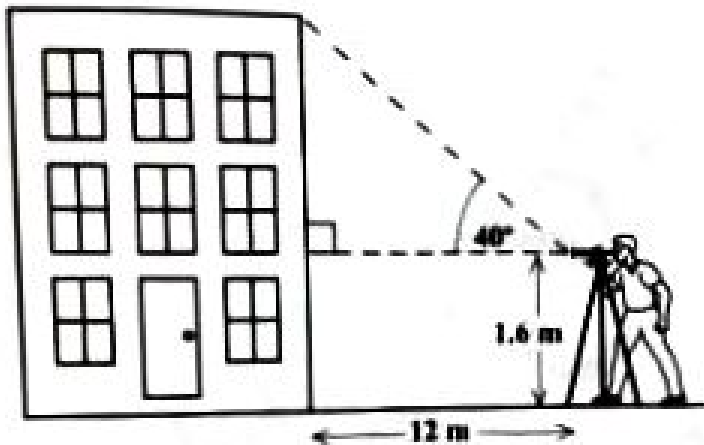

**59.** An estimate of the height of the building can be obtained by calculating

- (A)  $1.6 + 12 \cos 40^\circ$
- (B)  $1.6 + 12 \tan 40^\circ$
- (C)  $(12 \tan 40^\circ) - 1.6$
- (D)  $(12 \sin 40^\circ) - 1.6$

**Item 60** refers to the following diagram.

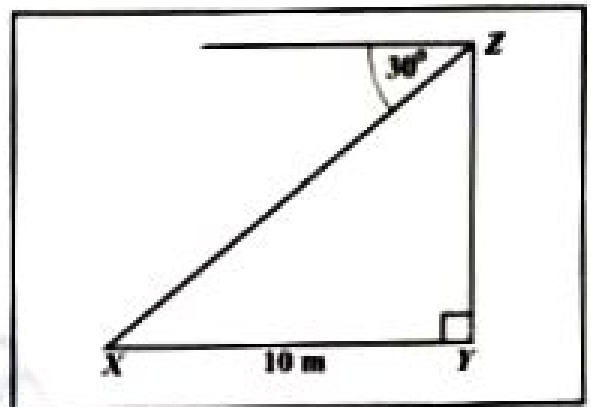

**60.** The diagram above shows that the angle of depression of a point  $X$  from  $Z$  is  $30^\circ$ . If  $X$  is 10 metres from  $Y$ , the height of  $YZ$ , in metres, is

- (A)  $10 \tan 30^\circ$
- (B)  $10 \sin 30^\circ$
- (C)  $10 \cos 30^\circ$
- (D)  $10 \cos 60^\circ$



**CANDIDATE – PLEASE NOTE!**  
 PRINT your name on the line below and return this booklet with your answer sheet. Failure to do so may result in disqualification.

**FORM TP 2023019**

TEST CODE **01234010**

JANUARY 2023

**CARIBBEAN EXAMINATIONS COUNCIL  
 CARIBBEAN SECONDARY EDUCATION CERTIFICATE®  
 EXAMINATION**

**MATHEMATICS**

**Paper 01 – General Proficiency**

*1 hour 30 minutes*

**27 JANUARY 2023 (a.m.)**

**READ THE FOLLOWING INSTRUCTIONS CAREFULLY.**

1. This test consists of 60 items. You will have 1 hour and 30 minutes to answer them.
2. In addition to this test booklet, you should have an answer sheet.
3. **A list of formulae is provided on page 2 of this booklet.**
4. Each item in this test has four suggested answers lettered (A), (B), (C), (D). Read each item you are about to answer and decide which choice is best.
5. On your answer sheet, find the number which corresponds to your item and shade the space having the same letter as the answer you have chosen. Look at the sample item below.

Sample Item

$2a + 6a =$

- (A)  $8a$
- (B)  $8a^2$
- (C)  $12a$
- (D)  $12a^2$

Sample Answer



The best answer to this item is “ $8a$ ”, so (A) has been shaded.

6. If you want to change your answer, erase it completely before you fill in your new choice.
7. When you are told to begin, turn the page and work as quickly and as carefully as you can. If you cannot answer an item, go on to the next one. You may return to that item later.
8. You may do any rough work in this booklet.
9. Calculators and mathematical tables are NOT allowed for this paper.
10. **ALL diagrams in this booklet are NOT drawn to scale, unless otherwise stated.**

**DO NOT TURN THIS PAGE UNTIL YOU ARE TOLD TO DO SO.**



**LIST OF FORMULAE**

Volume of a prism  $V = Ah$  where  $A$  is the area of the cross-section and  $h$  is the perpendicular length.

Volume of a cylinder  $V = \pi r^2 h$  where  $r$  is the radius of the base and  $h$  is the perpendicular height.

Volume of a right pyramid  $V = \frac{1}{3} Ah$  where  $A$  is the area of the base and  $h$  is the perpendicular height.

Circumference  $C = 2\pi r$  where  $r$  is the radius of the circle.

Arc length  $S = \frac{\theta}{360} \times 2\pi r$  where  $\theta$  is the angle subtended by the arc, measured in degrees.

Area of a circle  $A = \pi r^2$  where  $r$  is the radius of the circle.

Area of a sector  $A = \frac{\theta}{360} \times \pi r^2$  where  $\theta$  is the angle of the sector, measured in degrees.

Area of a trapezium  $A = \frac{1}{2} (a + b) h$  where  $a$  and  $b$  are the lengths of the parallel sides and  $h$  is the perpendicular distance between the parallel sides.

Roots of quadratic equations If  $ax^2 + bx + c = 0$ ,

$$\text{then } x = \frac{-b \pm \sqrt{b^2 - 4ac}}{2a}$$

Trigonometric ratios  $\sin \theta = \frac{\text{length of opposite side}}{\text{length of hypotenuse}}$

$$\cos \theta = \frac{\text{length of adjacent side}}{\text{length of hypotenuse}}$$

$$\tan \theta = \frac{\text{length of opposite side}}{\text{length of adjacent side}}$$

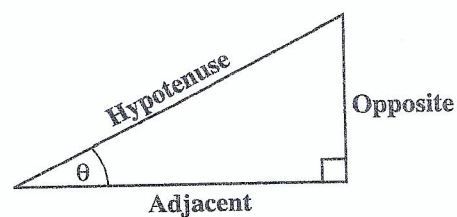

Area of a triangle Area of  $\Delta = \frac{1}{2} bh$  where  $b$  is the length of the base and  $h$  is the perpendicular height.

$$\text{Area of } \Delta ABC = \frac{1}{2} ab \sin C$$

$$\text{Area of } \Delta ABC = \sqrt{s(s-a)(s-b)(s-c)}$$

$$\text{where } s = \frac{a+b+c}{2}$$

Sine rule

$$\frac{a}{\sin A} = \frac{b}{\sin B} = \frac{c}{\sin C}$$

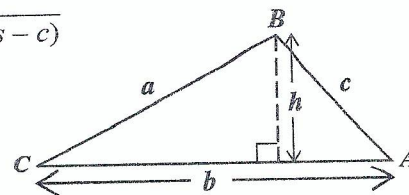

Cosine rule

$$a^2 = b^2 + c^2 - 2bc \cos A$$

1. What is the value of the digit 2 in the number 48.621?
- (A)  $\frac{2}{100}$   
(B)  $\frac{2}{10}$   
(C) 2  
(D) 200

2. What percentage of 50 is 10?
- (A) 5%  
(B) 20%  
(C) 32%  
(D) 150%

3. In standard notation, 0.02086 is written as
- (A)  $2.0806 \times 10^2$   
(B)  $20.806 \times 10^1$   
(C)  $2.0806 \times 10^{-2}$   
(D)  $0.20806 \times 10^3$

4. In a school, the ratio of the number of pupils to the number of teachers is 20:1. If the number of pupils is 840, how many teachers are there?
- (A) 40  
(B) 42  
(C) 820  
(D) 840

5. A bag of apples can be shared equally among either 6, 10 or 15 children. The MINIMUM number of apples that is likely to be in the bag is
- (A) 30  
(B) 31  
(C) 60  
(D) 90

6. If  $4.3 \times 0.37 = 1.591$ , then  $43 \times 0.37$  is
- (A) 1.591  
(B) 15.91  
(C) 159.1  
(D) 1 591.0

7. Which of the following sets is defined by  $\{x \in Z : -2 \leq x \leq 4\}$ ?
- (A)  $\{1, 2, 3, 4\}$   
(B)  $\{0, 1, 2, 3, 4\}$   
(C)  $\{-1, 0, 1, 2, 3\}$   
(D)  $\{-2, -1, 0, 1, 2, 3, 4\}$

Item 8 refers to the following Venn diagram which shows 2 intersecting sets,  $P$  and  $Q$ . In the Venn diagram,  $n(P) = 5$ ,  $n(Q) = 9$  and  $n(P \cup Q) = 10$ .

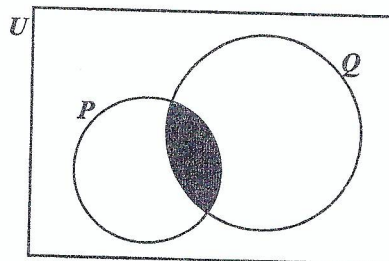

8. The number of elements in the shaded region of the Venn diagram is
- (A) 1  
(B) 4  
(C) 5  
(D) 9

9. Which of the following pairs of sets is an example of disjoint sets?

- (A)  $E = \{\text{even numbers}\}$  and  $F = \{\text{odd numbers}\}$
- (B)  $P = \{\text{multiples of 2}\}$  and  $Q = \{\text{multiples of 3}\}$
- (C)  $X = \{\text{whole numbers}\}$  and  $Y = \{\text{rational numbers}\}$
- (D)  $G = \{\text{multiples of five}\}$  and  $H = \{\text{multiples of ten}\}$

10. All students in a class play Scrabble or Checkers or both. If 36% of the students play Scrabble only and 16% of the students play both Scrabble and Checkers, what percentage of students play Checkers but NOT Scrabble?

- (A) 12
- (B) 48
- (C) 52
- (D) 64

Item 11 refers to the following Venn diagram which shows 2 intersecting sets. The number of students in each set is indicated.

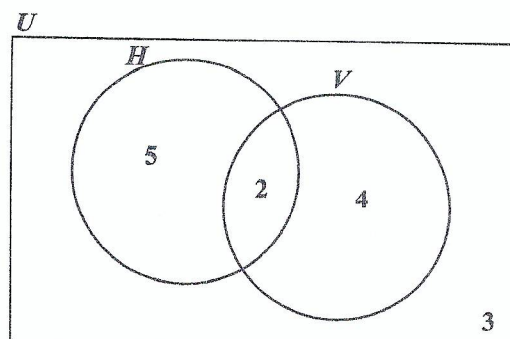

11. In the Venn diagram

- $U = \{\text{students who play games}\}$
- $H = \{\text{students who play hockey}\}$
- $V = \{\text{students who play volleyball}\}$

How many students play EITHER hockey OR volleyball but not both?

- (A) 6
- (B) 7
- (C) 9
- (D) 11

12. The set of two-digit positive integers that are divisible by 7 is an example of

- (A) an improper set
- (B) an infinite set
- (C) an empty set
- (D) a finite set

13. For every \$100 sales or part thereof, a salesman is paid \$10.00 as commission. If his sales for a particular month were \$1 020.00, how much commission was he paid?

- (A) \$ 10.20
- (B) \$ 20.20
- (C) \$102.00
- (D) \$110.00

14. The simple interest on \$600 for  $t$  years at 5% per annum is \$120. The value of  $t$  is
- (A)  $\$ \frac{600 \times 5}{100 \times 120}$
- (B)  $\$ \frac{100 \times 120}{600 \times 5}$
- (C)  $\$ \frac{100 \times 5 \times 120}{600}$
- (D)  $\$ \frac{600 \times 120 \times 5}{100}$
15. At a bank, EC\$2.60 is equivalent to US\$1.00. For every US\$1.00 exchanged, EC\$0.10 is deducted as an exchange tax. How many EC dollars will Leon receive if he exchanges US\$1 000.00?
- (A) \$ 900.90
- (B) \$2 360.34
- (C) \$2 500.00
- (D) \$2 600.00
16. A calculator which is marked at \$120 is sold for cash at a 30% discount. How much change would Susan receive if she pays for the calculator with a \$100 bill?
- (A) \$16
- (B) \$20
- (C) \$28
- (D) \$36
17. A man pays 60 cents for every 200 m<sup>3</sup> of gas used, plus a fixed charge. If he pays \$178.75 when he uses 55 000 m<sup>3</sup> of gas, how much is the fixed charge?
- (A) \$ 13.75
- (B) \$ 14.35
- (C) \$151.25
- (D) \$165.00
18. A plot of land presently valued at \$12 000 appreciates in value at the rate of 2.5% per annum. What will be the value of the plot of land one year later?
- (A) \$10 700
- (B) \$11 700
- (C) \$11 970
- (D) \$12 300
19. A loan of \$8 000 was paid back in 2 years in monthly payments of \$400. The interest on the loan, as a percentage, was
- (A) 5%
- (B)  $8\frac{1}{3}\%$
- (C)  $16\frac{2}{3}\%$
- (D) 20%
20. An article bought for \$125 was sold for \$175. The profit as a percentage of the cost price was
- (A) 28.6%
- (B) 40%
- (C) 50%
- (D) 71.4%

21. The product of a number,  $\frac{2p}{3}$  and its reciprocal may be written as

- (A)  $\frac{2p}{3} \times \frac{3}{p}$   
(B)  $\frac{2p}{3} \times -\frac{3p}{2}$   
(C)  $\frac{2p}{3} \times \frac{3}{2p}$   
(D)  $\frac{2p}{3} \times -\frac{3}{2p}$

Item 22 refers to the following diagram of a rectangle.

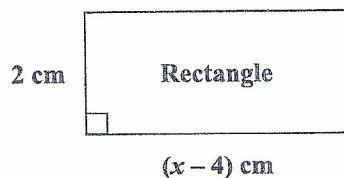

22. The area of the rectangle, in  $\text{cm}^2$ , is  $x^2$ . The equation that may be used to find the value of  $x$  is

- (A)  $x^2 = 2(x - 4)$   
(B)  $x^2 = (x - 2)(x - 4)$   
(C)  $x^2 = (x - 4)(x + 2)$   
(D)  $x^2 = 2(x - 4)(x - 2)$

23. Althea normally saves  $\$x$  each month, but in June, she saved  $\$4$  more than twice her usual amount. In June she saved

- (A)  $\$ 4x$   
(B)  $\$ 6x$   
(C)  $\$ 2(x + 4)$   
(D)  $\$ (2x + 4)$

24. If  $3 + \frac{x}{2} = 1$ , the value of  $x$  is

- (A)  $-11$   
(B)  $-4$   
(C)  $\frac{1}{4}$   
(D)  $\frac{1}{2}$

25.  $5^{n+1} \times 5^{n+2}$  is the same as

- (A)  $5^{2n}$   
(B)  $5^{2n+3}$   
(C)  $5^{3(2n)}$   
(D)  $2 \times 5^{2n}$

26. If  $a * b = a^2 + b^2$ , then the value of  $(3 * 4) * 2$  is

- (A)  $25^2 + 2^2$   
(B)  $12^2 + 2^2$   
(C)  $(3 + 4 + 2)^2$   
(D)  $(3^2 + 4^2) + 2^2$

27. If  $|A| = 0$ , then  $A$  is

- (A) an inverse matrix  
(B) a singular matrix  
(C) an identity matrix  
(D) a non-singular matrix

28. If  $A = \begin{pmatrix} 1 & 2 & 5 & 4 \\ 6 & 1 & 3 & 7 \\ -2 & 3 & 2 & 9 \end{pmatrix}$ , then the order of  $A$  is

- (A)  $2 \times 3$
- (B)  $3 \times 2$
- (C)  $3 \times 4$
- (D)  $4 \times 3$

29. If the vectors  $\mathbf{p}$  and  $\mathbf{q}$  are  $\begin{pmatrix} 3 \\ 2 \end{pmatrix}$  and  $\begin{pmatrix} -1 \\ 4 \end{pmatrix}$  respectively, then  $-\mathbf{p} - 2\mathbf{q}$  is

- (A)  $\begin{pmatrix} -5 \\ 10 \end{pmatrix}$
- (B)  $\begin{pmatrix} 5 \\ -6 \end{pmatrix}$
- (C)  $\begin{pmatrix} 2 \\ -6 \end{pmatrix}$
- (D)  $\begin{pmatrix} -1 \\ -10 \end{pmatrix}$

Item 30 refers to the following diagram of triangle  $OLM$ , in which  $R$  is the midpoint of  $\overrightarrow{OL}$ . Further,  $\overrightarrow{OR} = 3\mathbf{a} - 2\mathbf{b}$  and  $\overrightarrow{OM} = 2\mathbf{a} + 3\mathbf{b}$ .

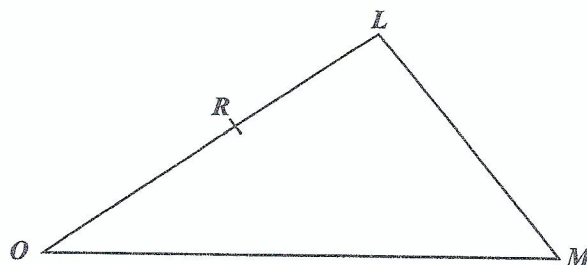

30.  $\overrightarrow{LM}$  expressed in terms of  $\mathbf{a}$  and  $\mathbf{b}$  is

- (A)  $5\mathbf{b} - \mathbf{a}$
- (B)  $7\mathbf{b} - 4\mathbf{a}$
- (C)  $4\mathbf{a} + 7\mathbf{b}$
- (D)  $2(2\mathbf{a} + 3\mathbf{b})$

Item 31 refers to the following diagram which shows a cylinder with diameter 6 cm and height 20 cm.

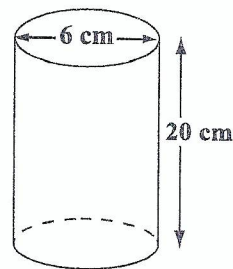

31. The volume of the cylinder, in  $\text{cm}^3$ , and in terms of  $\pi$ , is

- (A) 60
- (B) 120
- (C) 180
- (D) 720

Item 32 refers to the following diagram which shows a circle, centred at  $O$ , and with a sector and the major and minor arcs indicated.

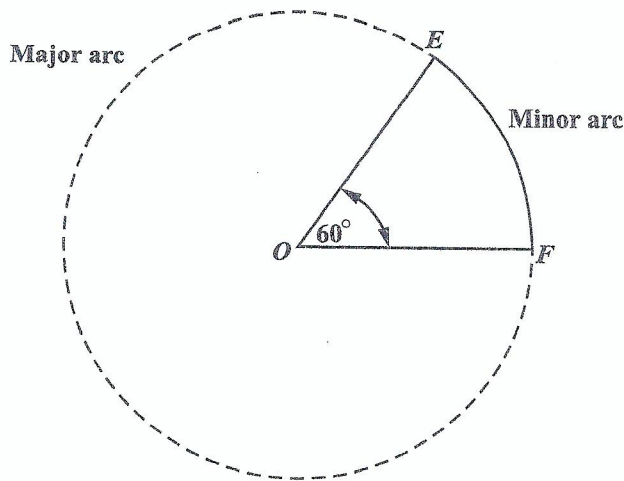

32. If the area of the minor sector,  $EOF$ , is  $103 \text{ cm}^2$ , then the area of the circle, in  $\text{cm}^2$ , is
- (A) 206  
(B) 412  
(C) 515  
(D) 618
33. If it took a speedboat 9 hours to travel a distance of 1 080 km, what was its average speed, in  $\text{kmh}^{-1}$ ?
- (A) 12  
(B) 102  
(C) 120  
(D) 1 200
34. The lengths of the sides of a triangle are  $x$ ,  $2x$  and  $2x$  centimetres. If the perimeter is 20 centimetres, what is the value of  $x$ ?
- (A) 4  
(B) 5  
(C) 8  
(D) 10
35. Fifty guests had 2 glasses of champagne each. Each glass held 150 millilitres. How many litres of champagne were used?
- (A) 0.15  
(B) 1.5  
(C) 15  
(D) 150
36. A square has the same perimeter as a rectangle with length 15 centimetres and width 11 centimetres. What is the area of the square, in  $\text{cm}^2$ ?
- (A) 26  
(B) 52  
(C) 165  
(D) 169
37. The circumference of a circle is 154 cm.
- Given that  $\pi = \frac{22}{7}$ , the radius of the circle, in centimetres, is
- (A) 7  
(B) 24.5  
(C) 49  
(D) 54
38. The distance around a lake is 8 km. On a map, this distance around the lake is represented by a length of 2 cm. The scale on the map is
- (A) 1 : 40  
(B) 1 : 2 000  
(C) 1 : 200 000  
(D) 1 : 400 000

Items 39 and 40 refer to the following table which shows the number of books that 58 students bought at a sale.

No. of Books Bought	3	4	5	6	7	8
No. of Students	9	9	13	11	9	7

39. The mode of the number of books bought is
- (A) 5  
(B) 7  
(C) 9  
(D) 13
40. The median number of books the students bought at the sale is
- (A) 4  
(B) 5  
(C) 6  
(D) 13

Item 41 refers to the following pie chart which shows the popular games played by a group of students.

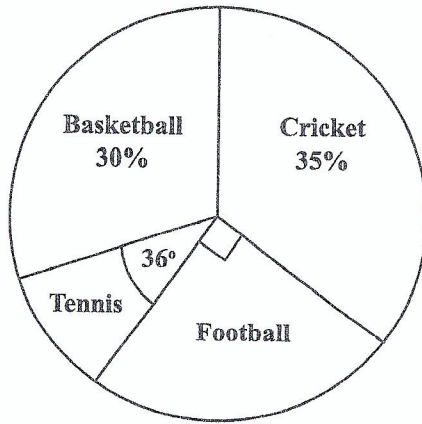

41. If 180 students played football, how many students are in the group?
- (A) 300  
(B) 360  
(C) 720  
(D) 900

Item 42 refers to the following chart which shows the amount of fish bought, in kg, by the first 60 customers at a fish market.

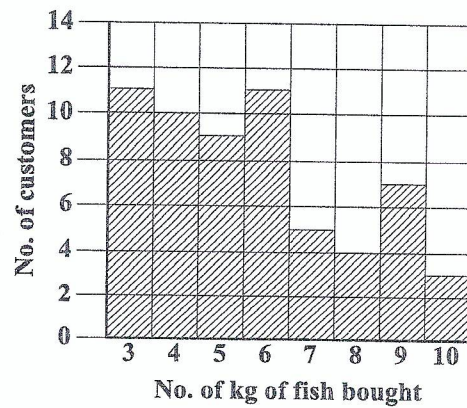

42. How many customers bought at LEAST 6 kg of fish?
- (A) 18  
(B) 19  
(C) 30  
(D) 34

Item 43 refers to the following diagram which shows the cumulative frequency curve of the heights of 20 plants.

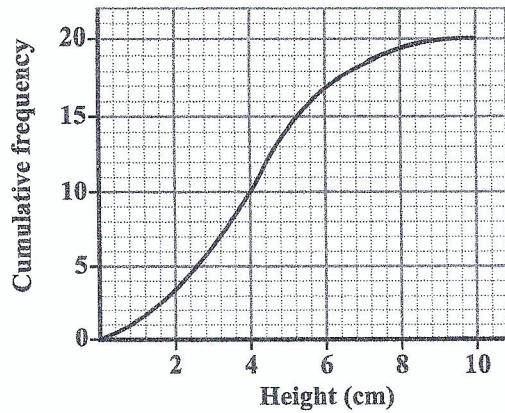

43. The interquartile range of the set of measurements is
- (A) 2.2 cm
  - (B) 2.6 cm
  - (C) 5.0 cm
  - (D) 5.2 cm

Item 44 refers to the following table which shows the results of a survey of 100 persons from 2 major ethnic groups, *P* and *R*. Respondents were interviewed about their attitude towards Mathematics.

Attitude Towards Mathematics	Ethnicity		Total
	<i>P</i>	<i>R</i>	
Positive	25	12	37
Neutral	11	9	20
Negative	24	19	43
Total	60	40	100

44. A respondent from ethnic group *P* is selected at random. What is the probability that he has a negative attitude towards Mathematics?
- (A)  $\frac{11}{100}$
  - (B)  $\frac{6}{25}$
  - (C)  $\frac{1}{4}$
  - (D)  $\frac{2}{5}$
45. The point where a linear function crosses the horizontal axis is
- (A) the *y*-intercept
  - (B) the *x*-intercept
  - (C) always positive
  - (D) always negative

Item 46 refers to the following mapping diagram.

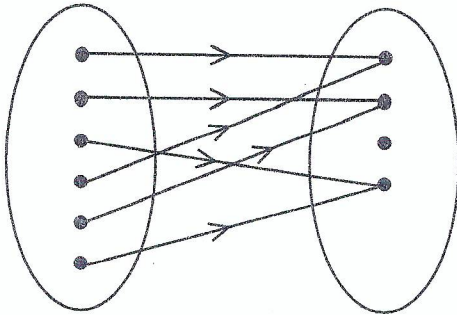

46. The relationship that BEST describes the mapping in the diagram is

- (A) one-to-one
- (B) one-to-many
- (C) many-to-one
- (D) many-to-many

47. If  $h(x) = \frac{3x-2}{5}$ , then  $h(-6) =$

- (A)  $-4$
- (B)  $-\frac{16}{5}$
- (C)  $\frac{16}{5}$
- (D)  $4$

Items 48 and 49 refer to the following graph of a quadratic function.

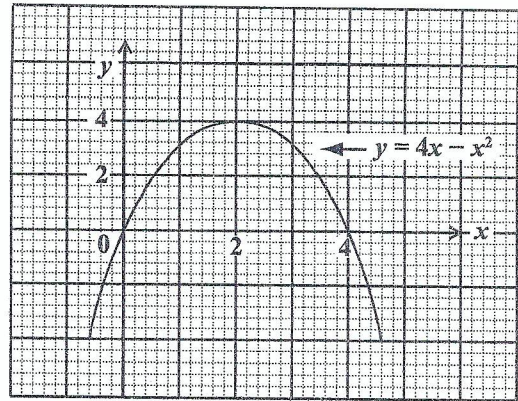

48. The maximum point of  $y = 4x - x^2$  is

- (A)  $(0, 0)$
- (B)  $(0, 4)$
- (C)  $(4, 2)$
- (D)  $(2, 4)$

49. The values of  $x$  at the points where  $y = 4x - x^2$  intersects  $y = 0$  are

- (A)  $x = 0$  and  $x = 4$
- (B)  $x = 0$  and  $x = 2$
- (C)  $x = 2$  and  $x = 4$
- (D)  $x = 0$  and  $x = -4$

50. Which of the following equations represents a straight line?

- (A)  $xy = 4$
- (B)  $y + 4 = x^2$
- (C)  $y + 3 = 2x$
- (D)  $y = x^2 + 2x - 5$

51. Which of the following sets is represented by the function  $f: x \rightarrow x^2 + 3$  where  $x \in \{0, 1, 2, 3\}$ ?

- (A)  $\{(0, 3), (1, 1), (2, 4), (3, 9)\}$
- (B)  $\{(0, 3), (1, 4), (2, 5), (3, 6)\}$
- (C)  $\{(0, 3), (1, 5), (2, 7), (3, 9)\}$
- (D)  $\{(0, 3), (1, 4), (2, 7), (3, 12)\}$

52. A line  $L$  is parallel to the line  $2x - 5y - 8 = 0$ .

What is the gradient of the line  $L$ ?

- (A)  $-\frac{5}{2}$
- (B)  $-\frac{2}{5}$
- (C)  $\frac{2}{5}$
- (D)  $2$

Item 53 refers to the following diagram of a circle.

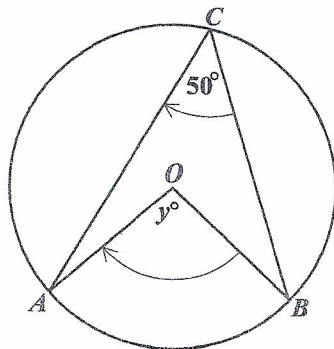

53. If  $O$  is the centre of the circle, then  $y^\circ$  is

- (A)  $25^\circ$
- (B)  $80^\circ$
- (C)  $90^\circ$
- (D)  $100^\circ$

Item 54 refers to the following diagram.

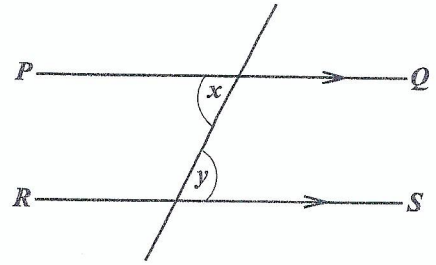

54. In the diagram,  $PQ$  and  $RS$  are parallel. Which of the following BEST describes the relation between  $x$  and  $y$ ?

- (A)  $x = y$
- (B)  $x < y$
- (C)  $x + y = 90^\circ$
- (D)  $x + y = 180^\circ$

Item 55 refers to the following diagram which shows rectangle  $WXYZ$  and its image  $W'X'Y'Z'$  and  $W''X''Y''Z''$  after it undergoes a composite/double transformation.

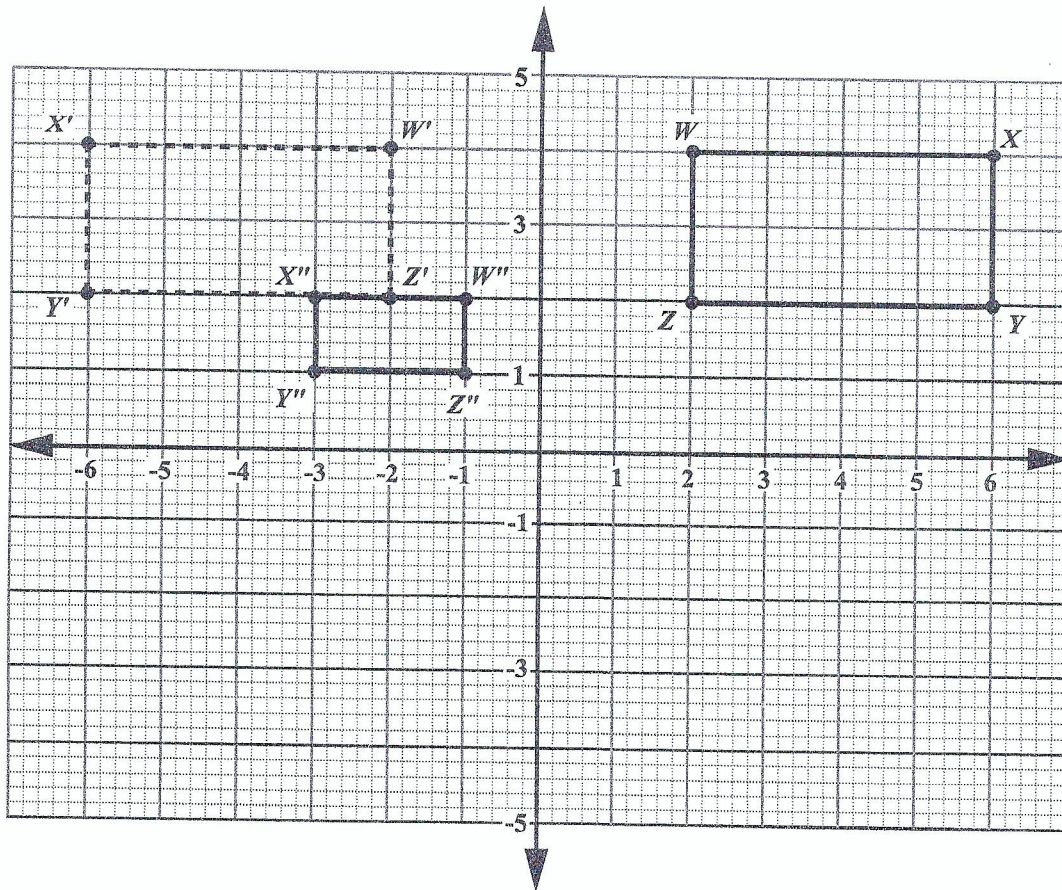

55. What sequence of transformations will map rectangle  $WXYZ$  onto its image, rectangle  $W''X''Y''Z''$ ?
- (A) A translation of 8 units to the left, followed by an enlargement, centred at the origin with scale factor of  $\frac{1}{2}$
  - (B) A reflection in the  $y$ -axis, followed by an enlargement, centred at the origin with scale factor of  $\frac{1}{2}$
  - (C) A counterclockwise rotation of  $90^\circ$  about the origin, followed by an enlargement, centred at the origin with scale factor of  $\frac{1}{2}$
  - (D) An enlargement, centred at the origin with scale factor of  $\frac{1}{2}$ , followed by a counterclockwise rotation of  $90^\circ$  about the origin

56. In each of the following diagrams,  $A'$  is the image of  $A$ . Which of the diagrams shows a reflection in the  $x$ -axis?

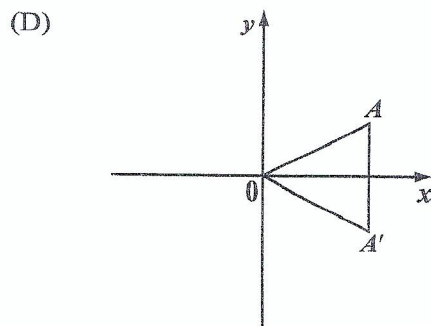
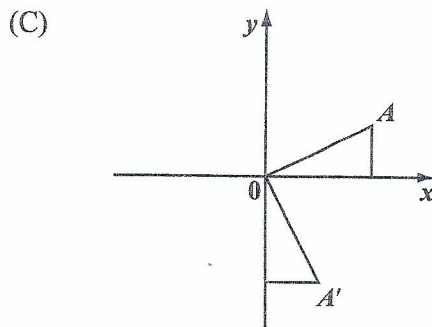
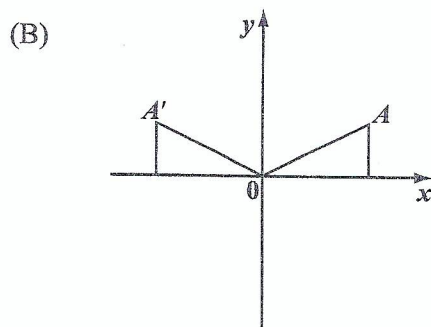
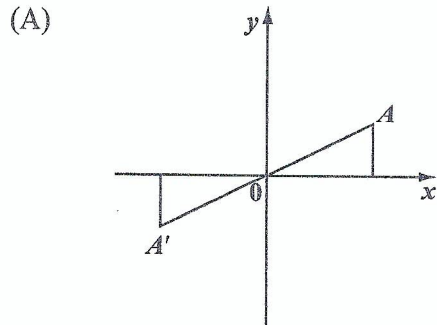

57. In triangle  $ABC$ , angle  $A = x^\circ$  and angle  $B = 2x^\circ$ . What is the size of angle  $C$ ?

- (A)  $(180 - 3x)^\circ$   
 (B)  $60^\circ$   
 (C)  $30^\circ$   
 (D)  $\left[\frac{180}{3x}\right]^\circ$

Item 58 refers to the following diagram which shows the angle of depression of a point,  $X$ , from  $Z$ .

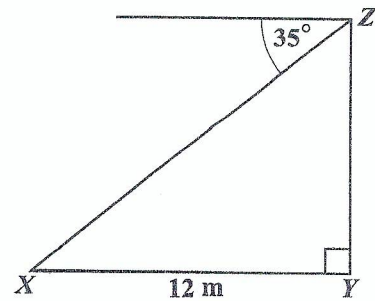

58. The angle of depression of the point  $X$  from  $Z$  is  $35^\circ$ . If  $X$  is 12 metres from  $Y$ , then the height  $YZ$ , in metres, is

- (A)  $12 \cos 35^\circ$   
 (B)  $12 \cos 55^\circ$   
 (C)  $12 \sin 55^\circ$   
 (D)  $12 \tan 35^\circ$

Item 59 refers to the following diagram of a right-angled triangle,  $ABC$ .

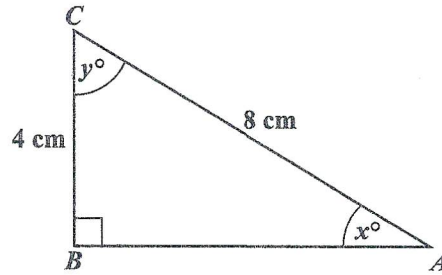

59. In the right-angled triangle above, which trigonometric ratio is equal to  $\frac{4}{8}$ ?
- (A)  $\sin x$
  - (B)  $\tan y$
  - (C)  $\cos x$
  - (D)  $\tan x$

60. Under the translation  $\begin{bmatrix} -2 \\ 3 \end{bmatrix}$ , the image of  $(-5, 3)$  is
- (A)  $(0, -3)$
  - (B)  $(1, -2)$
  - (C)  $(-7, 6)$
  - (D)  $(3, 6)$

END OF TEST

IF YOU FINISH BEFORE TIME IS CALLED, CHECK YOUR WORK ON THIS TEST.